

# Final Project Report

## Woodacre – San Geronimo Flats Wastewater Recycling Study

---

*Prepared for:*

***Marin County Community Development Agency  
Environmental Health Services Division  
3501 Civic Center Drive, Room 236  
San Rafael, California 94903***

*By:*

***Questa Engineering Corporation  
1220 Brickyard Cove Road, Suite 206  
Point Richmond, California 94801***



***February 2019***

---

*All County publications are available in alternative formats (Braille, Large Print, or CD), upon request. Requests for accommodations may be made by calling (415) 473-4381 (Voice) 473-3232 (TDD/TTY) or by e-mail at [disabilityaccess@marincounty.org](mailto:disabilityaccess@marincounty.org). Copies of documents are available in alternative formats, upon request.*

# Final Project Report

## Woodacre San Geronimo Flats Wastewater Recycling Study Marin County, California

---

Prepared for:

**Marin County Community Development Agency  
Environmental Health Services Division**  
3501 Civic Center Drive, Room 236  
San Rafael, California 94903

Prepared by:

**Questa Engineering Corporation**  
1220 Brickyard Cove Road, Suite 206  
Point Richmond, California 94801  
Tel: 510.236.6114  
Fax: 510.236.2423  
www.questaec.com

Questa Project no. 1600073

February 2019

  
Norman N. Hantzsche P.E.

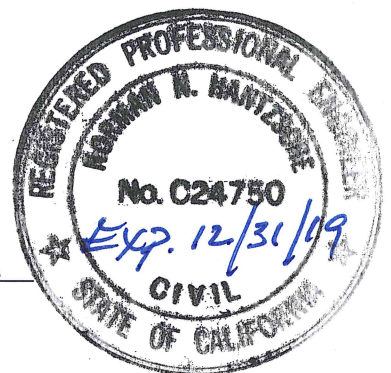

Funding for this project has been provided in full or in part through an agreement with the State Water Resources Control Board. The contents of this document do not necessarily reflect the views and policies of the State Water Resources Control Board, nor does mention of trade names or commercial products constitute endorsement or recommendation for use.

# TABLE OF CONTENTS

<b>EXECUTIVE SUMMARY .....</b>	<b>ES-1</b>
Background and Introduction .....	ES-1
Existing Wastewater Disposal Practices.....	ES-2
Service Area .....	ES-3
Estimated Wastewater Flows .....	ES-4
Project Alternatives .....	ES-4
Estimated Recycled Water Volumes .....	ES-8
Estimated Project Costs .....	ES-9
<b>SECTION 1: INTRODUCTION AND BACKGROUND .....</b>	<b>1</b>
<b>SECTION 2: STUDY AREA CONDITIONS.....</b>	<b>3</b>
Geographical Setting.....	3
Hydrology.....	3
Geology and Soils .....	4
Water Supply .....	6
Water Quality .....	7
<b>SECTION 3: EXISTING WASTEWATER TREATMENT AND DISPOSAL PRACTICES .....</b>	<b>10</b>
Overview .....	10
“Septic Matters Program” .....	11
Permit File Reviews .....	14
Onsite Field Reviews .....	16
Large-flow onsite Wastewater Systems.....	17
<b>SECTION 4: SERVICE AREA CHARACTERISTICS.....</b>	<b>19</b>
Service Area .....	19
Estimated Wastewater Flows .....	20
<b>SECTION 5: WASTE DISCHARGE AND RECYCLING REGULATORY REQUIREMENTS .....</b>	<b>25</b>
Onsite Wastewater treatment systems (OWTS) .....	25
Title 22 - Water Recycling Criteria.....	28
Waste Discharge Requirements (WDR).....	30
<b>SECTION 6: PROJECT ALTERNATIVES .....</b>	<b>32</b>
Introduction .....	32
Alternative 1 – No Project.....	32
Alternative 2 - Onsite System Upgrade and Management Program.....	34
Alternative 3 – Fire Road Community Leachfield (Woodacre Only) .....	41
Alternative 4 – Water Recycling System With Storage Ponds .....	46
Alternative 5 –Water Recycling System without ponds .....	58
<b>SECTION 7: COMPARATIVE ANALYSIS OF PROJECT ALTERNATIVES .....</b>	<b>71</b>
Regulatory Compliance .....	71
Environmental Impacts.....	72
Reliability.....	75
Water Conservation and recycling.....	78
Land AREA NEEDs .....	79
Costs.....	80

Comparative Summary and Ranking.....	82
<b>SECTION 8: RECOMMENDED FACILITIES PROJECT PLAN.....</b>	<b>86</b>
Water Recycling Facilities .....	86
Project Implementation Plan.....	97
Operational Plan .....	105
<b>SECTION 9: REFERENCES.....</b>	<b>113</b>

## APPENDICES

A	Onsite Wastewater Treatment Literature
B	Onsite System Upgrade Options and Cost Estimates
C	Fire Road Community Leachfield Information
D	Wastewater Collection Systems
E	Wastewater Treatment Literature
F	Water Balance Calculations and Reference Data
G	Clubhouse Parcel Irrigation and Soils Information
H	Recycled Water Project Cost Estimates
I	Climate Change Analysis
J	Institutional Alternatives Review
K	Woodacre Creek and San Geronimo Creek Microbial Source Tracking Results

## LIST OF FIGURES

Figure ES-1	Study Area
Figure ES-2	Project Alternatives
Figure ES-3	Recommend Project Alternatives
Figure 1-1	Location Map
Figure 2-1	Study Area
Figure 2-2	San Geronimo Creek Watershed
Figure 2-3	Key Water Supply Facilities (MMWD)
Figure 3-1	Typical Onsite Conditions – Railroad/Central Area
Figure 3-2	Typical Onsite Conditions – Creekside Area
Figure 3-3	Typical Onsite Conditions – Sloping Sites
Figure 3-4	Woodacre Septic System Permit and Field Reviews
Figure 3-5	San Geronimo Septic System Permit Reviews
Figure 3-6	“Large-Flow” Onsite Wastewater Systems
Figure 4-1	Service Area Options
Figure 4-2	Unit Wastewater Flow Comparisons
Figure 6-1	Project Alternatives
Figure 6-2	Alternative 3 – Fire Road Leachfield
Figure 6-3	Secondary Treatment Schematic
Figure 6-4	Alternative 4a
Figure 6-5	Water Recycling System Schematic – Alternative 4a
Figure 6-6	Wastewater Treatment Plant Location
Figure 6-7	Recycled Water Storage Pond #1 – Preliminary Layout
Figure 6-8	Alternatives 4b & 4c
Figure 6-9	Water Recycling Schematic – Alternatives 4b & 4c
Figure 6-10	Recycled Water Storage Pond #2 – Preliminary Layout

- Figure 6-11 Water Recycling Alternatives 5a, 5b & 5c
- Figure 6-12 Water Recycling System Schematic – Alternatives 5a, 5b & 5c
- Figure 8-1 Recommended Project Alternative 5c
- Figure 8-2 Recycled Water System Schematic
- Figure 8-3 Wastewater Collection Facilities - Woodacre
- Figure 8-4 Wastewater Collection Facilities – San Geronimo
- Figure 8-5 Wastewater Facilities on Clubhouse Parcel
- Figure 8-6 Tertiary Treatment System – Preliminary Layout

## LIST OF TABLES

Table ES-1. Estimated Annual Recycled Water Production – Alternative 4, With Ponds .....	ES-8
Table ES-2. Estimated Annual Recycled Water Production – Alternative 5, Without Ponds ..	ES-9
Table ES-3. Summary of Estimated Costs .....	ES-10
Table 2-1. Monthly Rainfall for Woodacre, California.....	4
Table 2-2. Tomales Bay TMDL Pathogen Limits .....	9
Table 3-1. Summary of Septic System Inspection Findings, Septic Matters Program* .....	13
Table 3-2. “Septic Matters” Inspection Results for Woodacre & San Geronimo* .....	14
Table 3-3. Septic System and Installation Permitting Summary .....	15
Table 3-4. Types of Onsite Wastewater Systems in Use .....	16
Table 4-1. Unit Flow Reference Data for Community Wastewater Facilities <sup>1</sup> .....	21
Table 4-2. Estimated Wastewater Flows, gpd .....	22
Table 6-1. Repair Criteria - Onsite Wastewater Management Program .....	35
Table 6-2. Onsite System Upgrade Assessment Needs Summary .....	37
Table 6-3. Estimated Individual Onsite System Upgrade Costs.....	38
Table 6-4. Estimated Capital Costs for Onsite Upgrade and Management Program .....	39
Table 6-5. Estimated Annual O&M Costs, Onsite Management Program.....	39
Table 6-6. Estimated Capital Cost - Fire Road Community Leachfield .....	45
Table 6-7. Estimated Annual O&M Costs – Fire Road Community Leachfield .....	46
Table 6-8. Water Balance Summary for Recycled Water Storage Pond #1, Alternative 4a .....	51
Table 6-9. Estimated Capital Costs – Alternative 4a.....	53
Table 6-10. Estimated Annual O&M Costs – Alternative 4a.....	54
Table 6-11. Recycled Water Storage Ponds #1 and #2.....	56
Table 6-12. Recycled Water Produced – Average Annual Volumes <sup>1</sup> .....	56
Table 6-13. Estimated Capital Costs - Alternatives 4b & 4c.....	57
Table 6-14. Estimated Annual O&M Cost – Alternatives 4b and 4c.....	58
Table 6-15. Estimated Capital Costs – Alternative 5a.....	66
Table 6-16. Estimated Annual O&M Costs – Alternative 5a.....	67
Table 6-17. Recycled Water Produced – Average Annual Volumes .....	69
Table 6-18. Estimated Capital Costs - Alternatives 5b & 5c.....	69
Table 6-19. Estimated Annual O&M Cost – Alternatives 5b & 5c .....	70
Table 7-1. Estimated Annual Energy Use for Project Alternatives .....	77
Table 7-2. Estimated Greenhouse Gas Emissions for Project Alternatives.....	78
Table 7-3. Recycled Water Produced – Average Annual Volumes .....	79
Table 7-4. Land Area Impact Comparison – Water Recycling Alternatives .....	80
Table 7-5. Project Alternatives Cost Comparison .....	81
Table 7-6. Estimated Costs for Recycled Water, 30-yr Basis .....	82
Table 7-7. Numerical Rating of Alternatives* .....	84
Table 8-1. Proposed Effluent Limits .....	88
Table 8-2. Capital Cost Summary .....	94

Table 8-3. Estimated Annual O&M Cost.....	95
Table 8-4. Water Recycling Treatment Plant Design and Reliability Features .....	96
Table 8-5. Summary of Horizontal Setback Requirements (feet).....	101
Table 8-6. Proposed Effluent Limits .....	102
Table 8-7. Management and Operation Requirements for Landscape Water Recycling.....	108
Table 8-8. Recommended Monitoring Schedule.....	110

## ACRONYMS AND ABBREVIATIONS

AMSL	above mean sea level
ABS	acrylonitrile butadiene
ave	average
BOD	biochemical oxygen demand
CCF	one hundred cubic feet
CSA	County Service Area
CSD	Community Services District
CWA	Federal Clean Water Act
CWD	County Water District
cy	cubic yard
DDW	Division of Drinking Water
ea	each
EHS	Environmental Health Services
EIR	Environmental Impact Report
EPA	U. S. Environmental Protection Agency
EQ	equalization
ESD	Equivalent Single-Family Dwelling
fm	force main
ft	feet
gal	gallon
gpd	gallons per day
gpm	gallons per minute
GHG	Greenhouse Gas
GW	groundwater
HDD	horizontal directional drilling
HDPE	high density polyethylene
hr	hour
I/I	infiltration and inflow
kW	kilowatt
kWhr	kilowatt-hour
LAFCO	Local Agency Formation Commission
lf	lineal feet
ls	Lump sum
l	liter
MCEHS	Marin County Environmental Health Services
MMWD	Marin Municipal Water District

MBR	Membrane Bioreactor
MBAS	Methylene Blue Active Substances
mg	milligram
ml	milliliter
MPI	minutes per inch
MRP	Monitoring and Reporting Program
MPN	most probable number
NCSS	National Cooperative Soil Survey
NTU	Nephelometric Turbidity Units
OWTS	Onsite Wastewater Treatment Systems
O&M	Operation and Maintenance
PD	pressure distribution
PLC	Programmable Logic Controller
PUD	Public Utility District
PVC	polyvinyl chloride
qty	quantity
RVSD	Ross Valley Sanitary District (RVSD)
RWQCB	Regional Water Quality Control Board
SAP	Sampling and Analysis Plan
sf	square-foot
STEG	Septic Tank Effluent Gravity
SRT	solids residence time
STEP	Septic Tank Effluent Pump
SSMP	Sewer System Management Plan
SWRCB	State Water Resources Control Board
TBWC	Tomales Bay Watershed Council
TDS	total dissolved solids
TKN	total kjeldahl nitrogen
TMDL	total maximum daily load
TSS	total suspended solids
typ	typical
UV	ultra-violet
WDR	Waste Discharge Requirements
ww	wastewater

# EXECUTIVE SUMMARY

## BACKGROUND AND INTRODUCTION

This report presents the results of a study regarding the feasibility of constructing a community sewer system and tertiary water recycling treatment facility for up to approximately 360 developed properties currently served by onsite wastewater systems (septic systems) in the San Geronimo Valley area of Marin County. The Study Area encompasses the low-lying and more densely developed portions of the unincorporated communities of Woodacre and San Geronimo (**Figure ES-1**).

Woodacre and San Geronimo are located in the San Geronimo Creek watershed, tributary to Lagunitas Creek which is listed as impaired for pathogens, nutrients, and sediment. The Tomales Bay Pathogen Total Maximum Daily Load (TMDL) of 2005 identifies lower San Geronimo Creek as the second greatest source of fecal coliforms entering Tomales Bay, after Walker Creek, and requires the County of Marin to take action to address failing septic systems.

Inspections of existing septic systems in the winters of 2004-05 and 2007-08 in Woodacre found a high percentage (77%) of homes had marginal or failing systems. Water quality monitoring in Woodacre Creek by the Tomales Bay Watershed Council (TBWC) during the same time period found generally high levels of total and fecal coliform, nitrates and ammonia, as well as methylene blue active substances (MBAS), a component of detergents. This led to their identification of Woodacre as a high priority for correction of failing septic systems, the formation of a local homeowner steering group (Woodacre Flats Wastewater Group), and eventually the initiation of a wastewater feasibility study for the “Woodacre Flats” area sponsored by the County of Marin with funding from the local community, the County, and the U.S. EPA.

The “Woodacre Flats Wastewater Feasibility Study” was completed by Questa Engineering Corporation (Questa) in July 2011, identifying and evaluating wastewater improvement alternatives for approximately 150 parcels in the most problematic areas of the community affected by high groundwater, drainage, clayey soils, small parcel size and age of systems. The study identified two promising options: (1) a local community leachfield option with limited capacity for properties in Woodacre; and (2) a wastewater recycling alternative centered around the San Geronimo Golf Course that could potentially support a larger number of homes, including and extending beyond Woodacre. The water recycling alternative was favorably received by the community and formed the basis for this follow-on study of a project that could serve homes in both the Woodacre and San Geronimo communities.

A Draft Project Report was completed in March 2017 that presented alternatives analysis and recommendations focused around the potential use of recycled water for irrigation of the San Geronimo Golf Course. Subsequently, in the spring of 2017 the golf course property was put up for sale and purchased by The Trust for Public Land. While the golf course remained in operation through 2018, it is currently closed. Planning is underway for the property, which is anticipated to include community outreach. Since future uses are uncertain, this report includes wastewater recycling alternatives that would accommodate a golf course, as well as other uses. New uses of the property will continue to have water needs that can be supplied by recycled water. It is assumed that potential future uses could include habitat restoration, park, open space, event center, agriculture, or other public/community services.



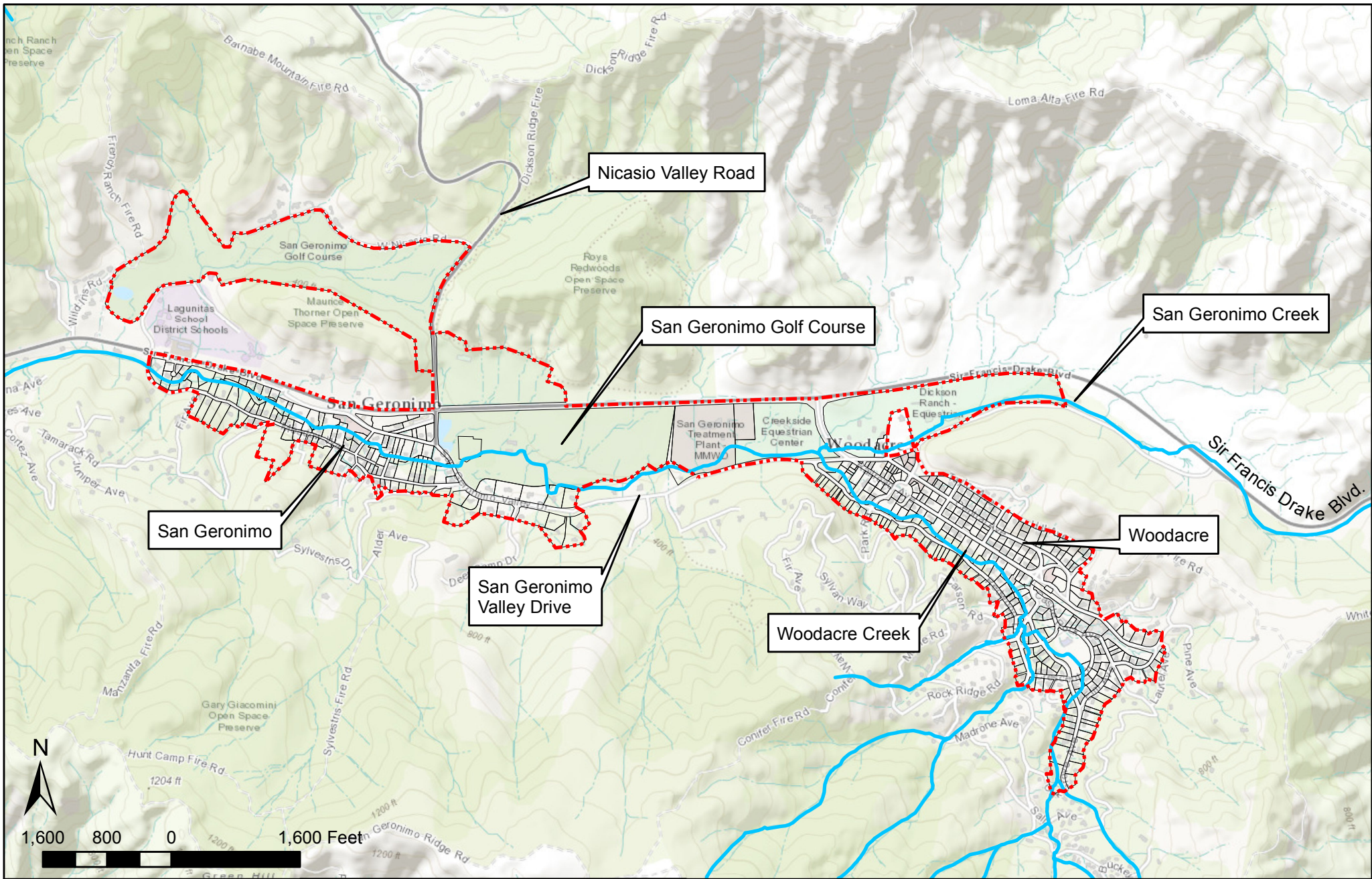

DATE:	12/12/2016
PROJECT:	WOODACRE WW
PROJECT NO.:	1600073
DRAWN:	DD
APPROVED:	NH



**STUDY AREA**

**FIGURE  
ES-1**

## EXISTING WASTEWATER DISPOSAL PRACTICES

There are no public sewers serving the Woodacre-San Geronimo study area or other parts of the San Geronimo Valley. All properties in the study area rely on individual onsite septic systems for sanitary waste treatment and disposal. This typically includes a septic tank for collection and settling of solids, with some type of leaching system for disposal (percolation) of the liquid into the soil. Most of the properties in the area were developed prior to the adoption of current County Codes. Gravity systems are most common, although more recent development has included the use of alternative systems, such as mounded, pressure distribution and sub-surface drip dispersal fields, and advanced treatment units.

There are many existing septic systems in the Woodacre and San Geronimo communities with unknown construction features, indicating the likelihood of an antiquated or questionable design that differs significantly from modern codes and practices. Review of County records shows less than half of the developed properties have septic system permit information on file with Marin County EHS. In 2004-2005 voluntary (confidential) septic system inspections conducted as part of a County-wide outreach effort (“Septic Matters Program”) found roughly two-thirds of the systems inspected in Woodacre to have marginal to unacceptable operating conditions due to many of the following conditions and factors:

- System age, pre-dating modern standards and codes
- Small systems, undersized for current uses
- Additional living units, placing increased demand on sewage disposal systems
- Small parcel size with high intensity of development and limited remaining area for sewage disposal
- Restricted access to yard areas for system maintenance and repair
- Unpermitted repairs and graywater systems
- Shallow depth to groundwater, including seasonal saturation at or near ground surface
- Shallow soils and marginal soil permeability
- Close proximity to streams and local drainages

File and field reviews conducted as part of the 2011 study of Woodacre Flats revealed information consistent with the above findings. Additional review of septic system file information and site conditions for the properties in the San Geronimo portion of the study area showed many of the same septic system constraints and practices.

Although not located within the Woodacre-San Geronimo study area, it is important to note that there are some existing “large-flow” onsite wastewater systems, in the range of 1,500 to 10,000 gallons per day (gpd) design capacity, providing onsite wastewater treatment and disposal for development on properties bordering or near the study area. These wastewater systems, which employ advanced/secondary treatment and onsite disposal using pressure distribution and/or drip dispersal methods, include Spirit Rock Meditation Center, Lagunitas School, and French Ranch development. These systems are regulated under waste discharge requirements issued by the Regional Water Board and operating permits issued by the Marin County EHS. The wastewater system for the San Geronimo Golf Course Clubhouse also falls in the category of a large-flow system, although it is a much older, conventional septic tank–gravity leachfield system constructed in 1965, and is in need of upgrading, expansion or replacement to conform to current practices.

## **SERVICE AREA**

Wastewater improvement projects are planned and developed around a given geographical area termed the “service area”. The service area provides the basis for estimating wastewater facility requirements, project alternatives and costs. Delineating the service area is often an iterative process, whereby initial boundaries are assumed for feasibility analysis, and subsequently adjusted in response to findings, recommendations and other factors, which is the case for this project.

### **2011 Woodacre Flats Study Area**

The 2011 Wastewater Feasibility Study for Woodacre Flats addressed a service area encompassing approximately 150 mostly residential parcels in the low-lying portions of the community of Woodacre. Out of the study came the identification of a wastewater recycling alternative centered around the San Geronimo Golf Course that could potentially support a larger service area, which was favorably received by the community.

### **Woodacre-San Geronimo Service Areas**

The current study was undertaken to evaluate the feasibility of a community wastewater system to serve a larger study area, including additional homes in Woodacre Flats plus homes in a portion of San Geronimo located in similar valley areas near the Golf Course. The study area encompasses developed properties believed to be in most need of wastewater improvements and where residents have expressed the greatest level of interest in studying possible sewerage alternatives. There are a total of approximately 360 developed parcels within the larger study area, with about two-thirds in Woodacre and one-third in San Geronimo.

The approach to this project does not anticipate a condition or requirement for mandatory connection to community wastewater facilities for all properties in the study area or for any particular properties. It does, however, include the limitation that the facilities be planned and implemented to serve existing developed properties, with allowance for a modest amount of expansion for low-incoming housing, child day care facilities or similar community needs.

There is varied property owner interest in connection to community wastewater facilities, as well as differing wastewater improvement needs from property to property. Although not economically most efficient, the types of wastewater collection systems evaluated for the project lend themselves to providing service to a mix of “connected” and “non-connected” properties along the sewer route.

Based on the above, feasible project alternatives were formulated with different configurations and capacities to serve all or portions of the 360 developed properties in the study area as discussed further in the description of alternatives and estimation of wastewater flows.

## **ESTIMATED WASTEWATER FLOWS**

Information regarding wastewater flows is important for assessing the required capacity of collection, treatment, storage and recycling/disposal facilities for community wastewater alternatives. Estimated wastewater flows for the study were developed based on the assumed number of parcels to be served, the type of development on the parcels, and review of typical reference data and monitoring information from other small community wastewater facilities.

The Woodacre and San Geronimo service areas consist mainly of single family residential parcels, with a small amount of commercial uses. The commercial uses are mainly the types that generate wastewater volumes similar to or less than single family residences (e.g., offices, shops, Post Office, small apartments). Noted exceptions are two commercial uses: (1) Two Bird Café, a small restaurant; and (2) the San Geronimo Golf Course Clubhouse, which includes a restaurant, bar and banquet facilities in addition to restroom use for employees and golfers. The estimation of wastewater flows was made by applying a typical unit wastewater flow for residential use for all properties, with an added allowance for the Two Bird Café and Golf Course Clubhouse based their respective food service activities and higher volume of wastewater generation.

Unit wastewater flows in gallons per day (gpd) per single family residence (or equivalent) were developed from review of daily and monthly flow data for a recent six-year period for three small community wastewater systems: (1) French Ranch development, (2) Marshall Community Wastewater Facility, and (3) Lake Canyon Community Services District near Los Gatos in Santa Clara County. Taking into account an allowance for infiltration/inflow (I/I) associated with conventional gravity sewers, the following estimated unit wastewater flows were selected for assessing community wastewater alternatives:

- 30-day Average Daily Flow, Wet Weather: 120 gpd/parcel
- 30-day Average Daily Flow, Dry Season: 100 gpd/parcel
- Peak Daily Flow Wet Weather: 150 gpd/parcel

The Average Daily Flows are pertinent to the sizing and design of a community wastewater treatment system, wet weather storage facilities (e.g., tanks and ponds), and estimation of annual volumes of recycled water produced. The Peak Daily Wet Weather Flow value is pertinent to: (a) sizing of flow equalization and emergency storage for the community wastewater facility; and (b) sizing of community leachfield facilities, where applicable.

Based on the above, estimated wastewater flows were assigned to different levels of wastewater service/alternatives, with average flows ranging from 26,000 gpd to 44,000 gpd (average wet weather flow) and corresponding peak daily flows ranging from 35,000 gpd to 60,000 gpd.

## **PROJECT ALTERNATIVES**

Project alternatives were initially formulated in consultation with Marin County and Regional Water Board staff, utilizing the results of the 2011 Woodacre Flats study as well as input from members of the community and San Geronimo Golf Course. To provide continuity and a frame of reference, the current study includes non-water recycling project alternatives (updated) from

the 2011 study along with several water recycling alternatives consistent with the project objectives.

While the future use of the golf course property is unknown at this time, this analysis includes the option to use recycled water to irrigate the golf course should that land use remain (**Alternative 4.**) This alternative provides the maximum amount of water for a golf course use, which is dependent on the construction of one or more holding ponds for storage of treated water throughout the wet season. A new **Alternative 5** is added that could still accommodate a golf course use but could also supply recycled water to meet significant water demands of new potential uses. **Alternative 5** includes subsurface drip dispersal of treated water during the wet season rather than surface holding ponds. It is anticipated that some public and visitor serving uses will be retained on the parcel containing the existing clubhouse building and facilities (“Clubhouse Parcel”). Accordingly, the water recycling alternatives still focus on the golf course property as the location for placement of treatment facilities and recycled water uses. Project alternatives are illustrated in **Figure ES-2** and summarized below.

### **Non-Water Recycling Alternatives**

- **Alternative 1 - No Project.** This would involve maintaining the status quo, where individual property owners would be responsible for maintaining and upgrading their own onsite systems, and abatement of septic system failures as directed by Marin County EHS and/or the San Francisco Bay Regional Water Board. Each property owner is responsible for insuring acceptable performance of their system to protect against impacts to groundwater, surface waters and public health.
- **Alternative 2 - Onsite Wastewater Management Program.** This alternative considers the upgrade of onsite systems in conjunction with the formation of a local septic system maintenance and inspection program. The program would be operated under the authority of a wastewater maintenance district, County Service Area or similar public entity covering the boundaries of the selected service area. Financing of individual septic system improvements would be accomplished with grant and/or loan assistance to bring all currently developed properties into conformance with minimum acceptable “repair” standards.
- **Alternative 3 - Community Leachfield – Woodacre Only (176 parcels).** This alternative would provide for the construction of a central wastewater collection system for properties in the Woodacre Flats area only, leading to a community leachfield system located on nearby undeveloped hillside. The area identified for a potential community leachfield site is a wooded knoll along the Fire Road ridgeline northeast of Woodacre on property that is part of the Dickson Ranch. The preferred configuration of this alternative (Option 3B) from the 2011 study included a secondary wastewater treatment system located within the community (Park Street at Central Ave.), with a shallow pressure distribution leachfield. For the current study, this **Alternative 3** has been modified to include a dual (200%) capacity leachfield system with capacity to serve up to an estimated 176 existing residential connections in the Woodacre Flats service area. This would cover about 70% of the developed properties in the Woodacre portion of the study area. No comparable community leachfield facility alternative to serve the San Geronimo portion of the study area was identified.

## Water Recycling Alternatives

- **Alternative 4 – Water Recycling System at San Geronimo Golf Course with Storage Ponds**

**Alternative 4a –Woodacre Only (210 parcels).** This closely matches **Alternative 4** from the 2011 study, the only difference being an expanded capacity to serve up to an estimated 210 parcels in the Woodacre portion of the study area. This would be achieved by expanding the size of the proposed storage Pond #1 on the front nine of the golf course. It would entail the construction of a central wastewater collection system in the Woodacre service area, a wastewater transmission line to the San Geronimo Golf Course (via San Geronimo Valley Drive or Sir Francis Drake Boulevard), a tertiary treatment plant (30,000 gpd capacity) located in the golf course maintenance area, a holding pond on the southeastern portion of the golf course (near green #2) for winter storage of recycled water, and seasonal reuse of the recycled water for spray irrigation of the golf course turf grass. The wastewater would be treated to meet State requirements for disinfected tertiary recycled water, and would be integrated into the existing golf course irrigation system to reduce the amount of raw water currently supplied from MMWD.

**Alternative 4b –Woodacre & San Geronimo, Partial Capacity (270 parcels).** This alternative would be an expansion of **Alternative 4a**, including wastewater service to approximately 75% of the developed properties in both Woodacre and San Geronimo. It would include wastewater collection facilities throughout both communities, with the assumption that approximately 75% of the property owners would opt to connect to the system. Those not connecting would continue to be served by their existing/improved onsite septic systems. Compared with **Alternative 4a**, the additional facilities under **Alternative 4b** would include: (a) wastewater collection system in San Geronimo consisting of pressure sewers with individual grinder pumps at each residence; (b) network of pressure sewer lines connecting at San Geronimo Valley Drive and the western driveway entrance into the golf course maintenance area; (c) expansion of the tertiary treatment plant capacity to 35,000 gpd; (d) construction of holding Pond #2 (lower section only) located adjacent to #18 fairway on the back nine of the golf course; and (e) recycled water transmission line and pumping facilities from the treatment plant to Pond #2.

**Alternative 4c –Woodacre & San Geronimo, Full Capacity (360 parcels).** This alternative is an expanded version of **Alternative 4b**, with facilities sized to provide service to essentially all developed properties in the Woodacre and San Geronimo communities. The expanded capacity would be achieved by constructing Pond #2 to full (maximum) size and expanding the tertiary treatment plant capacity to 50,000 gpd. This alternative maximizes the system capacity that can be provided based on largest feasible sizing of Ponds #1 and #2 for wet season holding capacity in conformance with required 100-yr design rainfall criteria.

- **Alternative 5 – Water Recycling System at San Geronimo Golf Course Property without Ponds**

**Alternative 5a – Woodacre Only (250 parcels).** This alternative corresponds generally with **Alternative 4a** in providing a water recycling facility located on the golf course property, with service only to Woodacre. However, it would not include the construction

of holding ponds. It would provide capacity to serve up to an estimated 250 parcels in the Woodacre portion of the study area. Note that this is more than under **Alternative 4a**, which is limited by the capacity of holding pond #1 to 210 parcels. It would entail the following: (a) construction of a central wastewater collection system in the Woodacre service area; (b) wastewater transmission line to the San Geronimo Golf Course property (via San Geronimo Valley Drive or Sir Francis Drake Boulevard); (c) tertiary treatment plant (35,000 gpd capacity) located at one of three potential sites in the golf course clubhouse area; (d) pump station and buried tanks for short-term storage and regulation of recycled water for irrigation/drip dispersal; (e) seasonal reuse of the recycled water for surface irrigation of landscaping, turf grass and open space-environmental restoration areas on the Clubhouse Parcel or other portions of the golf course property (approximately 6.5 acres); and (f) sub-surface drip dispersal of the recycled water during the wet weather season, or at other times in lieu of surface irrigation use; approximately 91.6 acres of drip dispersal areas would be developed on portions of the Clubhouse Parcel. The wastewater would be treated to meet State requirements for disinfected tertiary recycled water, and would be used to reduce the amount of raw water that has historically been supplied to the golf course property from MMWD.

**Alternative 5b –Woodacre & San Geronimo, Partial Capacity (270 parcels).** This alternative would be an expansion of **Alternative 5a**, including wastewater service to approximately 75% of the developed properties in both Woodacre and San Geronimo. It would include wastewater collection facilities throughout both communities, with the assumption that approximately 75% of the property owners would opt to connect to the system. Those not connecting would continue to be served by their existing/improved onsite septic systems. Compared with **Alternative 5a**, the additional facilities under **Alternative 5b** would include: (a) wastewater collection system in San Geronimo consisting of pressure sewers with individual grinder pumps at each residence; (b) network of pressure sewer lines connecting at the intersection of San Geronimo Valley Drive and Nicasio Valley Road and proceeding via Nicasio Valley Road and Sir Francis Drake Boulevard to the selected treatment plant location on the Clubhouse property; (c) tertiary treatment plant capacity of 35,000 gpd; (d) underground recycled water storage tanks and irrigation/dispersal pumping facilities to accommodate up to 33,000 gpd average and 45,000 gpd peak wastewater flows; (e) expansion of the recycled water irrigation facilities to cover approximately 7 acres of landscaping and turf area on the Clubhouse Parcel; and (f) expansion of the winter drip dispersal fields to a total of approximately 1.9 acres on the Clubhouse Parcel.

- **Alternative 5c –Woodacre & San Geronimo, Full Capacity (360 parcels).** This alternative is an expanded version of **Alternative 5b**, with facilities sized to provide service to all developed properties in the Woodacre and San Geronimo communities. The expanded capacity would be achieved by (a) expanding the tertiary treatment plant capacity to 50,000 gpd; (b) expanding underground water storage tanks and pumping facilities to accommodate average and peak wastewater flows of 44,000 gpd and 60,000 gpd, respectively; (c) expanding the recycled water irrigation facilities to cover approximately 9 acres of landscaping, gardens, and open space/restoration area on the Clubhouse Parcel; and (d) expanding winter drip dispersal facilities to a total of approximately 2.5 acres on the Clubhouse Parcel.

## ESTIMATED RECYCLED WATER VOLUMES

The volume of recycled water that will be produced for landscape and turf irrigation uses at the golf course property varies among the several options under **Alternatives 4** and **5** based on the number of parcels served and the corresponding wastewater flows collected and processed through the treatment system. Under **Alternative 4**, since the recycled water will be stored in open ponds subject to rainfall additions and evaporation losses, the recycled water volume will also fluctuate from year-to-year according to prevailing weather conditions. Annual water balance analysis using monthly time steps was conducted for the ponds to estimate the annual volume of recycled water produced and available for recycling uses under each pond alternative and for a range of annual rainfall volumes – average year, 10-year and 100-year recurrence. The results for **Alternative 4 (a, b and c)** are presented in **Table ES-1**. The 100-yr rainfall conditions would be a very rare occurrence, but are included for reference as they are the regulatory design standard for the storage ponds.

**Table ES-1. Estimated Annual Recycled Water Production – Alternative 4, With Ponds**

Alternative	No. of Connections	Average Rainfall (41.6")		10-yr Rainfall (61.3")		100-yr Rainfall (75.3")	
		Acre-foot	Million Gals	Acre-foot	Million Gals	Acre-foot	Million Gals
<b>Alternative 4a</b>	210	28.3	9.2	31.0	10.1	33.1	10.8
<b>Alternative 4b</b>	270	37.6	12.3	41.8	13.6	45.1	14.7
<b>Alternative 4c</b>	360	50.0	16.3	55.9	18.2	60.6	19.7

The annual irrigation water demand for the golf course historically varied between approximately 47 and 53 million gallons, depending on weather conditions. Based on average conditions, recycled water would be able to supply from about 18 to 37 percent of the irrigation demand for the range of alternatives evaluated. During the wet season, water would remain in storage ponds for dry season use.

For **Alternative 5** (without ponds), the annual volume of recycled water produced is a function of the average wastewater flows received and processed through the water recycling facility. The estimated recycled water volumes for **Alternative 5 (a, b and c)** are presented in **Table ES-2**, showing results for the irrigation season only (April – October) and the annual total. The annual total below includes recycled water for normal dry season irrigation plus the amount produced during the normal wet season (November-March). Recycled water could be made available year-round for landscape/turf irrigation and habitat restoration as needed, as well as other off-site uses such fire protection, construction water, and cleaning of sewer lines for large sanitary districts. Based on average conditions, recycled water would be able to supply from about 12 to 17 percent of the irrigation demand of a golf course for the range of alternatives evaluated.



**Table ES-2. Estimated Annual Recycled Water Production – Alternative 5, Without Ponds**

Alternative	No. of Connections	Recycled Water Produced			
		Irrigation Season <sup>1</sup>		Annual Total	
		Acre-feet	Million gallons	Acre-feet	Million gallons
Alternative 5a	250	18.0	5.9	32.4	10.6
Alternative 5b	270	19.4	6.4	34.8	11.3
Alternative 5c	360	25.6	8.3	46.0	15.0

<sup>1</sup> April – October

## ESTIMATED PROJECT COSTS

**Table ES-3** presents a summary of estimated capital costs and annual operation and maintenance (O&M) costs for various project alternatives, along with the estimated cost per residential connection (parcel) served by the system.

### Capital Costs

The estimated capital costs include facilities construction as well as the necessary engineering and environmental studies, project administration, district formation and financing costs. A 15% contingency allowance is also included. Not included are allowances for land/easement costs for the treatment plant, irrigation water storage ponds, tanks, pumps, pipelines and appurtenances that would be located on the Golf Course property, applicable to **Alternatives 4** and **5**. It is anticipated that these costs would be determined through buy-in agreement(s) with the affected parties, also addressing wastewater service provided and recycled water production benefits.

### Annual Operation and Maintenance Costs

The estimated annual O&M costs include costs for administration, labor, equipment, materials, and other expenses required to perform the necessary inspections, treatment plant operation (as applicable), water quality sampling, data analysis, report preparation, pump-outs, and routine maintenance for wastewater facilities. The level and nature of required O&M activities vary according to the wastewater facilities and operating requirements under each alternative. The estimated O&M costs for the recycled water **Alternatives 4** and **5** do not include the activities required of the Golf Course property owner(s) to manage and apply the recycled water for irrigation uses in accordance with State requirements for use of recycled water. The cost estimates also do not include the projected value of the recycled water that would be provided to the Golf Course property by the operation of the project.

**Table ES-3. Summary of Estimated Costs**

Alternative	No. of Equivalent Connections	Capital Costs (\$)		Annual O&M Costs (\$)		
		Total (\$ million)	Per Parcel	Total	Per Parcel <sup>1</sup>	
<b>Non-Water Recycling Alternatives</b>						
1	No Project	-	-	35,000 to 70,000	-	500 to 1,500
2	Onsite Upgrades & Management Program	360	19.2	53,300	348,480	968
3	Woodacre Fire Road Community Leachfield	176	6.6	37,700	159,610	907
<b>Golf Course Property Water Recycling Alternatives – With Ponds</b>						
4a	Woodacre Only One Storage Pond	210	9.6	45,600	291,540	1,356
4b	Woodacre-San Geronimo, Partial (75%)	270	12.7	46,900	346,560	1,260
4c	Woodacre-San Geronimo, Full (100%)	360	14.3	39,800	366,470	1,004
<b>Golf Course Property Water Recycling Alternatives – Without Ponds</b>						
5a	Woodacre Only	250	9.8	39,200	348,810	1,368
5b	Woodacre-San Geronimo, Partial (75%)	270	11.7	43,900	365,860	1,330
5c	Woodacre-San Geronimo, Full (100%)	360	13.5	37,500	417,580	1,144

<sup>1</sup> Per parcel costs for Alternatives 4(a-c) and 5(a-c) account for 5 ESDs assigned to Clubhouse Parcel.

## COMPARATIVE REVIEW AND RECOMMENDED PROJECT

A comparative review was made of the advantages and disadvantages of the various project alternatives with respect to regulatory compliance, environmental impacts, reliability, energy use and greenhouse gas emissions, water conservation/water recycling, land use, and costs. Based on this review, **Alternative 5c** (maximum water recycling without storage ponds) was determined to be the “apparent best alternative” and the recommended project; it has the lowest estimated capital cost per parcel. **Alternative 5c** would include collection, treatment, and recycling of wastewater for landscape, gardens and open space irrigation at the San Geronimo Golf Course Clubhouse property, with capacity to serve up to approximately 360 parcels in the Woodacre-San Geronimo study area. The system would have a capacity to accommodate an estimated average daily flow of approximately 44,000 gpd and peak flow of 60,000 gpd. Under average year rainfall conditions, the project would produce an average of approximately 25.6 acre-feet (8.3 million gallons) of recycled water per year for seasonal landscape, turf and open

space irrigation and habitat restoration needs on the Clubhouse Parcel, with an additional 20.4 acre-feet (6.7 million gallons) available during the remainder of the year (depending on weather conditions) for additional irrigation needs (e.g., low rainfall years) and other potential recycled water uses, such as fire protection, construction water, and sewer line cleaning. **Alternative 4c** (water recycling with ponds) was ranked second highest in preference; it would provide the greatest amount of water conservation benefit for golf course operations and is fourth lowest in estimated capital cost (per parcel).

The main facilities for **Alternative 5c** include: (a) wastewater collection systems extending throughout the Woodacre and San Geronimo service areas using a combination of conventional gravity sewers and pressure sewers; (b) sewage force mains from Woodacre and San Geronimo areas to the treatment plant location in one of three possible sites on the Clubhouse Parcel; (c) tertiary recycled water treatment plant located in an approximately 10,000 ft<sup>2</sup> area; (d) below-ground storage tanks with capacity for approximately 60,000 gallons of recycled water and associated irrigation and drip dispersal pumping systems; (e) recycled water irrigation facilities extending over approximately 9 acres of landscaping, gardens and open space area on the Clubhouse Parcel; and (f) winter season dispersal of tertiary treated water to approximately 2.5 acres of land on the Clubhouse Parcel.. **Figure ES-3** is a map showing the location and layout of key facilities for the recommended project, **Alternative 5c**.

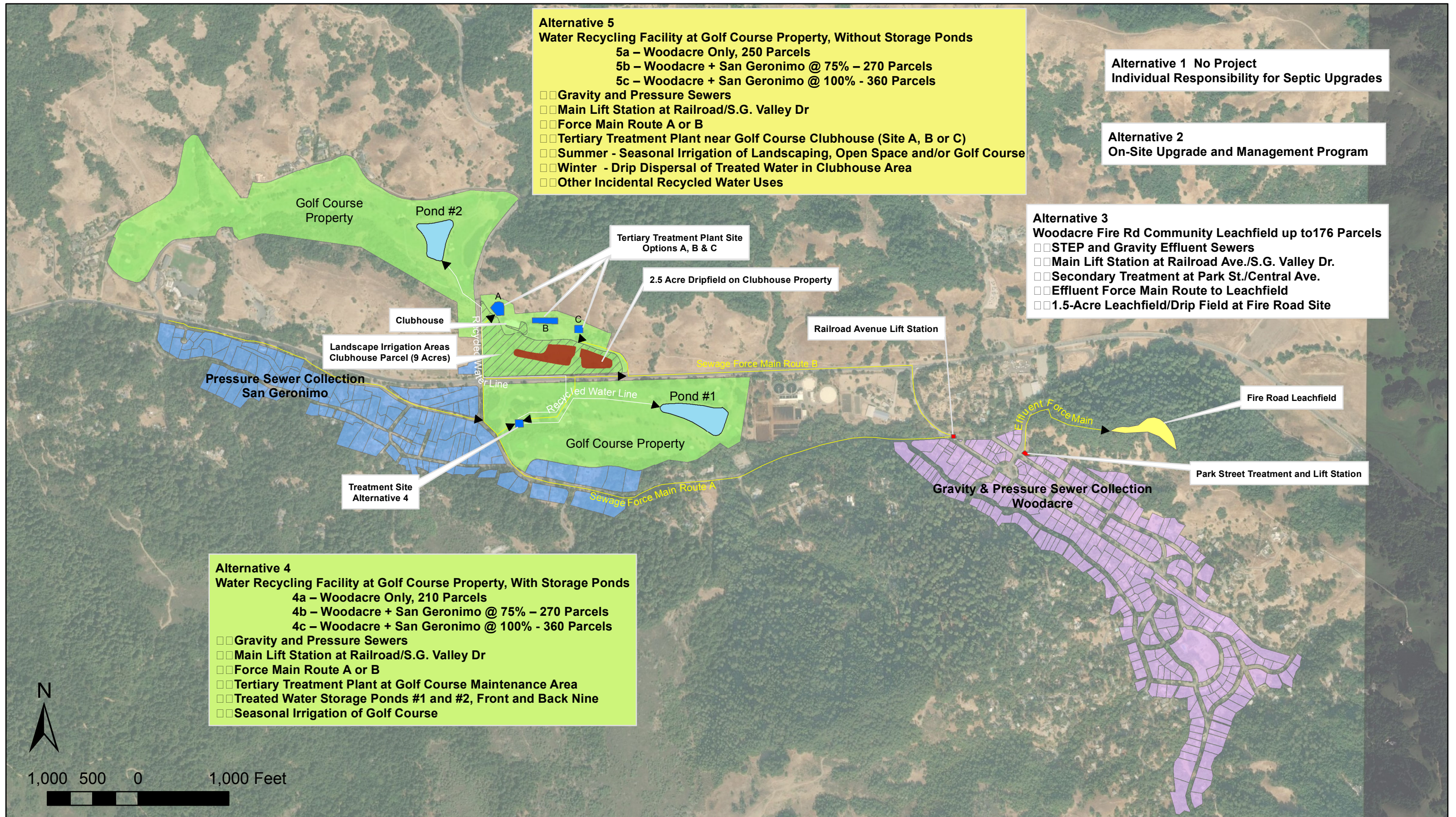

**Alternative 5**  
**Water Recycling Facility at Golf Course Property, Without Storage Ponds**  
 5a – Woodacre Only, 250 Parcels  
 5b – Woodacre + San Geronimo @ 75% – 270 Parcels  
 5c – Woodacre + San Geronimo @ 100% - 360 Parcels

- Gravity and Pressure Sewers
- Main Lift Station at Railroad/S.G. Valley Dr
- Force Main Route A or B
- Tertiary Treatment Plant near Golf Course Clubhouse (Site A, B or C)
- Summer - Seasonal Irrigation of Landscaping, Open Space and/or Golf Course
- Winter - Drip Dispersal of Treated Water in Clubhouse Area
- Other Incidental Recycled Water Uses

**Alternative 1** No Project  
 Individual Responsibility for Septic Upgrades

**Alternative 2**  
 On-Site Upgrade and Management Program

**Alternative 3**  
**Woodacre Fire Rd Community Leachfield up to 176 Parcels**

- STEP and Gravity Effluent Sewers
- Main Lift Station at Railroad Ave./S.G. Valley Dr.
- Secondary Treatment at Park St./Central Ave.
- Effluent Force Main Route to Leachfield
- 1.5-Acre Leachfield/Drip Field at Fire Road Site

**Alternative 4**  
**Water Recycling Facility at Golf Course Property, With Storage Ponds**  
 4a – Woodacre Only, 210 Parcels  
 4b – Woodacre + San Geronimo @ 75% – 270 Parcels  
 4c – Woodacre + San Geronimo @ 100% - 360 Parcels

- Gravity and Pressure Sewers
- Main Lift Station at Railroad/S.G. Valley Dr
- Force Main Route A or B
- Tertiary Treatment Plant at Golf Course Maintenance Area
- Treated Water Storage Ponds #1 and #2, Front and Back Nine
- Seasonal Irrigation of Golf Course

DATE:	2/4/2019
PROJECT:	WOODACRE WW
PROJECT NO:	1600073
DRAWN:	MF
APPROVED:	NH



**PROJECT ALTERNATIVES**

**FIGURE ES-2**

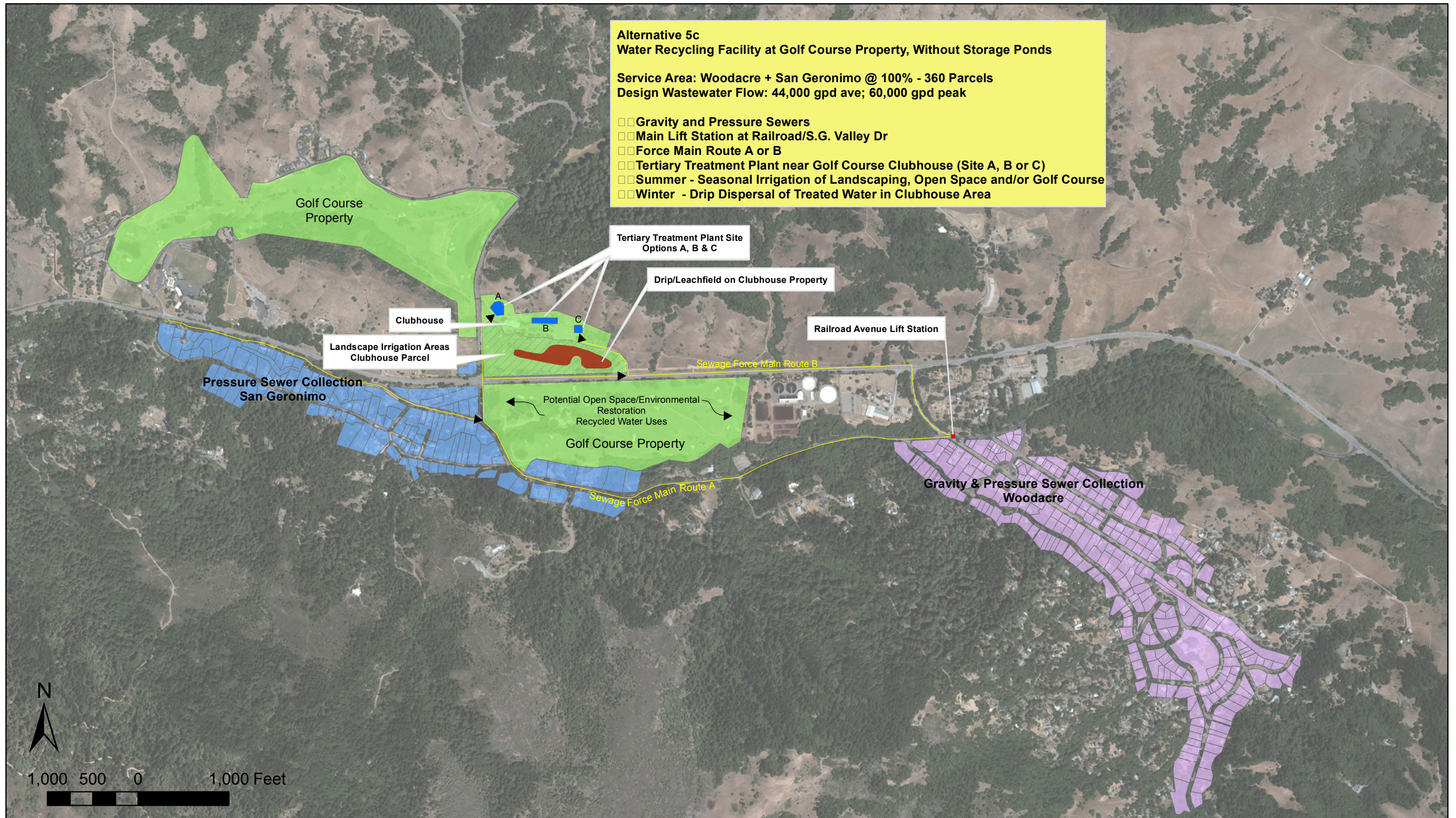

**Alternative 5c**  
**Water Recycling Facility at Golf Course Property, Without Storage Ponds**

**Service Area: Woodacre + San Geronimo @ 100% - 360 Parcels**  
**Design Wastewater Flow: 44,000 gpd ave; 60,000 gpd peak**

- Gravity and Pressure Sewers
- Main Lift Station at Railroad/S.G. Valley Dr
- Force Main Route A or B
- Tertiary Treatment Plant near Golf Course Clubhouse (Site A, B or C)
- Summer - Seasonal Irrigation of Landscaping, Open Space and/or Golf Course
- Winter - Drip Dispersal of Treated Water in Clubhouse Area

Tertiary Treatment Plant Site  
 Options A, B & C

Drip/Leachfield on Clubhouse Property

Railroad Avenue Lift Station

Clubhouse

Landscape Irrigation Areas  
 Clubhouse Parcel

Pressure Sewer Collection  
 San Geronimo

Potential Open Space/Environmental  
 Restoration  
 Recycled Water Uses

Golf Course Property

Gravity & Pressure Sewer Collection  
 Woodacre



DATE:	2/4/2019
PROJECT:	WOODACRE WW
PROJECT NO:	1600073
DRAWN:	MF
APPROVED:	NH



**RECOMMENDED PROJECT ALTERNATIVE**

**FIGURE  
 ES-3**

## SECTION 1: INTRODUCTION AND BACKGROUND

This report presents the results of a study regarding the feasibility of developing a community sewer system and tertiary water recycling treatment facility for properties currently served by onsite wastewater systems (septic systems) in the San Geronimo Valley area of Marin County (**Figure 1-1**). The particular geographical focus of the study (“Study Area”) are the low-lying and more densely developed portions of the unincorporated communities of Woodacre and San Geronimo, including up to approximately 360 existing developed properties, primarily single family residences. The aim of the project is to remedy public health and environmental pollution problems while providing a local source of recycled water for water conservation. The recycled water would be used to irrigate a golf course, parks and open space, habitat restoration, as well as for other public and visitor-serving uses. There are also markets for trucked water uses for dust control, fire suppression, cleaning of sewer lines, etc.

Woodacre and San Geronimo are located in the San Geronimo Creek watershed, tributary to Lagunitas Creek which is listed as impaired for pathogens, nutrients, and sediment. The Tomales Bay Pathogen Total Maximum Daily Load (TMDL) of 2005 identifies lower San Geronimo Creek as the second greatest source of fecal coliforms entering Tomales Bay, after Walker Creek, and requires the County of Marin to take action to address failing septic systems.

Inspections of existing septic systems in the winters of 2004-05 and 2007-08 in Woodacre found a high percentage (77%) of homes had marginal or failing systems. Water quality monitoring in Woodacre Creek by the Tomales Bay Watershed Council (TBWC) during the same time period found generally high levels of total and fecal coliform, nitrates and ammonia, as well as methylene blue active substances (MBAS), a component of detergents. This led to their identification of Woodacre as a high priority for correction of failing septic systems, the formation of a local homeowner steering group (Woodacre Flats Wastewater Group), and eventually the initiation of a wastewater feasibility study for the “Woodacre Flats” area sponsored by the County of Marin with funding from the local community, the County, and the U.S. EPA.

The “Woodacre Flats Wastewater Feasibility Study” was completed by Questa Engineering Corporation in July 2011, identifying and evaluating wastewater improvement alternatives for approximately 150 parcels in the most problematic areas of the community affected by high groundwater, drainage, clayey soils, small parcel size and age of systems. The study identified two promising options: (1) a local community leachfield option with limited capacity for properties in Woodacre; and (2) a wastewater recycling alternative centered around the San Geronimo Golf Course that could potentially support a larger number of homes, including and extending beyond Woodacre. The water recycling alternative was favorably received by the community and provided the impetus for a follow-on study of a project that could serve homes in both the Woodacre and San Geronimo communities.

Partway through this feasibility study, the golf course property was purchased by The Trust for Public Land. Planning is underway for the future use of the property, which will include community outreach. Since the future uses are uncertain, this report includes wastewater recycling alternatives that would accommodate a golf course, as well as other potential uses. Potential changed uses of the site will continue to have water needs that can potentially be supplied by recycled water, which is addressed in the project alternatives.



**Legend**

— Study Area

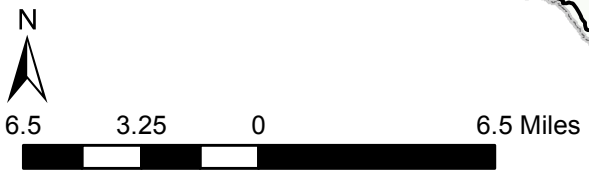

**QUESTA**  
ENGINEERING CORP.

*Civil  
Environmental  
& Water Resources*

(510) 236-8114  
FAX (510) 236-2423  
questa@questaec.com

P.O. Box 70356 1220 Brickyard Cove Road Point Richmond, CA 94807

**Woodacre - San Geronimo  
Wastewater Recycling Study  
Marin County, California**

**Figure 1-1  
Location Map**

This community-based project is sponsored and managed by the County of Marin, with public input from a local community steering group (Woodacre/San Geronimo Flats Wastewater Group) with funding assistance provided by a grant from the State Water Resources Control Board (SWRCB) and the County of Marin.

In terms of the organization of this report, following the Introduction, background information on the general study area conditions, existing wastewater practices and concerns are covered in **Sections 2 and 3**. **Section 4** describes the boundaries and wastewater characteristics of the service area covered by the study. **Section 5** summarizes the key regulatory requirements applicable to the wastewater treatment, disposal and recycling alternatives evaluated in the study. The community wastewater and recycling alternatives are presented and described in **Section 6**, including facility requirements and estimated costs for construction and ongoing operation and maintenance. A comparative analysis and review of the alternatives is presented in **Section 7**, including identification of the “apparent best alternative”. **Section 8** presents the recommended facilities project plan, including description of wastewater-water recycling facilities, project implementation plan, and operational plan.



## SECTION 2: STUDY AREA CONDITIONS

### GEOGRAPHICAL SETTING

The Study Area comprises a portion of the unincorporated communities of Woodacre and San Geronimo and the San Geronimo Golf Course property, located in the center and eastern end of the San Geronimo Valley in western Marin County (**Figure 2-1**). There are no municipalities within or near the Study Area.

The Woodacre portion is roughly defined as the area bordered by and adjacent to San Geronimo Valley Drive on the north, Taylor and Central Avenues on the northeast, Redwood Drive on the southwest, and Oak Grove and Elm Avenues on the southeast. The Woodacre area includes 250 developed parcels, primarily the low-lying and most densely developed portions of the community. The developed properties are primarily single family residences, with a small number of commercial occupancies. There are also a small number of undeveloped (vacant) parcels within the boundaries of the Study Area.

The San Geronimo portion encompasses 113 developed residential parcels along San Geronimo Valley Drive, Meadow Way and Sir Francis Drake Boulevard, stretching over a distance of approximately one mile from the San Geronimo Golf Course to the San Geronimo Valley Community Center.

Based on 2010 Census data, the average household sizes in Woodacre and San Geronimo area are 2.27 and 2.24 persons/residence, giving a total Study Area population estimate of about 820 people. Due to the essentially fully-developed conditions of the Study Area, projected population growth is assumed to be negligible.

The 158-acre San Geronimo Valley Golf Course occupies the central part of the Study Area, with portions of the course located on both the south and north sides of Sir Francis Drake Boulevard. While the Golf Course property has been sold and may be converted to other non-golf course uses, the property is integral to the wastewater study, as it represents the area under consideration for locating the wastewater treatment unit, recycled water use areas, and associated storage and distribution facilities. Other notable features in the study area include the Marin Municipal Water District's Water Treatment Plant and two equestrian facilities near Woodacre.

### HYDROLOGY

Woodacre and San Geronimo lie within the watershed of San Geronimo Creek, a year-round stream tributary to Lagunitas Creek and eventually into Tomales Bay (**Figure 2-2**). Woodacre Creek flows through the study area parallel to Redwood Drive, in a southeast-to-northwest direction. Woodacre Creek receives surface runoff and drainage from several small tributary branches and a network of storm drainage channels in the community. The San Geronimo portion of the study area is bisected by San Geronimo Creek.

The ground elevations in the study area range from about 270 to 300 feet above mean sea level (AMSL) in San Geronimo, to about 370 to 400 feet AMSL in the Woodacre area. The surrounding upland portions of Woodacre occupy steeper terrain, with elevations up to about 700 feet AMSL.

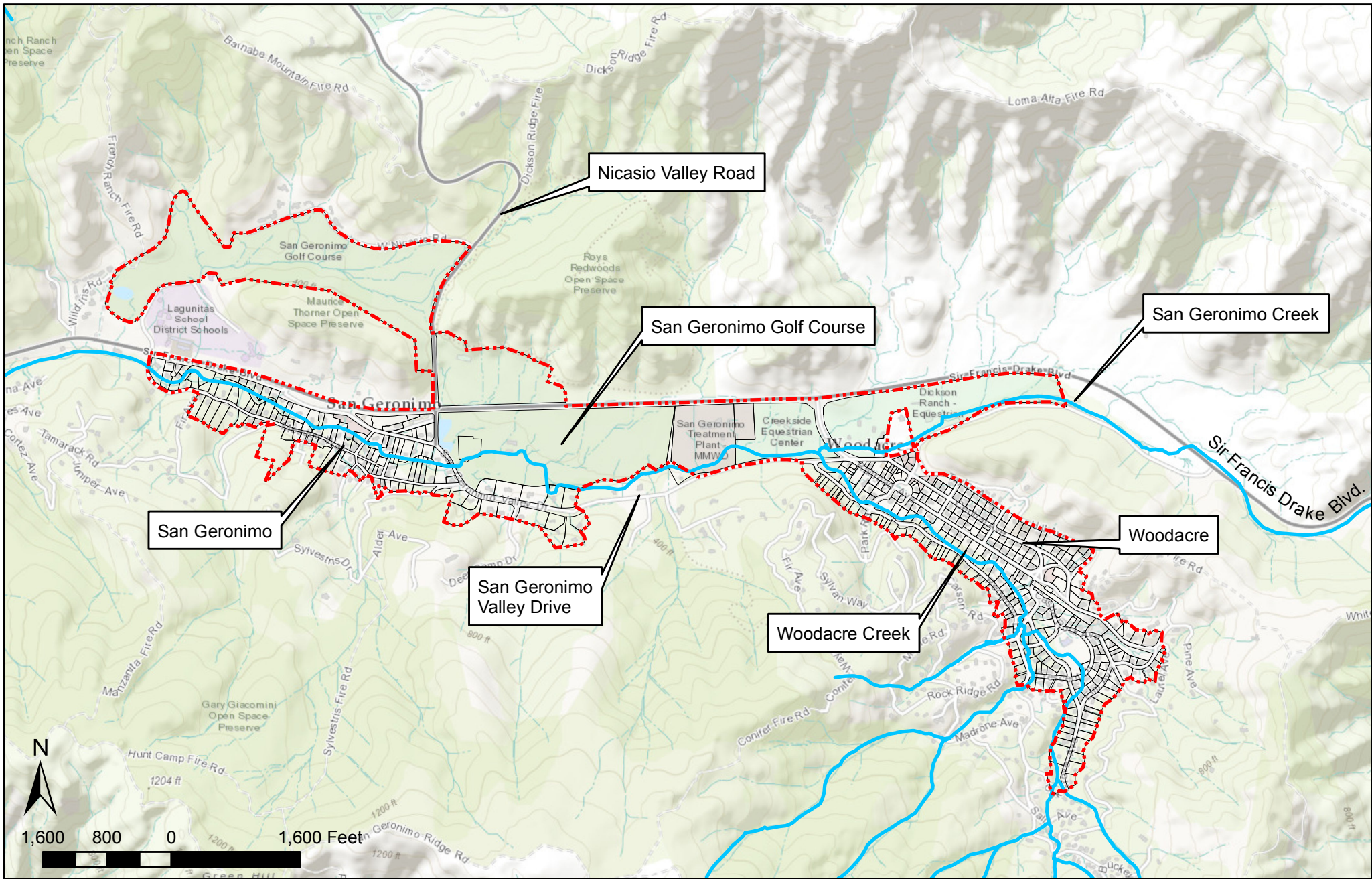

DATE:	12/12/2016
PROJECT:	WOODACRE WW
PROJECT NO.:	1600073
DRAWN:	DD
APPROVED:	NH



**STUDY AREA**

**FIGURE  
2-1**

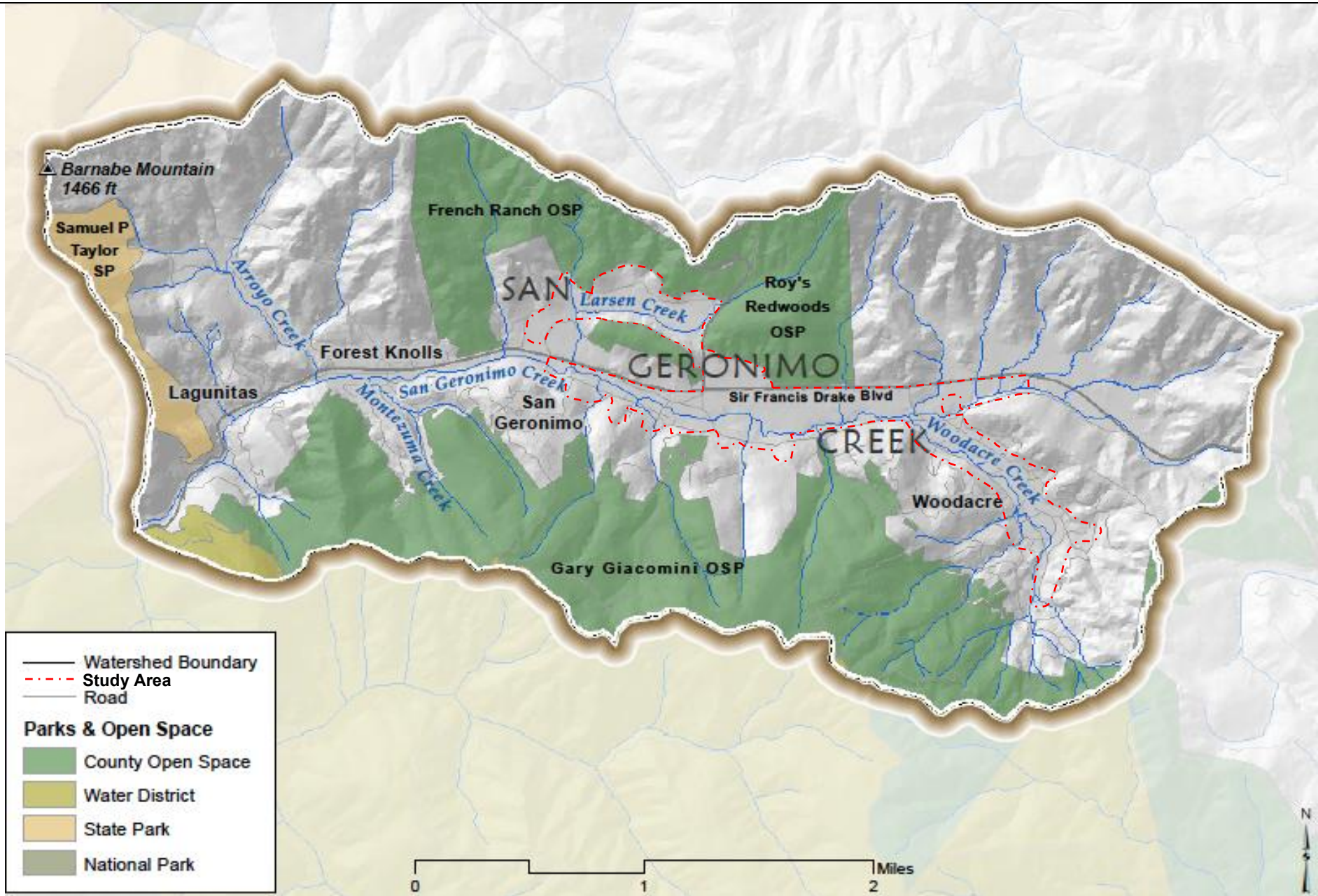

DATE:	12/20/2016
PROJECT:	WOODACRE WW
PROJECT NO.:	1600073
DRAWN:	N/A
APPROVED:	NH
SOURCE:	MARIN COUNTY DPW



## SAN GERONIMO CREEK WATERSHED

FIGURE

2-2

In Woodacre, the local hydrology is strongly influenced by the relatively flat gradients (2 to 3 percent in the Flats), concentrated runoff and drainage from the surrounding steep hills, and alteration of local drainage patterns by roads, the former railroad grade, and development of individual lots. Localized soil saturation and ponding of surface waters is common during the wet season. This has prompted many property owners to install various drainage mitigation measures in yards and around buildings, including curtain drains, sumps, and drainage ditches. San Geronimo experiences some of the same localized surface water ponding and drainage issues as Woodacre, but to a much lesser degree due to the narrower landscape configuration along San Geronimo Creek.

There is no recognized groundwater basin in the Study Area and vicinity. The area is dominated by rock formations of the Franciscan Complex, with spotty groundwater occurrence and generally low yields. There are no municipal or domestic supply wells in the Study Area, but there are believed to be some private agricultural wells in surrounding areas.

Like most of the California coastal areas, the climate is Mediterranean, with wet winters and dry summers. The annual average rainfall for the area is approximately 42 inches, with 85 percent of the annual total typically occurring during the months of November through April. **Table 2-1** presents average monthly rainfall amounts for the Woodacre area based on rainfall measurements at Woodacre Fire Station, located within the study area. The table also shows monthly rainfall estimates for 10-year and 100-year frequencies as determined statistically from long-term rainfall records at San Rafael and Kentfield (see **Appendix F**).

**Table 2-1. Monthly Rainfall for Woodacre, California  
(inches)**

Month	Average Year	10-Year	100-Year
January	5.13	7.56	9.28
February	8.01	11.81	14.49
March	9.39	13.84	16.99
April	7.53	11.10	13.62
May	5.29	7.79	9.57
June	2.40	3.54	4.34
July	1.03	1.51	1.86
August	0.28	0.41	0.51
September	0.05	0.07	0.08
October	0.09	0.13	0.15
November	0.39	0.58	0.71
December	2.05	3.02	3.70
<b>Total</b>	<b>41.6</b>	<b>61.3</b>	<b>75.3</b>

## GEOLOGY AND SOILS

### Geology

The regional geology consists of the folded, faulted, and sheared bedrock of the Franciscan Complex, which is an accretionary mélangé comprised of greywacke, chert, serpentinite, schist, greenstone, and other rock types. The Franciscan Complex was formed 65 to 190 million years ago by the subduction of the Farallon Tectonic Plate and the northwest movement of the Pacific Plate to the North American Plate. Subsequent compression, uplift and faulting occurred during

the Miocene and Pliocene epochs of the Tertiary Period (between 5 and 15 million years ago). The current tectonic setting is related to the movement along the northwest-southeast trending faults such as the San Andreas and Hayward Faults.

Locally, the Woodacre area consists of a valley with ridges rising up on both the northeast and southwest sides, and at the southeasterly end. Along the western side, the ridge is formed mainly of sandstone. In contrast, the eastern ridge (Fire Road area) and the uplands in the southern end of the valley consist of Franciscan Melange, including a mixed composition of serpentine, greenstone, chert, shale and sandstone blocks in a clayey/shale matrix. A sizeable sandstone block has been identified along the northern end of the eastern ridge. The San Geronimo portion of the study area lies almost entirely in the San Geronimo Valley floor, bounded by wooded uplands along the southern side.

## Soils

Soils in Woodacre and San Geronimo are derived from the accumulation of materials that have washed into the valley from the surrounding upland slopes and ridges. The soils are deep in some areas, but are generally somewhat poorly to very poorly drained, with seasonal groundwater levels less than 3 feet from ground surface. Deeper, sandy alluvial soils occur along the drainageways.

According to the Soil Survey of Marin County, soils in the Woodacre and San Geronimo area are primarily Blucher-Cole Complex, 2 to 5 percent slope, which occur in basins and alluvial fans. The distribution of soils in this complex is roughly as follows:

- **40% Blucher Silt Loams.** Blucher soils occur near drainageways and are deep and somewhat poorly drained, with seasonal high water table normally between 3.5 to 5 feet below ground surface. Permeability is typically moderate in near surface soils (to about 2-feet deep), and slow at deeper depths.
- **30% Cole Clay Loam** – Cole soils occur on basin rims and depression areas; they are very deep and somewhat poorly drained, with seasonal high water table normally between 1.5 to 3 feet below ground surface. Permeability is typically slow in Cole soils.
- **30% Clear Lake Soils** – Clear Lake soils occur in depressions and slopes less than 2%; they are similar to Cole soils, but more clayey and with slow permeability.
- **Cortina Soils** - Cortina soils are deep, gravelly sandy loams that have developed from alluvial deposits along streams.

Soils in the adjacent hills and uplands along the edges of the study area, e.g., along Redwood Drive in Woodacre and south of Meadow Way, are mapped as Dipsea-Barnabe gravelly loams and clay loams. These soils are derived from weathering of sandstone and shale, well drained, varying from shallow to moderately deep over bedrock, typically on steep to very steep slopes, approaching 50% or greater.

## WATER SUPPLY

**Water Supply Facilities.** The San Geronimo Valley receives water service from the Marin Municipal Water District (MMWD). The District provides drinking water to nearly 200,000 customers in Central and Southern Marin County, as well as raw water for irrigation uses. The District also operates the Las Gallinas Valley Water Recycling Facility which serves up to 2 million gallons of recycled water per day to 350 customers in northern San Rafael, which is about 15 miles from the San Geronimo Valley. There are no existing water recycling facilities or uses within or near the project area. **Figure 2-3** shows District boundaries and location of some of the major facilities in the vicinity of the project.

Seventy-five percent of the district's water comes from the local watersheds, and the rest comes from the Russian River through a contract with the Sonoma County Water Agency. MMWD has seven reservoirs that store local watershed runoff - Lagunitas, Phoenix, Alpine, Bon Tempe, Kent, Nicasio, and Soulajule. Water is treated at three treatment plants - Ignacio, Bon Tempe and San Geronimo Valley.

The San Geronimo Water Treatment Plant is located to the east end of the San Geronimo Golf Course and adjacent to the project study area. The San Geronimo Plant receives water from Kent Lake and Nicasio Reservoir via raw water pipelines and booster pump station located on Sir Francis Drake Boulevard.

**Water Use and Trends.** According to MMWD's 2015 Water Management Plan, the 5-yr base water use in the district was 147 gallons per day per capita (GPCD) for 2003-2007. In 2015 the water use 110 GPCD, well within the district's 2020 water use target of 124 GPCD. Through continued implementation of demand management measures and other conservation activities, the district expects that it will continue to meet its water use target in the year 2020 and beyond.

Based on MMWD water conservation commitments and accomplishments, water demand levels in the district are projected to remain at levels that can be supplied from existing water sources for the district's 2040 planning horizon (UWMP, 2015). As a result, no future potable water supply projects are currently considered necessary to increase the amount of available potable water supply.

**Water Quality.** Treated water supplied by MMWD meets or surpasses all drinking water requirements set by the State Water Board and the EPA. MMWD's 2018 Annual Water Quality Report is available at: <https://www.marinwater.org/DocumentCenter/View/6308/2018-AWQR?bidId=>.

**Water Rates.** Water rates for residential customers are determined from a fixed, four-tiered billing structure, which ranges from \$4.07 to \$19.45 per one hundred cubic feet (CCF)<sup>1</sup> of water, based on the metered water use. Water rates for non-residential customers range from \$3.98 to \$16.26 per CCF, based on the percentage of actual water use compared to the annual water budget ("baseline") for the facility. A similar billing structure is applied to single family irrigation customers, with rates ranging from \$5.14 to \$10.76 per CCF related to percentage of their "baseline" allowance.

---

<sup>1</sup> One CCF equals 748 gallons.

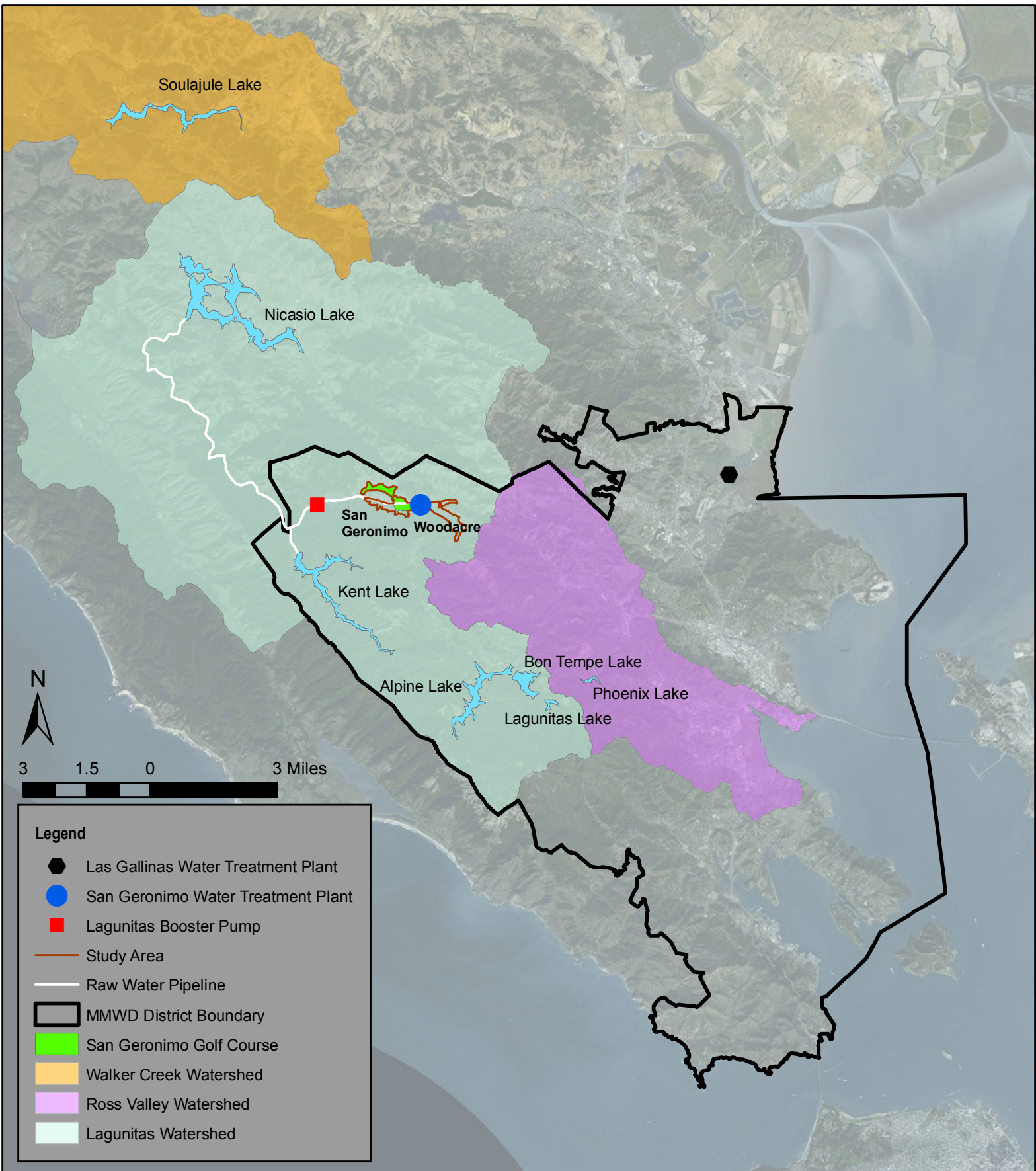

DATE: 12/12/2016  
 PROJECT: WOODACRE WW  
 PROJECT NO.: 1600073  
 DRAWN: DD  
 APPROVED: NH



**KEY WATER  
 SUPPLY FACILITIES  
 (MMWD)**

**FIGURE  
 2-3**

The San Geronimo Golf Course, one of two large raw water users in MMWD service area, has historically been supplied approximately 150 acre-feet per year of raw water for golf course irrigation, which is taken from the raw water main at two intake points along Sir Francis Drake Boulevard. Current MMWD base water rates for raw water and recycled water are \$1,843 and \$1,381 per acre-foot, respectively.

**Groundwater.** There are no known domestic water supply wells in Woodacre or San Geronimo; however, there are known to be a few scattered agricultural wells in surrounding areas.

## WATER QUALITY

Monitoring and protection of water quality in Tomales Bay and tributary watersheds, including Lagunitas Creek and its tributary streams, falls under the authority of the San Francisco Bay Regional Water Quality Control Board (Regional Water Board.) The Regional Water Board is charged with the responsibility of ensuring maintenance of water quality conditions at levels that are protective of the beneficial uses in the Bay and tributary streams, which include shellfish harvesting, water contact recreation, and noncontact water recreation, as well as aquatic habitat uses. The Water Quality Control Plan for the San Francisco Bay Region identifies the following beneficial uses of Lagunitas Creek, San Geronimo Creek and Woodacre Creek:

- a. Agricultural Supply
- b. Municipal and Domestic Supply
- c. Freshwater Replenishment
- d. Water Contact Recreation
- e. Noncontact Water Recreation
- f. Warm Fresh Water Habitat
- g. Cold Fresh Water Habitat
- h. Wildlife Habitat
- i. Preservation of Rare and Endangered Species
- j. Fish Migration
- k. Fish Spawning

Many years of monitoring results have shown that Tomales Bay and its main tributaries, Lagunitas Creek, Walker Creek and Olema Creek, are impaired by pathogens, as reflected by high fecal coliform bacteria concentrations (Regional Water Board, July 2005). The presence of pathogens in the Bay and tributary streams poses potential health risks to shellfish consumers, recreational users and other water uses. Because of these conditions, these waters have been formally “listed” in accordance with Section 303(d) of the Federal Clean Water Act (CWA) as impaired water bodies. Septic systems in the Tomales Bay watershed are a potential contributor to the water quality impairment.

Water quality sampling of Woodacre Creek and local storm drains in recent years has shown elevated levels of coliform bacteria, nitrate, ammonia and surfactants, in some cases exceeding receiving water quality standards. These influences on water quality may be attributable to the high density of older septic systems combined with the difficult drainage and soil conditions in Woodacre and San Geronimo, especially in the Flats. Impacts on water quality locally can be carried downstream to Lagunitas Creek and eventually to Tomales Bay.

To further investigate the potential sources of bacteriological impacts, a microbial source tracking study of Woodacre Creek and San Geronimo Creek was conducted in winter 2016 to



summer 2017. This was a collaborative effort of the Marin County EHS, MMWD, Tomales Bay Watershed Council, Woodacre/San Geronimo Wastewater Group, and the San Geronimo Valley Planning Group. The study collected water samples from three locations: (1) Woodacre Creek; (2) San Geronimo Creek (upstream) above confluence with Woodacre Creek; and (3) San Geronimo Creek (downstream) at Meadow Way Bridge. Samples were collected on four different dates, reflecting different streamflow conditions: wet weather (12/16/16; 2/15/17); spring (5/10/17), and dry summer (7/10/17.) Quantitative polymerase chain reaction (qPCR) analysis was used to detect the presence of host-specific bacteria from human, horse, ruminant, and dog *Bacteroides* markers. Study results showed positive evidence of human markers from (1) Woodacre Creek during all sample events, (2) upstream San Geronimo during wet season, and (3) San Geronimo Creek during wet and dry season samples. The project report presenting methodology and results is presented in Appendix K.

The Regional Water Board and Marin County EHS are committed to eliminating faulty septic systems and implementing various onsite wastewater management programs and projects to address the water quality concerns in the Tomales Bay watershed. Under the CWA, the State is required to establish Total Maximum Daily Load (TMDLs) for those pollutants causing water quality impairments to ensure that impaired water bodies attain their beneficial uses. In compliance with the requirements of the CWA, in March 2005, the RWQCB issued its report "*Pathogens in Tomales Bay – Total Maximum Daily Load, Proposed Basin Plan and Staff Report*". The report: (a) documents the basis for the impairment finding; (b) establishes numeric targets for water quality needed to protect beneficial uses; (c) identifies the actual and potential pathogen sources in the watershed; (d) proposes a loading allocation amongst the various contributing pathogen sources to achieve the TMDL; (e) evaluates the linkage between sources and water quality targets; and (f) proposes an implementation plan for achievement of the TMDL goals. The pathogen limits for Tomales Bay and its tributaries are listed in **Table 2-2** below:

**Table 2-2. Tomales Bay TMDL Pathogen Limits  
(mL= milliliter)**

WATERBODY	INDICATOR PARAMETER	TMDL <sup>a,b</sup>	
		Median/Log Mean	90 <sup>th</sup> Percentile
Tomales Bay <sup>c</sup>	Fecal coliform	Median < 14 MPN/100mL	<43 MPN/100mL
Tomales Bay Tributaries <sup>c</sup>	Fecal coliform	Log mean <200 MPN/100 mL	< 400 MPN/100mL <sup>c</sup>

<sup>a.</sup> Based on a minimum of no less than five samples equally spaced over a 30-day period.

<sup>b.</sup> Most Probable Number (MPN) is a statistical representation of the coliform test results.

<sup>c.</sup> All samples should be collected at knee-high depth

The TMDL sets a target of zero discharge of human waste to the waters of Tomales Bay and its tributaries. This is based on the knowledge that human waste can be a significant source of pathogenic organisms, including viruses. Prohibition of human waste discharges into surface waters is consistent with existing water quality plans and policies.

In terms of implementation, the TMDL finds that septic systems that discharge to land in a manner consistent with accepted design standards (for new systems) or according to specific performance standards (for existing/repair systems) would be considered acceptable, providing that they are properly operated and maintained. Compliance with performance standards would also be expected to assure protection of groundwater resources (e.g., drinking water supplies), which can be impacted by improper siting, design, or operation of onsite sewage disposal systems.

## **SECTION 3: EXISTING WASTEWATER TREATMENT AND DISPOSAL PRACTICES**

### **OVERVIEW**

There are no public sewers serving the Woodacre-San Geronimo study area or other parts of the San Geronimo Valley. Similarly, there are no existing supplies or uses of recycled water. All properties in the study area rely on individual onsite septic systems for sanitary waste treatment and disposal. This typically includes a septic tank for collection and settling of solids, with some type of leaching system for disposal (percolation) of the liquid into the soil. Most of the properties in the area were developed prior to the adoption of current County Codes. Gravity systems are most common, although more recent development has included the use of advanced systems installations, such as mounded and pressure distribution disposal fields and advanced treatment units.

There are many existing septic systems in the Woodacre and San Geronimo communities with unknown construction features, indicating the likelihood of an antiquated or questionable design that differs significantly from modern codes and practices. Review of County records shows less than half of the developed properties have septic system permit information on file with Marin County EHS. In 2004-2005, voluntary (confidential) septic system inspections conducted as part of a County-wide outreach effort (“Septic Matters Program”) found roughly two-thirds of the systems inspected in Woodacre and San Geronimo have marginal to unacceptable operating conditions due to many of the following conditions and factors:

- System age, pre-dating modern standards and codes
- Small systems, undersized for current uses
- Additional living units, placing increased demand on sewage disposal systems
- Small parcel size with high intensity of development and limited remaining area for sewage disposal
- Restricted access to yard areas for system maintenance and repair
- Unpermitted repairs and graywater systems
- Shallow depth to groundwater, including seasonal saturation at or near ground surface
- Shallow soils and marginal soil permeability
- Close proximity to streams and local drainages

Many of the properties in the current Study Area have very serious constraints for onsite sewage disposal. **Figure 3-1** illustrates the development conditions and associated sewage disposal constraints typical for most of the properties in the Woodacre Flats area. As indicated, the lot sizes are relatively small (generally about 10,000 square feet), with limited area available for septic system placement between buildings, driveways, walkways, landscaping and patio areas. The ground slopes are flat to gently sloping with relatively shallow soils, contributing to poor drainage and seasonal high groundwater conditions. Many property owners have installed drainage ditches, curtain drains and sumps to rid their yards of water ponding during the rainy season. These drainage systems provide a potential avenue for short-circuiting of sewage effluent into the local storm drain system (and subsequently downstream receiving waters) during certain times of the year. The close proximity between neighboring properties further complicates the local drainage situation and often presents additional setback conflicts for sewage disposal systems.

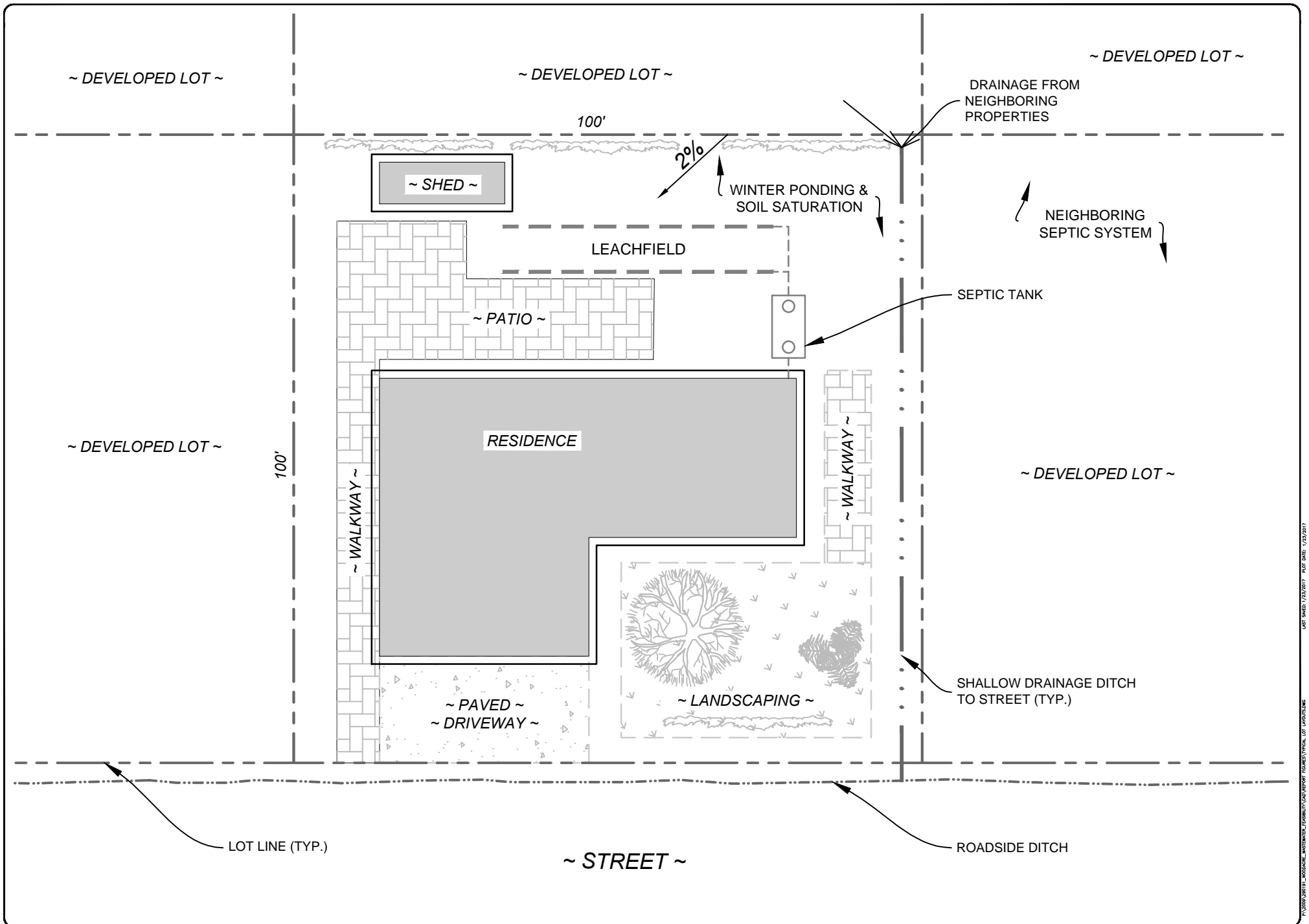

Sheet	Rev.	Date	By	Description	Appr.

Design:	NH/PP
Drawn:	ML
Checked:	PP
Appr'd:	NH

Another area of special concern is the group of homes that border local streams, including Woodacre Creek and San Geronimo Creek. These properties typically have better soil and drainage conditions than the Flats area of Woodacre. However, in many cases the ability to provide suitable horizontal setback distance between the septic system and the edge of the creek is severely limited. **Figure 3-2** illustrates common creekside situations in both Woodacre and San Geronimo, where small gravity flow systems (often seepage pits/beds) are located between the building and the creek and may provide setback distances of as little as 25 to 50 feet between the disposal area and the edge of the creek bank. Some creekside properties have other available land that could be used effectively for sewage disposal with alternative/pumping systems in a way that would meet standard (100-foot) creek setback requirements; however, some properties lack sufficient and suitable land area to meet all setback requirements.

A third example on onsite wastewater conditions, typical of some parts of San Geronimo, is illustrated in **Figure 3-3**. This typifies those properties located a further distance from San Geronimo Creek at the base of the adjacent hillslopes. In these situations, the constraints for onsite wastewater systems are mainly related to shallower soil depths over clayey subsoils, adjacent steep slopes, and limited land area to accommodate shallow dispersal designs dictated by these soil conditions.

## **“SEPTIC MATTERS PROGRAM”**

Individual septic system inspections were conducted in various parts of Marin County in the period of January 2004-August 2005 (by Kit Rosefield) and in winter of 2007-2008 (by Mike Treinen). A large number of these inspections were done in the Woodacre and San Geronimo areas. This work was funded by the County of Marin through grants received from the State Water Resources Control Board and the California Coastal Commission, and was termed the “Septic Matters Program”. The overall goal of the program was to provide community education to homeowners through the completion of free and confidential third-party inspection and testing of septic systems.

The inspections were conducted on a voluntary basis, at the request of individual property owners, and the resulting information particular to any given property was kept confidential (between the inspector and the property owner). A total of 135 inspections were conducted County-wide, with more than half (70) being in the Woodacre and San Geronimo areas. The greatest number of inspections (62) were conducted in the Woodacre community. The large number of inspections in Woodacre was as a result of active local encouragement to participate in the program. The inspections in Woodacre included many systems in the Flats area, but also other properties located in the upland areas, outside the limits of the current wastewater feasibility study.

The septic system inspections were conducted to assess the functioning status of individual systems following the general methodology contained in Marin County’s “Septic System Performance Evaluation Guidelines”. The work included review of permit file information, field inspection and measurements of the septic tank, leachfield system and key site features, and hydraulic load testing of the system. While the location and owners of inspected properties remained anonymous, the overall results of the inspections were compiled and presented to the County by Rosefield and Treinen, and provide a general overview of the functioning status and condition of septic systems in different parts of the County.

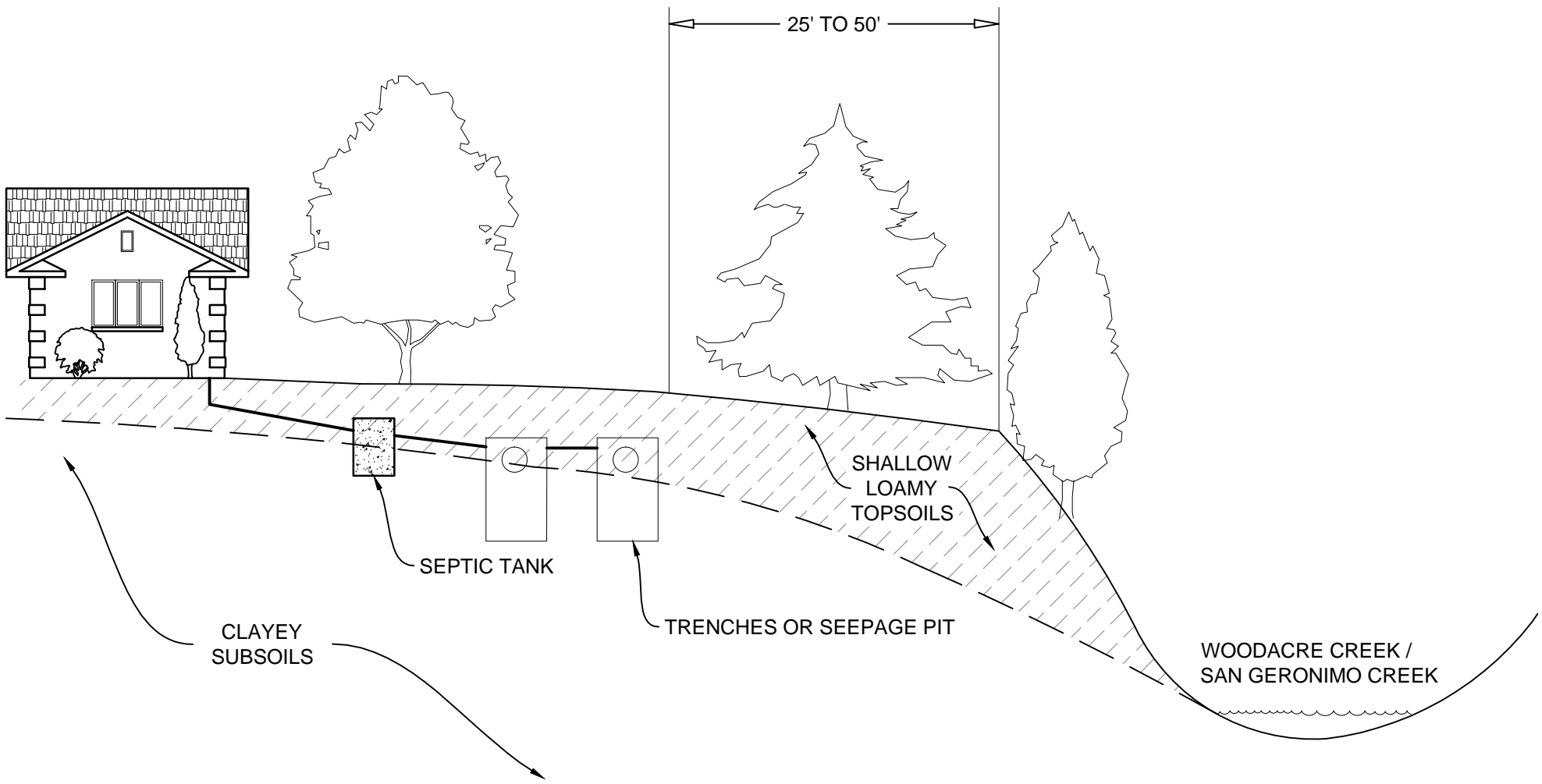

DATE PAVED 1/23/2017 RUP DATE 1/23/2017

**WOODACRE - SAN GERONIMO  
WASTEWATER RECYCLING STUDY**

**QUESTA**  
ENGINEERING CORP.

*Civil  
Environmental  
& Water Resources*

(510) 236-6114  
FAX (510) 236-2423  
P.O. Box 70356 1220 Brickyard Cove Road Point Richmond, CA 94807  
questa@questa.com

Sht.	Rev.	Date:	By:	Description:	App'd:

Design:	NH/MW
Drawn:	DI
Checked:	MW
Appr'd:	NH

**TYPICAL ONSITE CONDITIONS  
CREEKSIDE AREA**

**FIGURE  
3-2**

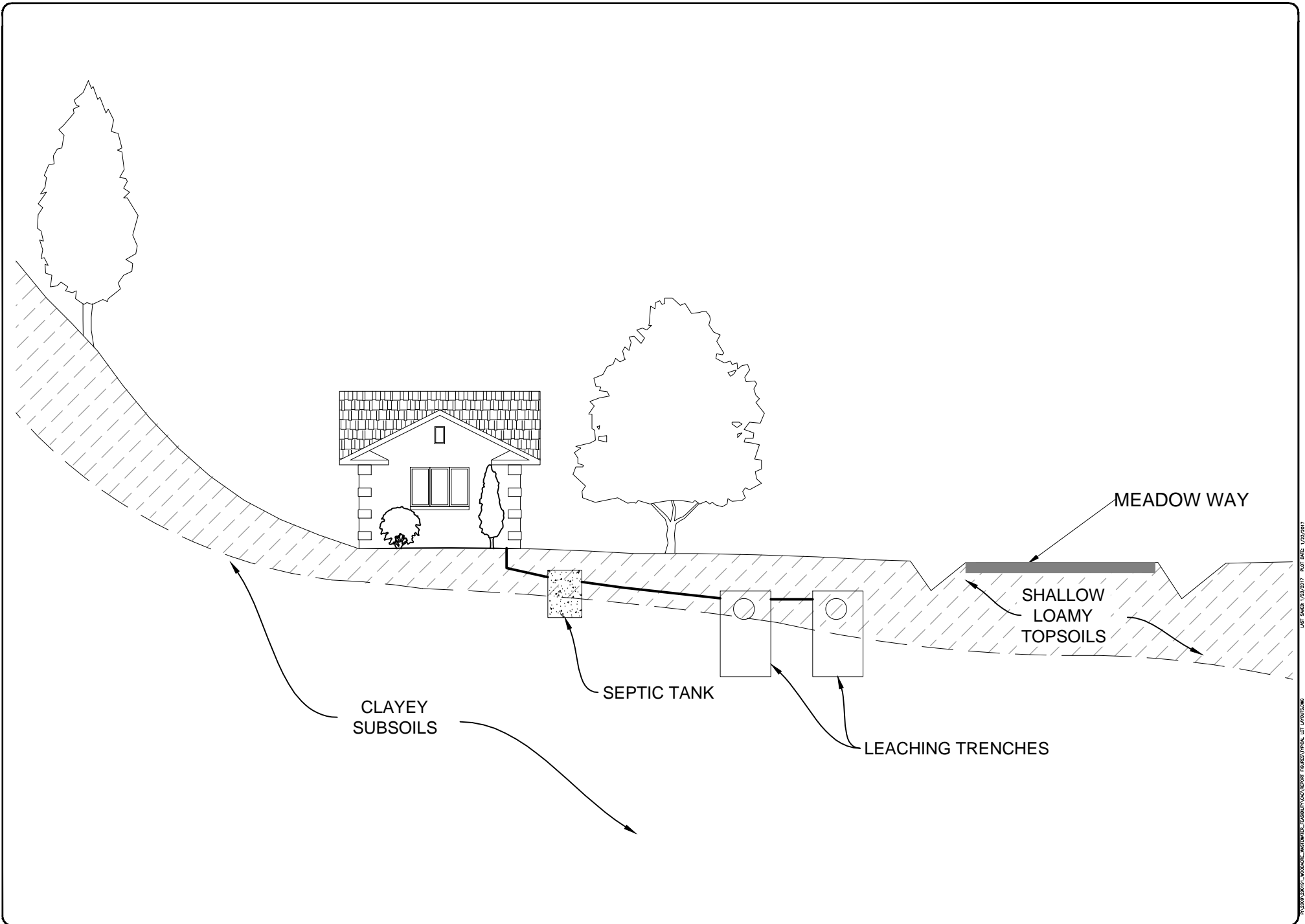

DATE PAVED 1/23/2017 PROF DATE 1/23/2017

Sl#	Rev	Date	By	Description	App'd

Design: NH/MW  
Drawn: DJ  
Checked: MW  
Appr'd: NH

**TYPICAL ONSITE CONDITIONS  
MEADOW WAY  
SLOPED SITES**

**FIGURE  
3-3**

**Table 3-1** presents a summary of the key findings as reported by Treinen (2008) for the County as a whole. A copy of the full report can be found in the 2011 *Woodacre Flats Wastewater Feasibility Study*. In the Woodacre and San Geronimo areas, Rosefield and Treinen encountered most of the problem conditions and issues noted in **Table 3-1**. In particular, they found many cases of marginal soils, high groundwater conditions, old and undocumented systems, gray water discharges, and a preponderance of small, “overdeveloped” lots, with minimal area provided for adequate onsite wastewater disposal. **Table 3-2** summarizes the information generated from the voluntary septic system inspections in Woodacre and San Geronimo. Overall, the Rosefield/Treinen surveys showed marginal to unacceptable operating conditions for about half to two-thirds of the septic systems inspected in these areas.



**Table 3-1. Summary of Septic System Inspection Findings, Septic Matters Program\***

Issue	Findings and Observations
<b>1. System Age</b>	Most systems estimated to be 30-50 years old. Many owners noted repairs had been done, most often without permits.
<b>2. Small Parcels</b>	In general, lot sizes were small, often ranging from 8,000 to 15,000 square feet. Many lots often overdeveloped with homes, garages, driveways, decks, pools and other hardscape, with limited space allowed for the septic system.
<b>3. High Groundwater (GW)</b>	Valley floor and flatter areas (such as Railroad Avenue in Woodacre) tend to have high seasonal GW, observed as high as 4 inches, and commonly 16-18 inches; pose flooding threat for septic tanks and leachfields that may be 3 to 6-feet deep.
<b>4. Small Systems</b>	Many systems smaller or substantially smaller than required under today's more scientifically based standards. Can contribute to faster accumulation of clogging bio-mat, reduced system lifespan and greater potential for hydraulic overload.
<b>5. Marginal or Shallow Soils</b>	Soils in many areas shallow or with marginal percolation, poorly suited for gravity systems, which is most commonly in use.
<b>6. Additional Living Units</b>	Secondary living units observed at 10-20% of the residences inspected, some existing without permits. This increases wastewater volume and stresses on existing systems.
<b>7. Proximity to Waterways</b>	Many systems closer to waterways than permitted by current code, with increased potential for contaminant transmission.
<b>8. Graywater Discharges</b>	Many homes found to have separate graywater discharges (laundry, showers, sinks) to the ground surface, ditches, or to unpermitted gravel filled sumps. This is done to relieve pressure on marginal or failing septic systems or occasionally by owners pro-actively reducing the load on their systems.
<b>9. Limited or No Fail Safe Area</b>	Most properties have limited or no system replacement area, especially if current set backs from wells, waterways and structures were to be enforced.
<b>10. Restricted Access to Tanks</b>	Development such as decks and pavement stones restrict some tanks for pumping and diagnosis; may contribute to less frequent or no pumping and diagnostic checks of those tanks.
<b>11. Mosquito Breeding</b>	Mosquito breeding noted in tanks and pump tanks with inadequate or poorly fitting concrete, fiberglass or wooden lids.
<b>12. Unpermitted Repairs</b>	High percentage of repairs (Kit Rosefield estimated 60%) have been made without permits, leading to questions of the adequacy of repair work and the maintenance of reasonable setbacks.
<b>13. Pre-code Tanks</b>	Some sub-standard septic tanks found, including redwood construction and bottomless tanks (e.g. function like cesspools).
<b>14. Types of Repairs</b>	Most common type of repair has been standard gravity leach lines, not necessarily suited to the soil and other site constraints. Some instances of non-standard systems, such as bottomless sand filters, mounds or advanced treatment units with subsurface drip dispersal (usually on steeper slopes). Non-standard systems generally appeared to be functioning properly and more appropriate for the observed site constraints. Non-standard repairs generally not favored by homeowners due to higher costs and large amount of space required; typically installed in connection with real estate transfer, refinancing, or home remodeling project.

\*Trienen, 2008

**Table 3-2. “Septic Matters” Inspection Results for Woodacre & San Geronimo\***

Category	Septic System Evaluation Factors	Results	
		# of Systems	% of Systems Inspected
<b>Overall Status &amp; Site Conditions</b>	<b>Total systems inspected</b>	<b>70</b>	<b>-</b>
	Systems < 100 feet from a watercourse	63	90%
	Systems with “satisfactory” or “good” overall rating	23	33%
	Systems exhibiting one or more problem conditions	46	66%
	Systems exhibiting high groundwater conditions	15	21%
	Systems incorporating alternative treatment/dispersal	9	13%
<b>Septic Tank Status</b>	Acceptable	40	57%
	Unacceptable	18	26%
	Unknown/ not Accessible	12	17%
<b>Disposal System Status</b>	Acceptable	37	53%
	Unacceptable	22	31%
	Unknown/ not Accessible	12	17%
<b>Hydraulic Load Test Results</b>	Good or Excellent	26	37%
	Satisfactory or Marginal	8	11%
	Poor or Failing	29	41%
	Unknown/Not Accessible	7	10%

\*2004/05 and 2007/08

## PERMIT FILE REVIEWS

As part of the 2011 wastewater study, Questa Engineering with assistance of Marin County EHS staff researched and reviewed septic system and related parcel information on file with Marin County for approximately 150 properties within the Woodacre Flats area. For the current study, additional permit file reviews were completed to encompass the additional 200+ properties added to the study area in Woodacre and San Geronimo. System permits, design drawings, correspondence and other file information were reviewed to determine the date of installation or of last repair, the technology or components of each system, compliance with County codes, and size of the residence or facility served. Out of approximately 360 developed properties in the Study Area permit files were found for 174 parcels (about half the total), including 108 in Woodacre and 66 in San Geronimo. **Figures 3-4** and **3-5** show, respectively, the location of the properties in the Woodacre and San Geronimo portions of the study area for which septic system records were found and reviewed. **Figure 3-4** also shows the locations of other properties in the Woodacre Flats area where field reviews were conducted as part of the 2011 wastewater study (see subsequent discussion in this section).

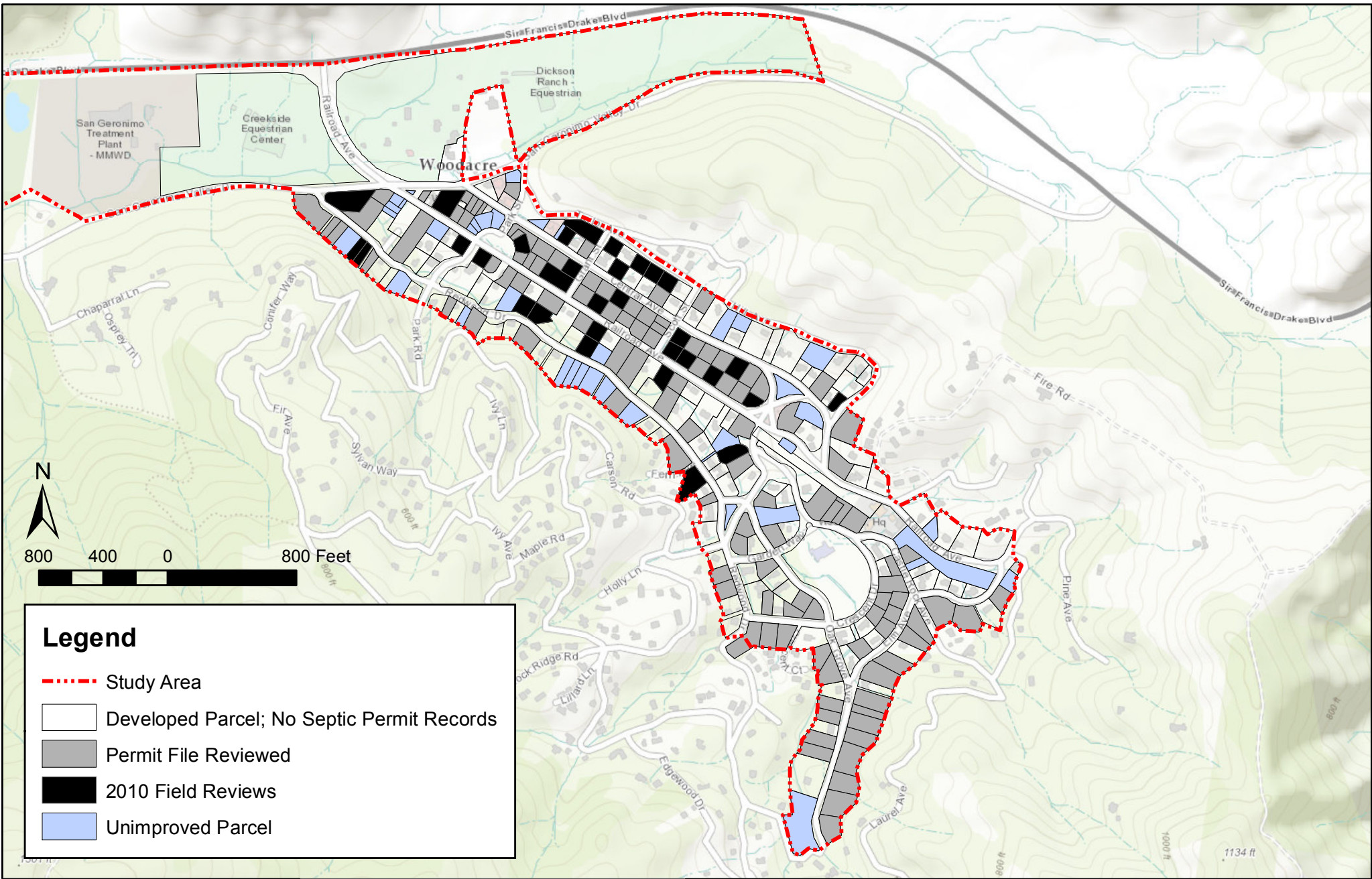

DATE:	12/12/2016
PROJECT:	WOODACRE WW
PROJECT NO.:	1600073
DRAWN:	DD
APPROVED:	NH



**WOODACRE  
SEPTIC SYSTEM PERMIT  
AND FIELD REVIEWS**

**FIGURE  
3-4**

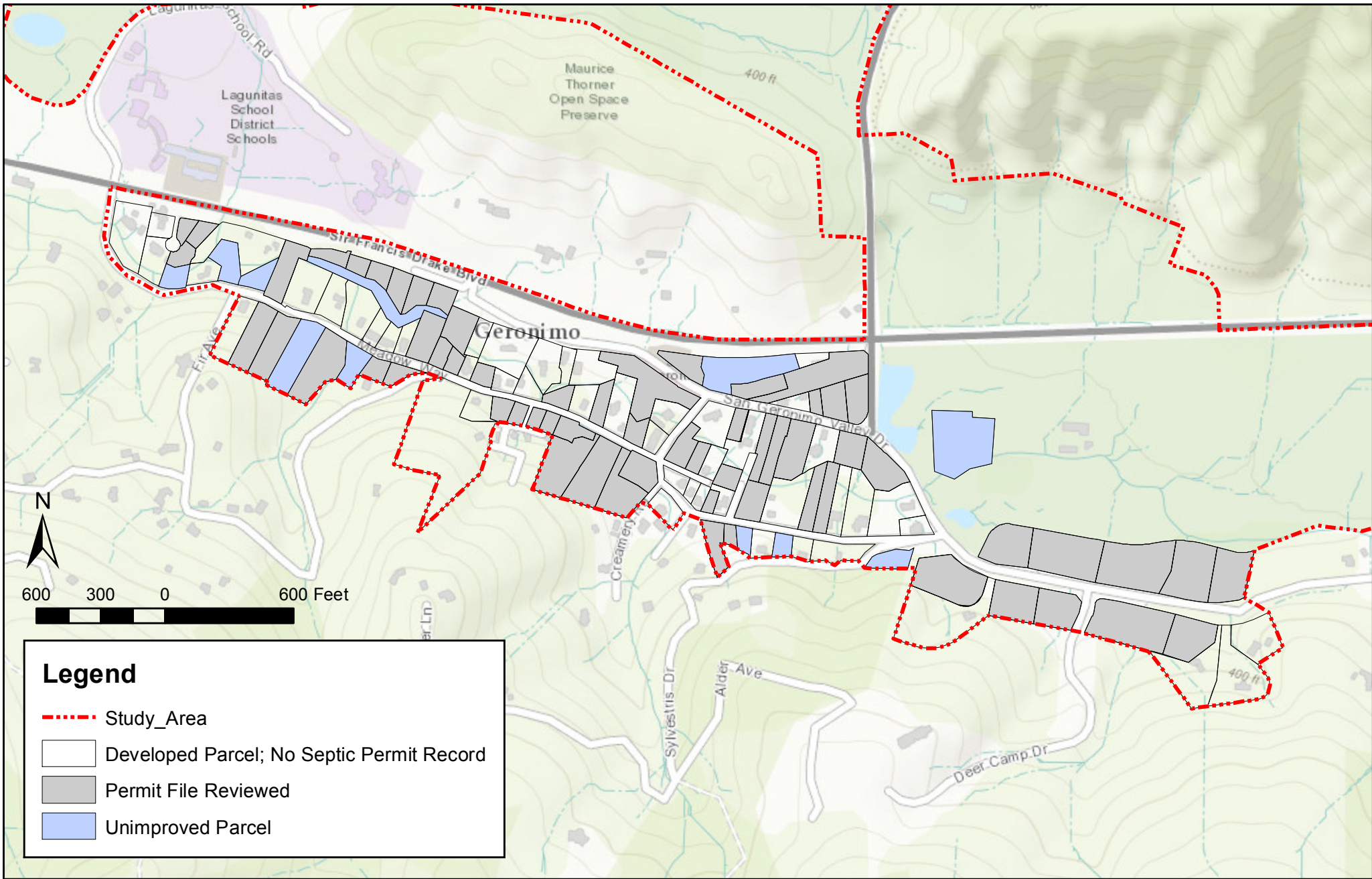

DATE:	12/20/2016
PROJECT:	WOODACRE WW
PROJECT NO.:	1600073
DRAWN:	DD
APPROVED:	NH



**SAN GERONIMO  
SEPTIC SYSTEM  
PERMIT REVIEWS**

**FIGURE  
3-5**

Information regarding the age of septic systems and an indication of new and repair system permitting work is summarized in **Table 3-3**, showing data for Woodacre and San Geronimo areas separately as well as the combined totals for entire study area. The data show the following:

- **Repairs.** The permit data show about 56% of the septic systems permit work in Woodacre (60 of 108) has been for system repairs, compared with about 30% in San Geronimo.
- **System Age.** The permit data show generally a greater proportion of septic systems being more than 30 years old in San Geronimo (77%) as compared with Woodacre (48%), which reflects a greater amount of repair activity in Woodacre in the past 30 years. Overall, nearly 60% of the septic systems for the 50% of properties for which permit information is available in the study area are more than 30 years old. A high percentage of septic systems for those properties without permit information are also likely more than 30 years old.
- **Prevailing Code.** Permit information indicates about 40 percent of the septic systems (new and repair) were constructed under the County septic regulations that underwent major update in 1984; the remaining 60 percent (with permit information) occurred under previous regulation. A high percentage of septic systems for those properties without permit information were likely not installed in accordance with current (1984) regulations.

**Table 3-3. Septic System and Installation Permitting Summary**

Age Grouping (years in service)	Original Installation	Repair System	Total # of Systems	Percent of Total Systems
<b>Woodacre</b>				
<10	3	7	10	9%
11-25	10	15	25	23%
26-30	9	12	21	19%
>30	26	26	52	48%
<b>Total</b>	<b>48</b>	<b>60</b>	<b>108</b>	-
<b>San Geronimo</b>				
<10	0	0	0	0%
11-25	3	6	9	14%
26-30	4	2	6	9%
>30	39	12	51	77%
<b>Total</b>	<b>46</b>	<b>20</b>	<b>66</b>	-
<b>Combined Woodacre and San Geronimo</b>				
<10	3	7	10	6%
11-25	13	21	34	20%
26-30	13	14	27	16%
>30	65	38	103	59%
<b>Total</b>	<b>94</b>	<b>80</b>	<b>174</b>	-

**Table 3-4** summarizes the wide range in the types and number of septic system technologies and designs used in the Woodacre and San Geronimo areas as determined from review of permit information. About 75% of systems are standard gravity-fed leachfields and seepage pits/beds. About 20% consist of alternative treatment/disposal systems and 5% are unknown from permit data. Additionally, the remaining (approximately half of total) septic systems for properties in the study where permit files are lacking would fall in the category “unknown”, but likely consist of some type of gravity leachfield or seepage pit.

**Table 3-4. Types of Onsite Wastewater Systems in Use**

System Type		Number of Systems		
		Woodacre	San Geronimo	Total
Gravity Leachfield		56	46	102
Seepage Pit/Seepage Bed		20	7	27
Alternative Systems	Mound System	8	3	11
	Pressure Distribution (PD) Leachfield	8	4	12
	Sand Filter/PD Leachfield	3	3	6
	Open Bottom Sand Filter	2	-	2
	PD Sand Trenches	1	-	1
	Supplemental Treatment w/PD Leachfield	2	-	2
	Supplemental Treatment & Drip Dispersal	-	1	1
Unknown		8	2	10
Total		108	66	174

## ONSITE FIELD REVIEWS

As part of the 2011 wastewater study, field reviews were conducted by Questa for 33 properties in the Woodacre Flats area to assess the conditions and options for upgrading existing septic systems to an acceptable repair standard. The following briefly summarizes the work and findings from these onsite field reviews. Additional details can be found in the 2011 *Woodacre Flats Wastewater Feasibility Study*.

The field reviews were arranged (voluntarily) with willing property owners to make site-specific assessments of constraints and options for onsite system repair and upgrade on a representative number of properties in the study area. As previously noted, the parcels where field reviews were conducted are indicated in **Figure 3-4**.

The field reviews involved mapping and measuring various property features along with hand-auger borings for soil/groundwater observations. From this, an assessment was made of the apparent available area for onsite septic system upgrade on each parcel, and to identify and evaluate some of the main construction issues and constraints that would be involved with the implementation of onsite system upgrades. Aerial photos and Assessor Parcel Maps were used in some cases to supplement field observations regarding property size, boundaries between parcels, and setbacks to various landscape features.

The results from the field reviews along with other background information on existing conditions and practices provided the basis for evaluating the feasibility and requirements for the onsite system upgrade and management program under consideration as an alternative in the 2011 study. Based on 33 properties reviewed, the results indicated the following categories of expected septic system upgrade, with respective percentages in each category noted:

- **Low Level** – This was assigned to properties having an existing Class 1 or Class 2 code system, where little or no repair or upgrade work would be anticipated. This included properties with mound systems, sand filters and pressure distribution leachfields, mostly permitted and installed within the last 10 to 15 years. Upgrade work for these situations might include repair or replacement of various mechanical and electrical components and possibly drainage mitigation work. It would not include major changes to the existing system. (15% of properties)
- **Moderate Level** – This was assigned to properties having sufficient area and reasonably good soil and groundwater conditions that could accommodate relatively straight forward upgrades to either the treatment or disposal system, such as: (a) addition of a supplemental treatment unit along with drainage mitigation measures; or (b) expansion of disposal capacity with shallow pressure distribution trenches along with drainage mitigation measures. (12% of properties)
- **High Level** - This was assigned to properties having severe space limitations along with shallow soil/high groundwater conditions and/or drainage setback constraints requiring considerable work to implement a satisfactory onsite upgrade/repair. The type of upgrade/repair likely to be required for most of these situations would include: (a) supplemental/advanced treatment unit, often with UV disinfection; (b) drip dispersal, often with imported soil cover fill or raised beds; and (c) surface and subsurface drainage mitigation measures. Variances to standard setback requirements would be required for most properties in this category. (73% of properties)

Additional onsite field reviews were not conducted as part of the current wastewater study for the expanded number of properties in Woodacre and San Geronimo study area. However, based on prevailing site conditions and review of permit information, the findings regarding the expected level of septic system upgrade requirements cited above were deemed a reasonable basis for estimating onsite system upgrade feasibility factors for the expanded study area.

## **LARGE-FLOW ONSITE WASTEWATER SYSTEMS**

There is one “large-flow” onsite wastewater system within the Study Area, which is the system serving the golf course clubhouse. The term “large-flow” onsite wastewater systems is generally applied to systems with design flows of 1,500 gpd or more. The existing Clubhouse wastewater system consists of a series of four (4) 1,500-gallon septic tanks, followed by a diversion valve and two leachfields of 2,700 and 1,800 lineal feet of 30-inch deep trenches, respectively. County records indicate the system was originally permitted and installed in 1965. The wastewater system was inspected and evaluated in 2009 and 2018 and found to be functional, but in need of maintenance and some repair work. It was noted at the time of the 2018 inspection that the system had not been operating to full capacity. It was recommended that the system be re-evaluated after a few months of full operation.

County records also contain plans (prepared but not implemented) for a major upgrade of the Clubhouse wastewater system in 2005. The plans included installation of additional septic tank capacity, pumping facilities and a series of three mound disposal beds, to be located in the “rough” area between the #1 and #9 fairways. The upgrade, designed for a flow of 6,000 gpd, was intended to bring the facility into compliance with current standards at the time when building improvements were being considered for the golf course.

Also, although not located within the Woodacre-San Geronimo study area, there are a few existing large-flow, community-type wastewater systems providing onsite wastewater treatment and disposal for development on properties bordering or near the study area (**Figure 3-6**). None of these systems produce recycled water or have any plans to do so. These wastewater systems, which employ advanced/secondary treatment and onsite subsurface disposal using pressure distribution and/or drip dispersal methods, include the following:

- **Spirit Rock Meditation Center.** 7,500 gpd AdvanTex recirculating textile filter with multiple pressure distribution leachfields and drip dispersal fields for residences, overnight retreats, and day use activities.
- **Lagunitas School.** 10,000 gpd recirculating sand filter and dual, pressure distribution leachfields serving approximately 400 students and staff.
- **French Ranch Development.** 11,200 gpd recirculating sand filter and dual, pressure distribution leachfields for up to 32 single-family residences (29 presently developed).

These systems are regulated under waste discharge requirements issued by the Regional Water Board and operating permits issued by the Marin County EHS.



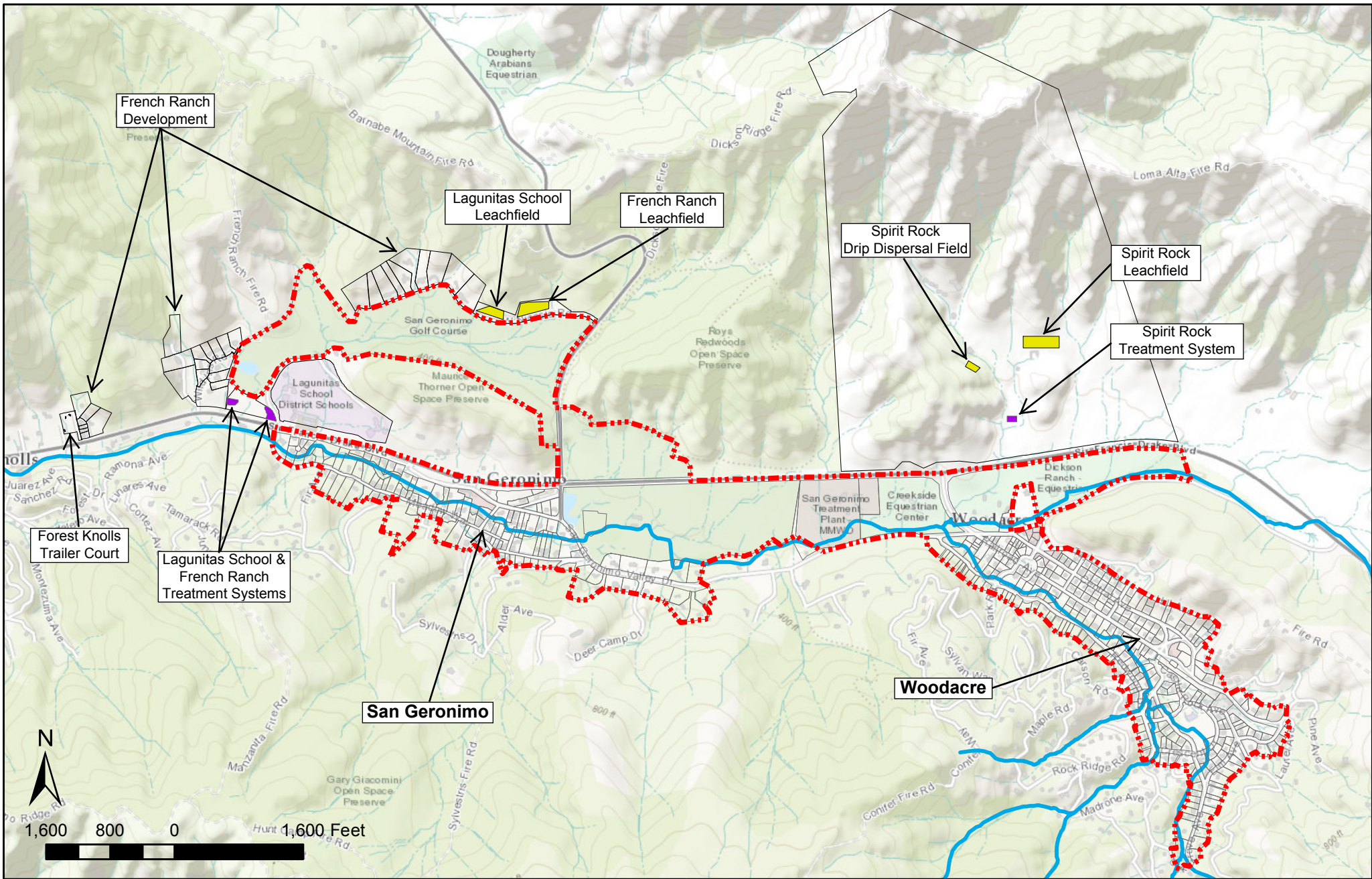

DATE:	12/20/2016
PROJECT:	WOODACRE WW
PROJECT NO.:	1600073
DRAWN:	DD
APPROVED:	NH



**NEARBY LARGE-FLOW  
WASTEWATER SYSTEMS**

**FIGURE  
3-6**

## **SECTION 4: SERVICE AREA CHARACTERISTICS**

### **SERVICE AREA**

Wastewater improvement projects are planned and developed around a given geographical area termed the “service area”. The service area provides the basis for estimating wastewater facility requirements, project alternatives and costs. Delineating the service area is often an iterative process, whereby initial boundaries are assumed for feasibility analysis, and subsequently adjusted in response to findings, recommendations and other factors. **Figure 4-1** shows the Woodacre-San Geronimo study area and service area considerations discussed below.

### **2011 Woodacre Flats Study**

The 2011 Wastewater Feasibility Study for Woodacre Flats addressed a service area encompassing approximately 150 mostly residential parcels in the low-lying portions of the community of Woodacre. Out of the study came the identification of a wastewater recycling alternative centered around the San Geronimo Golf Course that could potentially support a larger service area, which was favorably received by the community.

### **Woodacre-San Geronimo Service Areas**

The current study was undertaken to evaluate the feasibility of a community wastewater system to serve a larger study area, including additional homes in Woodacre Flats plus homes in a portion of San Geronimo located in similar valley areas near the Golf Course. The study area encompasses developed properties believed to be in most need of wastewater improvements and where residents have expressed the greatest level of interest in studying possible sewerage alternatives. There are a total of approximately 360 developed parcels within the larger Study Area, with about two-thirds in Woodacre and one-third in San Geronimo.

The approach to this project does not anticipate a condition or requirement for mandatory connection to community wastewater facilities for all properties in the Study Area or for any particular properties. It does, however, include the limitation that the facilities be planned and implemented to serve existing developed properties, with allowance for a modest amount of expansion for low-incoming housing, child day care facilities or similar community needs.

There is varied property owner interest in connection to community wastewater facilities, as well as differing wastewater improvement needs from property to property. Although not the most economically efficient, the types of wastewater collection systems evaluated for the project lend themselves to providing service to a mix of “connected” and “non-connected” properties along the sewer route.

Based on the above, feasible project alternatives were formulated with different configurations and capacities to serve all or portions of the 360 developed properties in the Study Area as discussed further in the description of alternatives and estimation of wastewater flows.

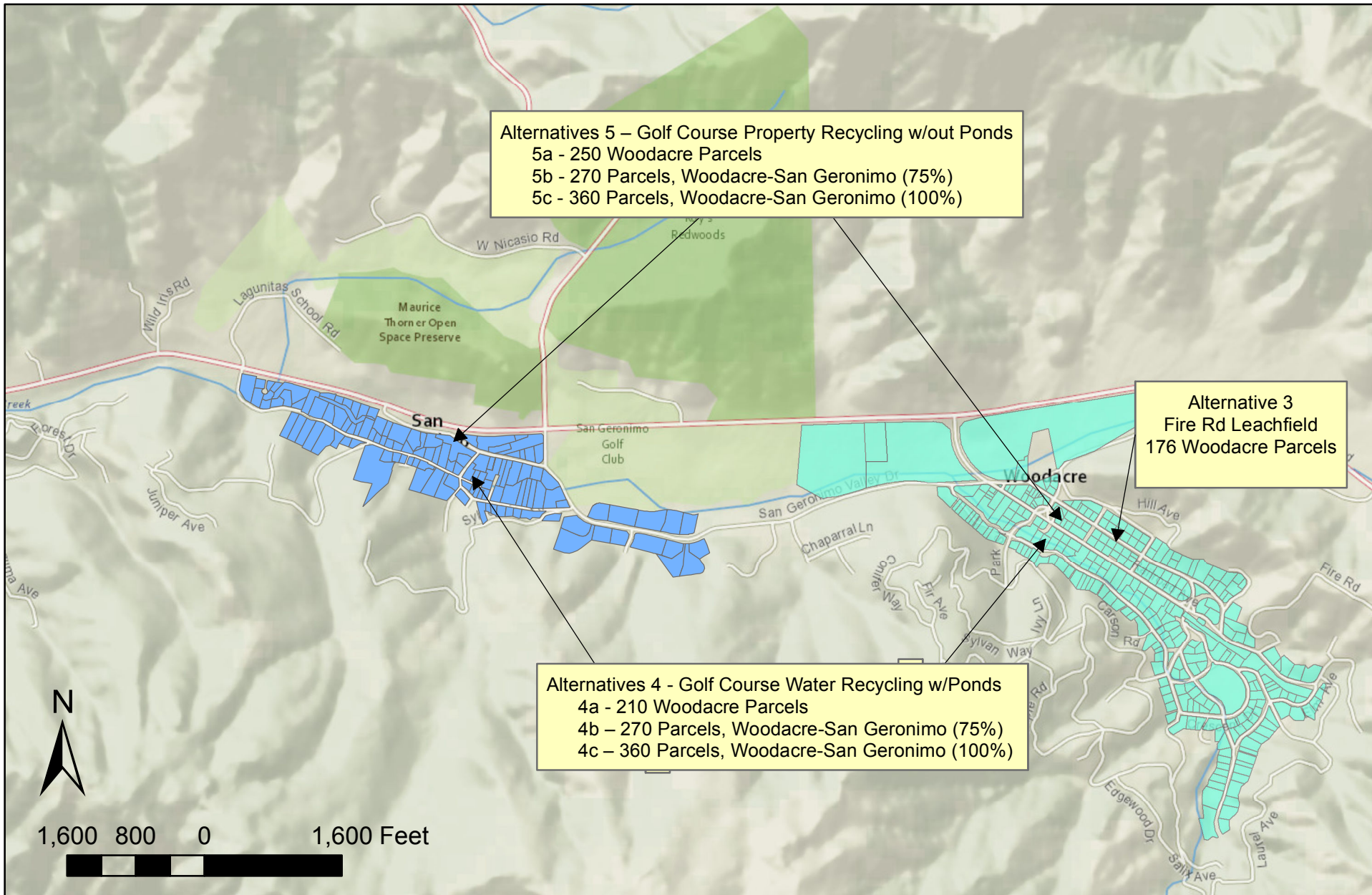

DATE:	2/20/2019
PROJECT:	WOODACRE WW
PROJECT NO:	1600073
DRAWN:	MF
APPROVED:	NH



# SERVICE AREAS

**FIGURE  
4-1**

## **ESTIMATED WASTEWATER FLOWS**

### **Wastewater Flow Factors**

Information regarding wastewater is important in the assessment of required capacity of collection, treatment, storage and disposal facilities for community wastewater systems.

- Collection system design requires consideration of peak flow conditions during the day, which may include infiltration and inflow, particularly for conventional gravity sewers.
- Wastewater treatment system design is based primarily on average daily flow, with hydraulic capacity for peak flows; fluctuations from day to day and during the day are normally addressed with flow equalization facilities.
- Wastewater storage facilities, such as wet weather storage ponds, are designed on the basis of average monthly wastewater flows.
- Land application-disposal facilities design varies depending on the method used. For example, leachfields that operate continuously throughout the year must be designed to handle peak flows during the period of maximum occupancy, usually determined on a weekly basis, and may be moderated by incorporation of flow equalization. Systems using irrigation for wastewater disposal/recycling are designed to regulate the daily discharge using storage reservoirs or the like, with the discharge matched to the vegetation requirements, soils and climatic conditions; the accumulated flow on a monthly or seasonal basis is typically the determining factor for irrigation systems.

Sewer systems are subject to infiltration of groundwater and inflow of surface water through joints and cracks in pipes and manholes. The amount of infiltration/inflow (I/I) depends on the groundwater and drainage conditions, the age and condition of the sewers, and the type of sewer design. Older sewers are most notorious for experiencing high amounts of I/I; in the worst cases the I/I component may equal or exceed the sewage component. However, in newer installations I/I is more typically maintained below 10% of the sewage flow, and may be essentially nil for pressure sewer and effluent (STEP) systems that don't include manholes, utilize more shallow pipe installation and tightly sealed (or heat-fused) pressure pipe connections. Portions of the service area, especially Woodacre Flats, experience high groundwater conditions that must be accounted for where gravity sewers are used. However, overall the recommended collection systems in all community wastewater alternatives includes substantial use of pressure sewers, and should result in a relatively low I/I contribution. We included a 25% I/I factor as a reasonable allowance for peak wet weather flow estimates to be on the safe side.

### **Unit Wastewater Flows**

Estimated wastewater flows for the study were developed based on the assumed number of parcels to be served, the type of development on the those parcels, and review of typical reference data and monitoring information from other small community wastewater facilities.

Unit wastewater flows in gallons per day (gpd) per single family residence (or equivalent) were developed from review of daily and monthly flow data for a recent six-year period for three small community wastewater systems: (1) French Ranch development, (2) Marshall Community Wastewater Facility, and (3) Lake Canyon Community Services District near Los Gatos in Santa Clara County. The wastewater flow information for these three facilities is summarized in **Table 4-1**, including average annual and average winter unit flows, expressed as gallons per day (gpd) per residential parcel.

**Table 4-1. Unit Flow Reference Data for Community Wastewater Facilities<sup>1</sup>**

Community System	Number of Parcels	Years of Operation	Annual Ave. Daily Flow (gpd/parcel)	Winter Ave. Daily Flow (gpd/parcel)	Notes
Lake Canyon CSD (Santa Clara Co.)	51	19	58	57	Old homes; effluent (STEP) collection system to community leachfield
French Ranch (Marin Co.)	28	15	121	140	New subdivision with gravity sewers; peak flows affected by rainfall inflow to sand filter bed
Marshall Phase 1 (Marin Co.)	32	8	79	80	Old homes; some rental and seasonal occupancies; effluent (STEP) sewers to community leachfield

<sup>1</sup> Source: Self-Monitoring Reports on file with RWQCB; average flows for 2009-2015

Taking into account the data in **Table 4-1** and an allowance for infiltration/inflow (I/I) as discussed above, the following estimated unit wastewater flows were selected for assessing community wastewater alternatives. **Figure 4-2** provides a graphical plot of the comparative data and proposed assumptions.

- 30-day Average Daily Flow, Wet Weather: 120 gpd/parcel
- 30-day Average Daily Flow, Dry Season: 100 gpd/parcel
- Peak Daily Flow Wet Weather: 150 to 170 gpd/parcel

## Estimated Wastewater Flows for Project Alternatives

Woodacre and San Geronimo service areas consist mainly of single family residential parcels, with a small amount of commercial uses. The commercial uses are mainly the types that generate wastewater volumes similar to or less than single family residences (e.g., offices, shops, Post Office, small apartments). The noted exceptions are two commercial uses: (1) Two Bird Café, a small restaurant; and (2) the San Geronimo Golf Course Clubhouse, which includes a restaurant, bar and banquet facilities in addition to restroom use for employees and golfers. The estimation of wastewater flows were developed by applying the above unit wastewater flow assumptions for residential and small commercial properties, with an added allowance for the Two Bird Café and Golf Course Clubhouse based their respective food service activities and

**Figure 4-2.**  
**Unit Wastewater Flow Comparisons**

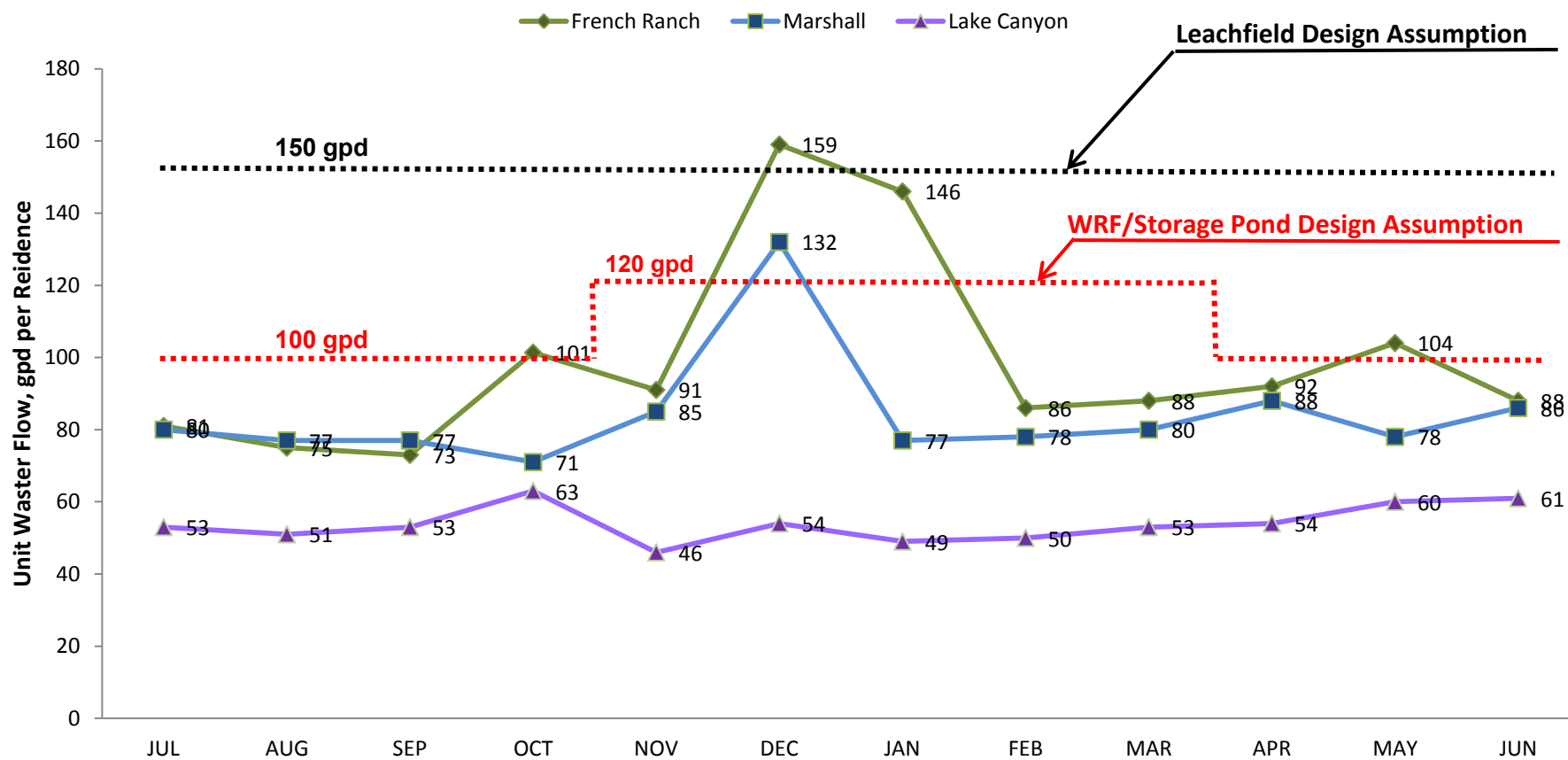

higher volume of wastewater generation. The resulting wastewater flow estimates for the different project alternatives are presented in **Table 4-2**.

**Table 4-2. Estimated Wastewater Flows, gpd**

Community Wastewater Alternative		ESDs <sup>1</sup>	Unit Wastewater Flows, gpd		Estimated Wastewater Flow (gpd)
			Per ESD <sup>1</sup>	Clubhouse	
3	Fire Road Community Leachfield	176			
	▪ Ave Wet Weather		150	-	26,400
	▪ Ave Dry Weather		150	-	26,400
	▪ Peak Daily Flow		170	-	30,000
4a	Woodacre Only	210			
	▪ Ave Wet Weather		120	800	26,000
	▪ Ave Dry Weather		100	1,000	22,000
	▪ Peak Daily Flow <sup>2</sup>		-	-	35,000
5a	Woodacre Only	250			
	▪ Ave Wet Weather		120	800	30,800
	▪ Ave Dry Weather		100	1,000	26,000
	▪ Peak Daily Flow <sup>2</sup>		-	-	40,000
4b & 5b	Partial (75%) Woodacre-San Geronimo	270			
	▪ Ave Wet Weather		120	800	33,200
	▪ Ave Dry Weather		100	1,000	28,000
	▪ Peak Daily Flow <sup>2</sup>		-	-	45,000
4c & 5c	Full Woodacre-San Geronimo	360			
	▪ Ave Wet Weather		120	800	44,000
	▪ Ave Dry Weather		100	1,000	37,000
	▪ Peak Daily Flow <sup>2</sup>		-	-	60,000

<sup>1</sup> ESD stands for Equivalent Single-family Dwelling.

<sup>2</sup> Peak daily flow estimated at 1.3 times wet weather flow, rounded.

## WATER RECYCLING USES

### Existing Water Recycling

There are no existing uses of recycled water in the San Geronimo Valley project area and no existing or planned sources of supply within a reasonable distance. The two existing water recycling operations in Marin County, both about 15 to 20 miles from the project area, are: (1) the Las Gallinas Valley Water Recycling Facility, operated by MMWD and Las Gallinas Valley Sanitary District; and (2) the Novato Recycled Water Program, a collaboration between North Marin Water District and Novato Sanitary District. These programs supply recycled water primarily for turf and landscape irrigation at golf courses, schools, parks, cemeteries and large landscaped areas on commercial and public sites generally along the Highway 101 corridor between San Rafael and Novato. They also provide recycled water for pasture irrigation and wetland enhancement projects along the nearby baylands.

## Potential Water Recycling Uses

**San Geronimo Golf Course Irrigation.** At the initiation of this study, turf irrigation at the San Geronimo Golf Course was the largest and most logical site in the project area for potential use of recycled water. Irrigation water for the golf course consisted principally of water supplied from the MMWD raw water pipeline along Sir Francis Drake Boulevard. The irrigation demand for the golf course ranged historically from about 46 to 53 million gallons per year (140 to 160 acre-feet per year), depending on seasonal weather conditions, with peak daily use as high as 200,000 to 300,000 gallons at certain times of the year. At 2018 MMWD water rates, the cost of 150 acre-feet per year would be approximately \$276,000.

**Potential Future Irrigation on Golf Course Property.** With the sale of the golf course property in 2017 the continued operation of the golf course is now uncertain. If the golf course use does not remain, there is the potential that significant portions of the property may be converted to park, open space and habitat restoration, while retaining some public, community and visitor serving uses on the parcel containing the existing clubhouse building and facilities (“Clubhouse Parcel”). Even though the redevelopment plans for the property are unknown, given the extent of land, existing conditions and general range of potential uses, there are likely to be significant needs for irrigation water, which could be provided either from the existing MMWD raw pipeline or from a recycled water project. Potential recycled water uses may include the following:

- **Landscape Irrigation on Clubhouse Parcel.** Currently there are about 12 acres of irrigated landscaping and golf course turf grass on the Clubhouse Parcel. It is anticipated that significant landscaping will be part of the future plans for this parcel, whether for shrubbery, trees or turf grass, all of which could be irrigated with tertiary treated recycled water. As a rule of thumb, seasonal irrigation demand for turf grass and landscaping in the San Geronimo project area would be about 4,000 gpd per acre.
- **Park, Open Space and Environmental Restoration Irrigation.** Conversion of the golf course area to park, open space or habitat restoration would require some level of irrigation that could be supplied from tertiary treated recycled water. This could include, for example: (a) areas of maintained turf grass (e.g. playfields, picnic areas, fire zone buffers); (b) trees or other vegetation dependent on irrigation, such as existing redwoods benefiting from historical irrigation of the adjacent golf course turf; and (c) special habitat restoration features, such as wet meadows requiring a dependable supply of supplemental water for seasonal saturation.
- **Nursery or Greenhouse Facility.** A specialty nursery or greenhouse (e.g., for native plants), if included in future development plans, could be a candidate for use of recycled water. Daily water demand for nurseries and greenhouses is typically greater than for outdoor landscaping, depending on the type of plants, and can have an extended growing season and irrigation demand through the winter months.
- **Temporary Irrigation for Plant Establishment.** Temporary irrigation of restoration plantings would likely be required for a few to several years during the initial plant establishment period, regardless of long-term irrigation requirements. If restoration work is carried out over a multi-year period, this would extend the period of time requiring temporary irrigation water, which could be supplied by recycled water.



**Other Nearby Irrigation Uses.** There is the potential for significant irrigation of nearby playfields and landscaping at the Lagunitas Elementary School, located about 1 mile west of the San Geronimo Golf Course property on Sir Francis Drake Boulevard. The school property has about 5 acres irrigated of landscaping and turf grass that could potentially be converted to use recycled water. The cost of installing a new pipeline along Sir Francis Drake Boulevard (several hundred thousand dollars) would likely render the school's use of recycled water infeasible. However, since the school borders the golf course property along current golf hole #12, using the existing golf course irrigation piping as an intertie could potentially make it economically viable to deliver recycled water to the school.

**Potential Trucked Water Markets;**

Inclusion of a tap or other means of tanker-truck fill-up with recycled water could be included in a recycled water facility for the project. Potential uses include the following:

**Construction Water.** Grading and earthwork associated with construction requires water for dust control, soil compaction, vehicle cleaning, etc.

**Sewer Cleaning.** Recycled water (minimum disinfected secondary treated) may be used for sewer cleaning (e.g., flushing). This is typically done by tanker-trucks equipped with high capacity power flushing equipment. Sewer cleaning is conducted year-round and performed on an annual basis in some municipal systems, such as the Ross Valley Sanitary District, the nearest municipal system in the project vicinity. This represents a potential future opportunity for use of recycled water from the project, especially during the wet weather season when irrigation water demands on the golf course property would be minimal or absent.

**Fire Suppression.** Tertiary treated water can be used for firefighting. This would be a potential recycled water use that although incidental and occasional, would provide an emergency reservoir of water. If the existing County Fire Department facility in Woodacre were to be re-located to the San Geronimo Golf Course property, the uses of recycled water for fire suppression, vehicle/equipment washing, and dual plumbing of the firehouse could be significant.

**Toilet Flushing in Public Restrooms.** Disinfected tertiary treated water can be recycled for toilet flushing in public restrooms. Currently there are no public restrooms in the project vicinity with sufficient use and/or properly equipped to support this recycled water use. However, if the future uses of the golf course were to include new public restroom(s), e.g., in connection with park facilities or a roadside rest stop, it would be logical to incorporate plumbing to allow use of recycled water for toilet flushing. Also, if substantial remodeling of the existing clubhouse building were to occur in the future, there could be an opportunity to install dual plumbing to allow use of recycled water for toilet flushing.

## **SECTION 5: WASTE DISCHARGE AND RECYCLING REGULATORY REQUIREMENTS**

### **ONSITE WASTEWATER TREATMENT SYSTEMS (OWTS)**

Criteria governing the siting and design of onsite wastewater treatment systems (OWTS) in the project area are contained in Marin County Code Chapters 7.36 and 18 and *Marin County Regulations for Design, Construction and Repair of Individual Sewage Disposal Systems*. The Regulations have been adopted in accordance with provisions of Code Chapters 18.06 and 18.07, respectively, which govern the use of Standard OWTS and Alternative OWTS in the county. These requirements apply to OWTS having wastewater design flows of up to 10,000 gpd. Systems with flows greater than 10,000 gpd are regulated by the Regional Water Board.

Additionally, in 2012 the State Water Board adopted the *Water Quality Control Policy for the Siting, Design, Operation, and Management of Onsite Wastewater Treatment Systems*, also known as the State OWTS Policy. The State OWTS Policy sets minimum standards that go beyond the established County requirements in some instances, such as for OWTS located near public water supply wells, water supply intakes, and impaired water bodies.

Some of the key regulatory provisions contained in Marin County regulations for OWTS are reviewed here.

#### **Soil Depth**

A minimum of 3 feet of soil depth is required below the leaching trenches (or bed). The soil within and below the leaching trenches must be permeable and of a suitable texture and structure for absorption of sewage effluent. Coarse sand and gravels are unacceptable due to the lack of fine soil particles for filtration and treatment; heavy clay soils, on the other hand, are generally unsuitable due to inadequate permeability.

#### **Percolation Rates**

The percolation rate for conventional leachfields and alternative dispersal systems is required to be within the range of 1 to 120 minutes per inch (MPI). The percolation rate is used to establish an appropriate wastewater loading rate, which is then used for sizing the dispersal field.

#### **Depth to Groundwater**

The required depth to groundwater, below the bottom of the leachfield trench varies according to the percolation rate and soil characteristics and system type. For percolation rates of 5 to 60 MPI or where the soils have more than 15 percent silt plus clay fraction ("fines"), the required depth to groundwater is 3 feet (below trench bottom). A greater depth to groundwater is required for rapidly permeable soils where the soil texture lacks sufficient "fines" for treatment. For soils with a percolation rate between 1 and 4 MPI, the required depth to groundwater is 10 feet where there are 10 to 15% fines, and 20 feet where there are less than 10% fines. These depth requirements apply to disposal of septic tank effluent through conventional leaching trenches

and may be reduced (to a minimum of two feet) if additional treatment or alternative dispersal system design (e.g., mounds) are provided.

## **Setbacks from Wells and Watercourses**

Required minimum setback distances between wastewater disposal fields and various water features are as follows:

- Water wells 100 ft.
- Public water supply wells 150 ft.
- Springs 100 ft.
- Natural lake or water supply reservoir 200 ft. (from high-water line)
- Perennial watercourses 100 ft. (from top of bank)
- Seasonal streams and wetlands 75 ft. (from top of bank)
- Intermittent/ephemeral streams 50 ft. (from top of bank)
- Public water supply intakes 200 to 400 ft. from applicable water body

Marin County Regulations also specify minimum setback distances for other site features such as property lines, buildings, paved areas, cuts and embankments, and water lines. Variations in setback requirements are permitted in conjunction with certain alternative systems (e.g., sand filters), for system repairs, and under formal variance provisions.

## **Disposal System Design**

The standard disposal field design in Marin County is a trench system, 18-inches wide and ranging in depth from 2 to 8 feet. The system is sized according to the trench sidewall area and the wastewater loading rate determined from the percolation test results (see above). The design wastewater flow for a residential system is based on the number of bedrooms in the house, and a standard flow criterion of 150 gpd/bedroom, which may be reduced to 105 gpd/bedroom with the incorporation of low-flow plumbing fixtures, which has become a standard practice.

## **Dual System Capacity**

Individual wastewater disposal systems are required by Marin County Regulations to have dual fields; i.e., a primary and back-up disposal field, each with 100% capacity, that operate on an alternating basis. The purpose is to extend the life of the disposal field. Normally, in such a system the flow is alternated between leachfields every six to twelve months. In many repair situations, dual capacity (and sometimes 100% capacity) cannot be provided; in such instances the disposal system is often designed to make maximum use of available suitable area.

## **Cumulative Impact Assessment**

High-density development using OWTS and/or larger flow systems can contribute to elevated nitrogen concentrations in the groundwater and/or a general rise or mounding of the water table. County Regulations require completion of cumulative impact assessments for nitrate loading and groundwater mounding for certain OWTS, based on the size (design flow) of the wastewater system or other factors on a case-by-case basis. The results of the analysis may

be the basis for denial, modification or imposition of specific conditions for the OWTS proposal, in addition to other siting and design criteria.

## **Operations and Monitoring**

Alternative wastewater systems require monitoring of system operations, and submission of periodic reports to the County. The monitoring is intended to keep track of such things as wastewater flow rates and volumes, treatment effectiveness, disposal field performance and conditions, and downstream/downgradient water quality measurements at monitoring wells or surface drainage points. Quarterly monitoring and annual reporting requirements are typical for the first few years of system operation, decreasing to semi-annual or annual monitoring in subsequent years depending upon successful system performance.

## **Repair System Requirements**

For repair of existing septic systems, Marin County EHS attempts to achieve compliance with current regulations to the maximum extent practicable. However, full compliance with all code requirements is generally not possible. Heavy emphasis is given to case-by-case evaluation to achieve the best repair possible, considering the site limitations and environmental resources and public health issues at risk. Evaluation and approval of OWTS repairs is guided by criteria contained in the County's "Remodel & Additions Policy".

## **Impaired Water Bodies**

Several water bodies in Marin County are listed as impaired under Section 303(d) of the Federal Clean Water Act for different water quality constituents. Additional requirements may apply to OWTS located adjacent to or within the contributing watershed of impaired water bodies as a result of the provisions of the State OWTS Policy or in connection with Total Maximum Daily Load (TMDL) requirements adopted by the Regional Water Board for specific bodies.

There are no impaired water bodies within the study area. However, Woodacre Creek and San Geronimo Creek are within the watersheds of Tomales Bay and Lagunitas Creek, which are both listed as impaired. The following statutory requirements pertain to the impaired status of these water bodies:

- Tomales Bay is listed as impaired for pathogens and nitrogen. In 2005, the Regional Water Board adopted the Pathogens TMDL for Tomales Bay, which found that OWTS that discharge to land in a manner consistent with accepted design standards (for new systems) or according to specific performance standards (for existing systems) would be considered acceptable, providing that they are properly operated and maintained. The Tomales Bay TMDL for nitrogen has not been completed; it is unknown when the TMDL will be completed and whether or not the TMDL will contain any requirements applicable to OWTS located in San Geronimo Valley.
- Lagunitas Creek is listed as impaired for nitrogen, but the TMDL has not been completed. It is not known when the TMDL will be completed and whether or not it will contain any requirements applicable to OWTS located in San Geronimo Valley.

## TITLE 22 - WATER RECYCLING CRITERIA

Water quality standards and treatment reliability criteria for water recycling are set forth in Title 22, Division 4, Chapter 3 of the California Code of Regulations (Title 22). Requirements for a specific use of recycled water that are not covered by the uniform statewide criteria are established by State Water Board, Division of Drinking Water on a case-by-case basis. Uniform statewide criteria include bacteriological water quality standards, which are based on the expected degree of public contact with recycled water. Title 22 Water Recycling Criteria were last updated in June 2014 and include new requirements pertaining to use of recycled water for ground water replenishment/reuse.

### Treatment Level and Reuse Applications

For water reuse applications with a high potential for public contact with recycled water, Title 22 standards require disinfected tertiary treatment. For applications with a lower potential for public contact, Title 22 allows for secondary treatment with different levels of disinfection (bacteriological limits) depending on the particular recycling use. Allowable uses for disinfected tertiary recycled water include:

- Irrigation of food crops, including all edible root crops, where the recycled water comes into contact with the edible portion of the crop;
- Irrigation at parks and playgrounds, school yards, residential landscaping, and unrestricted access golf courses;
- Industrial cooling water that involves use of a cooling tower;
- Dust control for roads, streets, and construction sites;
- Cleaning roads, sidewalks, and outdoor work areas;
- Flushing toilets and urinals, priming drain traps, industrial process that may come in contact with workers, firefighting (structural and nonstructural), decorative fountains, commercial laundries, consolidation of backfill around potable water pipelines, and car washes; and
- Any other irrigation uses not specifically prohibited.

According to Title 22, recycled water used for unrestricted golf course and landscape irrigation must meet requirements for “disinfected tertiary recycled water”. Among other things, this requires that the wastewater must be oxidized and filtered to a tertiary level, followed by disinfection using an approved process and meets the following requirements:

- **Total Coliform.** Median concentration of total coliform bacteria measured in the disinfected effluent not exceeding a most probable number (MPN) of 2.2 per 100 mL utilizing the results of the last seven days for which analyses have been completed, not exceeding 23 MPN per 100 mL in more than one sample in any 30-day period, and no sample exceeding 240 MPN per 100 mL.

- **Turbidity.** The filtered effluent prior to disinfection and following passage through a microfiltration, ultrafiltration, nanofiltration, or reverse osmosis membrane does not exceed a turbidity of (1) 0.2 nephelometric turbidity units (NTU) more than 5 percent of the time in a 24-hr period; and (2) 0.5 NTU at any time. Turbidity shall be continuously monitored, with the capability to automatically divert the wastewater should above limits be exceeded.

Title 22 includes various provisions related to sampling and analysis to verify compliance with the above effluent quality requirements. The sampling requirements are established to assure protection of the public health because there is potential risk of human exposure to the recycled water. Standard sampling provisions normally include continuous turbidity monitoring and daily coliform sampling.

## **Reliability and Storage**

Title 22 also includes provisions for short-term emergency storage (minimum one day of design flow) and redundancy in various treatment processes to ensure continuous and reliable operation. Additionally, Title 22 requires provisions for long-term storage (minimum of 20 days) or an alternate method of disposal for periods when recycling is not possible, e.g., due to the lack of irrigation demand during rainy periods or when/if the treated effluent fails to meet bacteriological limits. Long-term storage/disposal is commonly provided by holding pond(s), but may also include alternate means for disposal such as percolation ponds, leachfields, or diversion to municipal sewer system, where available.

## **Use Area Requirements**

Title 22 contains the following requirements pertaining to the areas where tertiary recycled water would be applied:

- No application of tertiary recycled water shall occur within 50 feet of a domestic well, unless supported by a geological investigation;
- No impoundment of tertiary recycled water shall occur within 100 feet of any domestic water well;
- No runoff of irrigation water from the recycled use areas shall occur unless determined not to pose a public health threat and authorized by the regulatory agency;
- No spray, mist or runoff shall enter dwellings, designated outdoor eating areas, or food handling facilities;
- Drinking water fountains shall be protected against contact with recycled water spray, mist or runoff;
- Standard warning signs shall be posted where recycled water is uses that are accessible to the public;
- No physical connection shall be allowed between recycled water systems and potable water systems; and

- No hose bibs shall be allowed in the recycled water system in areas accessible to the public; quick couplers shall be used instead.

Project facilities and areas using recycled water would be developed and maintained to meet all of the above requirements.

## Engineering Report

Any project proposing water recycling is required to submit for review and approval to the Water Recycling Unit of the State Water Board, Division of Drinking Water (DDW), an Engineering Report in compliance with the provisions of Title 22, Section 60323 of the California Code of Regulations. This report is required to follow the document titled "Guidelines for the Preparation of an Engineering Report for the Production, Distribution, and Use of Recycled Water", issued by State Water Board, DDW. This report is normally completed prior to, or in conjunction with, the filing of a Report of Waste Discharge with the Regional Water Board.

## WASTE DISCHARGE REQUIREMENTS (WDR)

### General WDRs for Small Domestic Wastewater Systems - Order WQ 2014-0153-DWQ

Community wastewater facilities for the Woodacre-San Geronimo study area, whether they include leachfields (**Alternative 3**) or water recycling (**Alternatives 4 and 5**), would be regulated by the San Francisco Bay Regional Water Board through the issuance of Waste Discharge Requirements. Based on the size (design flow) of the facilities, the system would most probably be regulated under the State Water Board's *General Waste Discharge Requirements for Small Domestic Wastewater Systems - Order WQ 2014-0153-DWQ*. This is a general permit applicable to small, community-type wastewater systems such as the projects under study for the Woodacre-San Geronimo area. Facilities with average monthly wastewater flows of 100,000 gpd or less are eligible for coverage under this General Order. The San Francisco Bay Regional Water Quality Control Board has applied Order WQ 2014-0153-DWQ to other community wastewater projects in the region, including the Marshall Community Wastewater System in Marin County.

The provisions under Order WQ 2014-0153-DWQ cover the entire wastewater system, which is defined in the Order as including "... the collection system, treatment equipment, pumping stations, treatment ponds, clarifiers, and/media filters, disinfection systems, recycled water systems (including distribution systems), storage ponds, land application areas, and other systems associated with the collection, treatment, storage, and disposal of wastewater". The Order contains requirements for various types of wastewater treatment and disposal systems, including water recycling facilities. In addition to general provisions for water quality protection, it includes performance standards, effluent limitations, and setback criteria applicable to different treatment, storage and disposal methods. The Order incorporates directly or by reference Title 22 requirements for any water recycling facility. Attachment C of the Order provides a "Model Monitoring and Reporting Program", which sets forth the standard scope and details normally applied, with provisions for project-specific requirements assigned by the Regional Water Board as deemed necessary.

Noteworthy requirements contained in the Order pertinent to the Woodacre-San Geronimo wastewater alternatives include setbacks, effluent limitations, and wastewater pond sizing criteria.

### ***Wastewater System Setbacks***

**Table 5-1** presents the setback requirements contained in **Table 3** of the Order, including requirements applicable to various types of treatment components, leachfields and land application areas, and wastewater storage ponds that have applicability to project alternatives under consideration for Woodacre-San Geronimo. The setbacks reflect a compilation of requirements from Title 22, State Water Well Standards, the State OWTS Policy, California Plumbing Code.

### ***Effluent Limitations***

**Table 5-2** lists the effluent limitations contained in **Table 4** of the Order for different types of secondary and tertiary wastewater treatment systems. “Step 2” in the table addresses nitrogen effluent limitations which apply to wastewater systems with design flows greater than 20,000 gpd. The Order includes a process for assessing the level of nitrogen threat posed by the wastewater system based on the receiving environment and other factors in order to determine the appropriate effluent standard, which may be either (a) 50% removal or (b) a specific concentration limit that may be as low as 10 mg-N/L.

### ***Wastewater Pond Sizing***

Where ponds are used for winter storage of recycled water, the Order requires that wastewater pond sizing must be sufficient to: (1) accommodate the design wastewater flow plus precipitation based on water balance calculations incorporating 100-year frequency annual total precipitation value distributed monthly in accordance with average (mean) precipitation values; and (2) maintain two feet of freeboard.

## **Statewide General WDRs for Sanitary Sewers (SWRCB Order No. 2006-0003-DWQ)**

This is a general permit pertaining to the management of sanitary sewer systems of more than one mile in length that are owned or operated by a municipality, sanitary district or other public authority. This would apply to any of the community wastewater **Alternatives (3 through 5)** under consideration for the Woodacre-San Geronimo study area. For new facilities, enrollment under the General Permit must occur at least three months prior to start of operations. The Order requires the public authority to develop and implement a written Sewer System Management Plan (SSMP), including provisions to provide proper and efficient management, operation, and maintenance of sanitary sewer systems, while taking into consideration risk management, costs and benefits. Additionally, an SSMP must contain a spill response plan that establishes standard procedures for immediate response to a sanitary sewer overflow in a manner designed to minimize water quality impacts and potential nuisance conditions. The Order also contains spill notification, monitoring and reporting requirements.



## SECTION 6: PROJECT ALTERNATIVES

### INTRODUCTION

This section presents an analysis of each of the identified alternatives for the Woodacre – San Geronimo Study Area. To provide continuity and a frame of reference, the current study includes Non-Water Recycling project **Alternatives (1, 2 and 3)**, which are updated from the 2011 Woodacre Flats study along with several Water Recycling **Alternatives (4 and 5)** consistent with the project objectives. The analysis incorporates the results of field investigations and engineering studies from the 2011 study, along with additional data and analysis for the expanded project scope and service area. An overview of the project alternatives is provided in **Figure 6-1** on an annotated map of the study area.

Maps and other reference materials are provided for each alternative, along with a description of key facilities, engineering feasibility, estimation of construction costs and a discussion of on-going operation and maintenance requirements and costs. Supporting technical information is provided in the appendices. **Section 7** presents a comparative review of the various treatment and disposal alternatives and identifies the “apparent best alternative”.

### ALTERNATIVE 1 – NO PROJECT

#### Description

The No Project alternative, or status quo, is presented as a base case condition against which to judge other alternatives; however, no specific engineering evaluation has been made of this alternative. This alternative would provide for the continued use of onsite septic systems, with individual property owners responsible for maintenance and repair of their own systems. Permitting and regulatory responsibility would remain with the Marin County EHS and include oversight from the Regional Water Board. Correction of failing septic systems would normally be expected to occur under the following circumstances:

- As a direct result of abatement action taken by EHS for individual properties, in response to complaints;
- As a condition of sale at the time of property transfers;
- In connection with permits for building modifications; or
- By individual property owners on their own initiative.

Septic system repair work expected under this alternative might include, for example, replacement of existing substandard or failing septic systems with a new septic tank and disposal system. In most cases, an alternative system, such as a mound or advanced (“supplemental”) treatment unit with drip dispersal or pressure distribution leachfield, would likely be required because of particularly poor site conditions for standard septic tank/leachfield systems. These conditions include the shallow soil depths, seasonal high groundwater, setback constraints, and limited available land area on mostly small parcels. Retrofitting houses with ultra-low flush toilets and other water conserving plumbing devices would also be a necessity for many houses to reduce the volume of wastewater to be disposed. New residential construction,

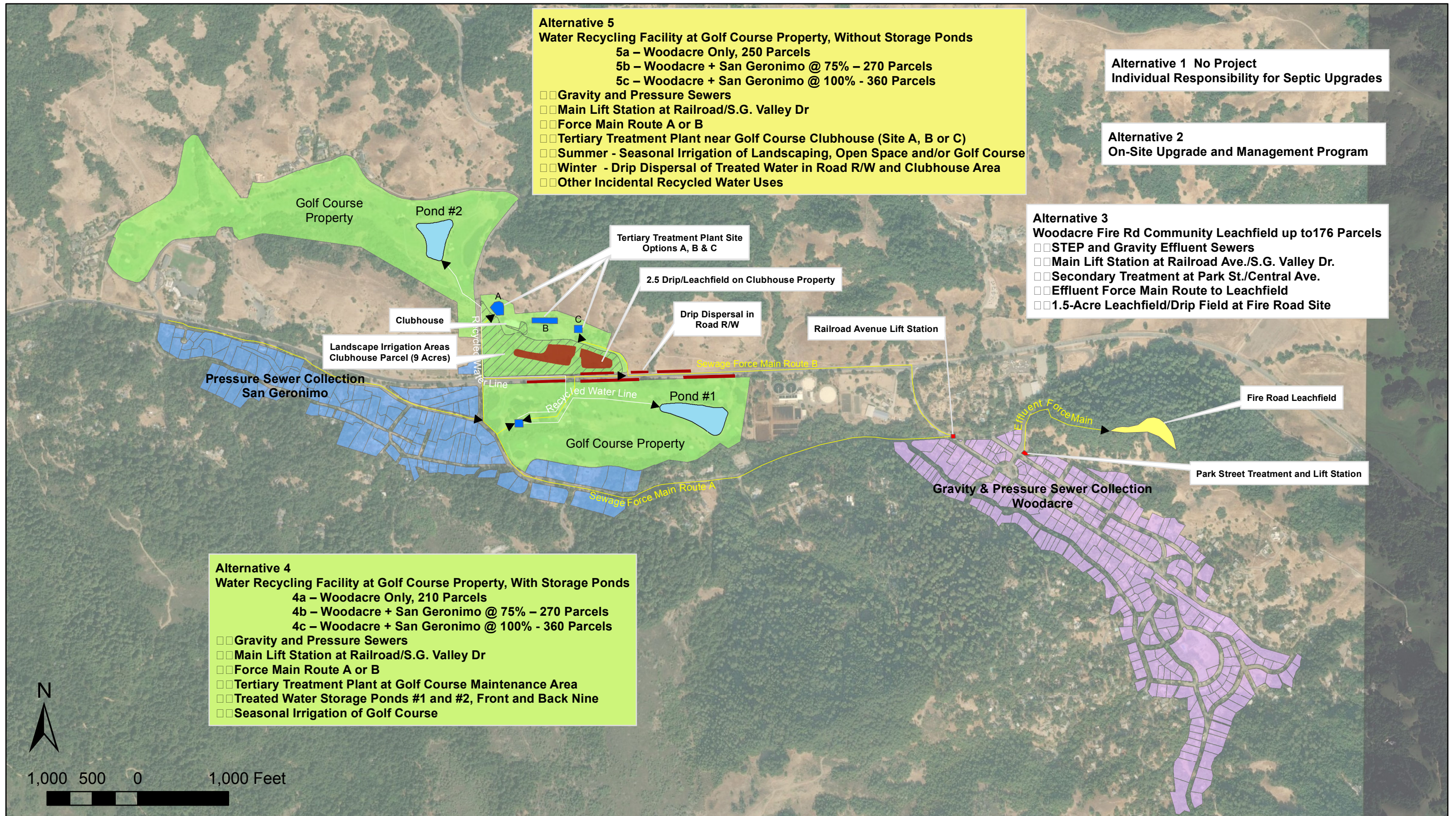

DATE:	2/7/2019
PROJECT:	WOODACRE WW
PROJECT NO:	1600073
DRAWN:	MF
APPROVED:	NH



**PROJECT ALTERNATIVES**

**FIGURE 6-1**

building additions and second units would not be permissible except where site conditions can support the installation of an onsite system that conforms to current code requirements and/or the County's Remodel & Additions Policy.

## **Discussion**

Over some period of time, the above-described efforts may lead to improved water quality and public health conditions in the community. But it is unreasonable to expect that the existing threat of water quality impact to Woodacre Creek, San Geronimo Creek and downstream receiving waters would be satisfactorily corrected. Under the No Project alternative, the possibility exists that Marin County EHS and/or the Regional Water Board would find it necessary at some point to undertake a systematic lot-by-lot inspection and abatement effort to mandate an upgrading of all septic systems to acceptable, modern standards. This could occur as a result of the implementation of the Tomales Bay Pathogens TMDL.

The TMDL requires that there be no discharge of human pathogens to Tomales Bay or its tributaries from septic systems. The TMDL further specifies that compliance with this requirement can be achieved by either: (a) documenting or bringing the septic system into conformance with Regional Water Board and County regulations for new construction; or (b) monitoring the septic system to verify compliance with the above "no pathogen discharge" performance standard. For existing septic systems in the watershed area found (or suspected) to be failing, the TMDL would require substantial upgrading (per Marin County Class 2 Repair Criteria), and ongoing monitoring of the new/replacement system under a County operating permit. However, the timing for implementing such corrective action is presently not specified.

As with other alternatives retaining onsite treatment with on-lot upgrades, there may be substantial yard disturbance and probable conflicts with existing or potential uses of the limited yard areas. In some cases, septic system upgrades may interfere with parking and require changes to landscaping.

## **Costs**

Costs for the No Project alternative are best estimated from the existing expenses incurred by individual property owners in connection with upgrades or repair of their onsite wastewater systems associated with building remodel projects, property transfers or repairs. Typical costs range from about \$35,000 on the low end up to as much as \$70,000, including soils testing, surveys, design, permitting and construction. Assuming most all systems require some alternative treatment components, the ongoing operation and maintenance requirements include service inspections, monitoring and reporting under the conditions of a County-issued Operating Permit, plus electrical usage, routine septic tank pump-outs, and replacement of parts and system components over the life of the system. Average annual operating maintenance costs typically range from about \$500 to \$1,500 for alternative onsite wastewater treatment systems, which includes the above items and annual County permit fees.

## ALTERNATIVE 2 - ONSITE SYSTEM UPGRADE AND MANAGEMENT PROGRAM

### Description

This alternative would provide for inspection and as-needed upgrading of existing septic systems in some portions or all of the study area, and formation of a septic system management authority to perform ongoing inspection, monitoring, and maintenance of these systems. Septic systems would need to be upgraded to a minimum set of standards, or determined to be in compliance with a minimum performance standard that would assure proper functioning and elimination of public health and water quality problems. The current standards of the Marin County EHS and the Regional Water Board would apply, with the possibility of adopting certain local modifications with concurrence by both of these agencies. In general, all applicable siting criteria (i.e., soil depth, percolation, groundwater, slope requirements, etc.) would be considered to the greatest extent possible in evaluating and designing septic system upgrades.

On-lot septic system improvements under this alternative would be similar to those for the No Project alternative; i.e., it would include replacement of substandard systems with new septic tanks, supplemental treatment units (e.g., sand filter or other supplemental treatment unit) and new disposal fields, most likely using pressure distribution or drip dispersal. Other alternative technologies might also be considered on a case-by-case basis, typically requiring demonstration to EHS of successful operation in other similar circumstances. Retrofitting houses with ultra-low flush toilets and other water conserving plumbing devices would also be a necessity for many houses to reduce the volume of wastewater to be disposed. The specific siting and design criteria for each alternative technology would have to be in accordance with currently adopted standards of the County and Regional Water Board, or based on criteria developed and agreed upon by both agencies specifically for this Project. In the course of developing this alternative during the 2011 Woodacre Flats study, appropriate criteria were determined in consultation with these agencies. The same criteria remain valid for the expanded Woodacre-San Geronimo study area, and are presented and used in the evaluation that follows.

Following septic system upgrading, a continued inspection and monitoring program would be carried out by a public management authority. This would entail regular inspection of each septic system, water quality sampling of treatment systems as well as Woodacre Creek and San Geronimo Creek, possibly other local drainages, and groundwater monitoring wells, with periodic reporting to the County and Regional Water Board on the inspection results and overall compliance with system performance, water quality and public health standards.

### Design Requirements

Criteria governing the siting and design of onsite sewage disposal facilities in the project area are described in **Section 5** of this report and cover such items as minimum soil depth, percolation rates, separation to groundwater, system design and sizing, and operation and maintenance. The standards are established to guide the installation of new systems. As previously noted for repair of existing septic systems, Marin County EHS attempts to achieve compliance with current regulations to the maximum extent practicable. However, full compliance with all code requirements is generally not possible. Heavy emphasis is given to case-by-case evaluation to achieve the best repair possible, considering the site limitations and environmental resources and public health issues at risk. **Table 6-1** lists the repair criteria and design assumptions that were developed during the 2011 wastewater study for application in an

onsite wastewater management program, at that time considering only the Woodacre Flats area. These were developed in consultation with EHS staff and the Regional Water Board staff in 2010. They have been reviewed and found still valid and equally applicable to the expanded service in the current study covering additional properties in Woodacre and San Geronimo.

**Table 6-1. Repair Criteria - Onsite Wastewater Management Program**

ITEM	CRITERIA / DESIGN ASSUMPTION
<b>Wastewater Design Flow</b>	<ul style="list-style-type: none"> <li>▪ Property owners responsible for installing ultra-low flush toilets and low flow fixtures;</li> <li>▪ Assume design flow of 105 gpd/bedroom;</li> <li>▪ Design flow of &lt;105 gpd/bedroom if necessary due to dispersal area limitations and with additional monitoring requirements (per below).</li> </ul>
<b>Septic Tanks</b>	<ul style="list-style-type: none"> <li>▪ Existing concrete/fiberglass tanks of 1,200 gal or greater may be retained if found to be structurally sound, watertight and are upgraded with code compliant access risers.</li> <li>▪ Effluent filters required for all new and upgraded tanks</li> <li>▪ Setbacks to water and landscape features to be maintained as close as possible to code requirements;</li> <li>▪ Setbacks to wells and springs - 50-ft minimum with variance from code.</li> </ul>
<b>Supplemental Treatment Units</b>	<ul style="list-style-type: none"> <li>▪ NSF Certification or equivalent technology verification required.</li> <li>▪ Performance standard: Per standard EHS protocol*; for special/extreme creek encroachment situations, TMDL receiving water standard for fecal coliform at end of supplemental treatment process (i.e., dosing tank) or at groundwater monitoring wells adjacent to disposal field. 50% nitrogen removal may be required per future Tomales Bay or Lagunitas Creek TMDLs.</li> </ul>
<b>Dispersal System</b>	<ul style="list-style-type: none"> <li>▪ All reasonable dispersal technologies may be considered, including trenches, beds, mounds, drip dispersal;</li> <li>▪ Design capacity – 100% of daily sewage flow; provide reserve area as feasible;</li> <li>▪ Design loading rate: per soil characteristics and percolation rate; treatment credit for supplemental treatment OK per established sand filter design criteria;</li> <li>▪ Setbacks to water and landscape features to be maintained as close as possible to code requirements;</li> <li>▪ Setbacks to wells and springs - 100-ft minimum</li> </ul>
<b>Site Modifications</b>	<ul style="list-style-type: none"> <li>▪ Utilize curtain drains and surface drainage alteration wherever needed and feasible without impacts to/from other onsite systems or to surface waters;</li> <li>▪ Soil excavation and replacement with sand fill – not normally allowed but may be considered case-by-case, e.g., for removal/improvement of compacted fill area.</li> </ul>
<b>Performance Monitoring</b>	<ul style="list-style-type: none"> <li>▪ Wastewater flow: Monitor from pump operations and/or water meter; require flow meter (or comparable device) and data logging for systems without 100% disposal capacity;</li> <li>▪ Monitoring: water quality sampling required for coliform for special case systems at pump basin (following supplemental treatment), once/year;</li> <li>▪ Visual inspection and maintenance once per year minimum;</li> <li>▪ Remote alarm monitoring for identified high risk systems, e.g., creek encroachment with less than 100% disposal capacity.</li> </ul>
<b>Other Alternatives</b>	<ul style="list-style-type: none"> <li>▪ Holding tanks: May be required case-by-case to overcome extreme site limitations, such as soil/groundwater/drainage conditions or watercourse setbacks;</li> <li>▪ Composting toilets: Not anticipated to be feasible or acceptable in high density residential areas such as Woodacre and San Geronimo.</li> <li>▪ Graywater Systems: Case-by-case evaluation based on State and County Graywater Standards</li> </ul>

*\*Includes operating permit with standard and site-specific inspection, testing, and reporting requirements*

## Discussion

An assessment of onsite wastewater disposal feasibility for lots within the Woodacre and San Geronimo Study Area was completed utilizing the repair criteria listed in **Table 6-1**. Background file information, to the extent available, was utilized and combined with a field reconnaissance review of a representative cross-section of properties conducted during the 2011 Woodacre Flats study for this assessment. **Section 3** provides a description and summary of findings of the permit records and field reviews; additional details are provided in the 2011 Woodacre Flats project report.

Briefly, the objective of the permit records and onsite field reviews was to: (a) assess the apparent available area for onsite septic system upgrade; (b) identify and evaluate some of the main construction issues and constraints that would be involved with the implementation of onsite system upgrades; and (c) assess and categorize the properties according to potential options for implementing an onsite system upgrade in accordance the basic repair criteria outlined in **Table 6-1**. This resulted in establishment of three upgrade/repair categories based on the level of difficulty and associated work required, as described previously in **Section 3** under Onsite Field Reviews and briefly as follows:

- **Low Level** – This was assigned to properties having an existing Class 1 or Class 2 code system, where little or no repair or upgrade work would be anticipated.
- **Moderate Level** – This was assigned to properties having sufficient area and reasonably good soil and groundwater conditions that could accommodate relatively straight forward upgrades to either the treatment or disposal system.
- **High Level** - This was assigned to properties having severe space limitations along with shallow soil/high groundwater conditions and/or drainage setback constraints requiring considerable work to implement a satisfactory onsite upgrade/repair.

Literature on some of the onsite wastewater treatment technologies commonly used for system upgrades in areas with difficult siting constraints is provided in **Appendix A**. Generic examples of typical repair and upgrade options representative of Moderate and High Level categories are illustrated in **Appendix B**.

The 2011 Woodacre Flats study estimated the percentage of properties in each septic system upgrade level to be as follows:

- Low Level: 15%
- Moderate Level: 12%
- High Level: 73%

For the current study, the same percentages were used to estimate the probable septic system upgrade requirements for the total expanded number of properties in Woodacre and San Geronimo communities, which are presented in **Table 6-2**.

**Table 6-2. Onsite System Upgrade Assessment Needs Summary**

Area	Total Properties	Estimated Level of Upgrade (# of properties)		
		Low	Moderate	High
Woodacre Subarea	250	38	30	182
San Geronimo Subarea	110	16	13	81
Total	360	54	43	263
Percent of Total	100%	15%	12%	73%

## Operation and Maintenance Needs

Following septic system upgrading, a continuing inspection and monitoring program would be carried out by a public maintenance authority; this is assumed to be a requirement of both the County and the Regional Water Board for implementation of the Tomales Bay Pathogens TMDL. This would be expected to entail the following routine items:

- Inspection of each system, normally once per year;
- Water quality sampling of the effluent from a representative number of treatment units; assume 20 percent of systems sampled each year and all systems sampled at least once every five years;
- Groundwater and surface water quality monitoring;
- Reporting water quality failures or malfunction of systems;
- Annual reporting to the County and Regional Water Board on the inspection results and overall compliance with water quality and system performance standards; and
- Periodic cleaning and pumping of septic tanks/treatment units, usually every 3 to 5 years.

There would be electrical costs associated with the operation of the advanced treatment systems, any UV disinfection units, and the pump systems used for dosing the pressure distribution and drip dispersal fields. Each property owner would be responsible for providing and maintaining electrical service. From time-to-time, various system components (such as valves, UV light bulbs, pumps and float controls) would require repair or replacement. The need for this work would be determined by the maintenance authority; depending upon the complexity, the actual repair/replacement work could be done by the maintenance authority, a contractor or, possibly, the property owner.

To facilitate system maintenance and oversight, it is assumed that a telemetry control system would be included in the system design, so that alarm conditions at individual systems can be relayed and monitored at a remote location by the responsible maintenance authority or contractor.

## Estimated Costs

### *Capital Costs*

**Table 6-3** summarizes the estimated range in cost that would be anticipated for an individual system upgrade within Low, Moderate and High Level upgrade categories, as discussed above. Supporting cost estimation details and assumptions are provided in **Appendix B**. The costs were developed based on Questa's experience with these types of onsite system projects in

Marin County, and included consultation with local contractors, manufacturers, and equipment suppliers. In addition to new construction items, the upgrade costs also include allowance for abandonment of the existing system (as required), electrical work, site restoration, permitting, and testing. The costs do not include an allowance for retrofitting of buildings with low-flow plumbing fixtures or appliances, which would be a homeowner responsibility and likely has already been done in many instances. Cost allowances for contingencies, engineering, environmental, and related project implementation activities are accounted for as lump sum items for this project alternative as a whole, rather than for individual systems (see below).

**Table 6-3. Estimated Individual Onsite System Upgrade Costs**

Item	Low Estimate (\$)	High Estimate (\$)	Average (\$)
Low Level Upgrade	1,500	4,500	3,000
Moderate Level Upgrade	27,500	30,000	28,750
High Level Upgrade	36,000	51,000	43,500

Using the estimated number of upgrades by level of work provided in **Table 6-2** and the estimated average per system upgrade costs in **Table 6-3**, overall cost estimates for this alternative were developed. The overall project costs are summarized in **Table 6-4**. As indicated, in addition to individual system construction, the total project cost estimate includes other allowances as follows: (a) 15% contingency; (b) 15% for engineering and environmental studies; (c) 10% for construction management; and (d) 5% for project administration, district formation and financing. As indicated, the total estimated capital costs for **Alternative 2** would be on the order of about \$19.2 million for 360 developed properties in the combined Woodacre and San Geronimo service areas. The corresponding average cost per parcel is estimated to be approximately \$53,300.

### **Operation and Maintenance Costs**

Annual operation and maintenance costs for the onsite management alternative are summarized in **Table 6-5**. The estimates are based on best professional judgment and experience with onsite system monitoring activities in Marin County and with other onsite wastewater management programs. As indicated, O&M costs for this alternative include district and program administration costs, labor and expenses to perform the necessary system inspections and reporting, an allowance for equipment and material costs associated with system maintenance and replacement, laboratory costs for water quality sampling and analysis, electrical costs for individual treatment/disposal system equipment (directly absorbed by property owners), and routine septic tank pump-outs. An allowance of 10% is included as a contingency. As indicated, the total annual O&M cost for **Alternative 2** is estimated to be approximately \$348,500 for the full Woodacre-San Geronimo service area. The corresponding annual cost per parcel would be approximately \$968.



**Table 6-4. Estimated Capital Costs for Onsite Upgrade and Management Program**

Upgrade Work Category	Number of Systems	Average Cost per System	Total Cost (\$)
Low Level	54	3,000	\$162,000
Moderate Level	43	28,750	\$1,236,250
High Level	263	43,500	\$ 11,440,500
<b>Subtotal</b>			<b>\$ 12,838,750</b>
<b>Contingency @ 15%</b>			<b>\$ 1,925,800</b>
<b>Subtotal</b>			<b>\$ 14,764,550</b>
<b>Engineering and Environmental Studies @ 15%</b>			<b>\$2,214,680</b>
<b>Construction Management @ 10%</b>			<b>\$ 1,476,455</b>
<b>Project Administration, District Formation and Financing @ 5%</b>			<b>\$ 738,230</b>
<b>TOTAL</b>			<b>\$ 19,193,915</b>
<b>Average Cost Per Connection (360 parcels)</b>			<b>\$ 53,316</b>

**Table 6-5. Estimated Annual O&M Costs, Onsite Management Program**

Items	Assumptions	Estimated Annual Cost (\$)
District/Program Administration	Insurance, legal, financial, permits @ \$150/parcel	\$ 54,000
On-lot System Inspection, Monitoring & Reporting	Annual inspection of all systems, remote monitoring, data compilation, annual reporting, as-needed engineering consultation @ \$300 ea	\$108,000
Maintenance	Equipment, materials, maintenance & replacement @ \$200/yr each	\$72,000
Laboratory & Expenses	Sampling 20% of individual treatment systems annually, surface and groundwater sampling, travel expenses and supplies	\$36,000
Electrical*	Property owner expense for treatment & dispersal pumps and other electro-mechanical items @ \$30/yr	\$10,800
Septic Tank Pumping*	25% of tanks pumped annually @ \$400 each	\$36,000
<b>Subtotal</b>		<b>\$ 316,800</b>
<b>Contingencies (@ 10%)</b>		<b>\$ 31,680</b>
<b>TOTAL</b>		<b>\$ 348,480</b>
<b>ANNUAL COST PER PARCEL</b>		<b>\$ 968</b>

\*Individual property owner cost varies according to system type, occupancy and use.

## Summary

The onsite upgrade and management alternative would substantially reduce present water quality and public health problems, bring more (as opposed to the No Project option) of the existing onsite systems into conformance with accepted practices, and would do so in a timely manner. The primary shortcoming of this alternative is the heavy reliance on advanced treatment systems and the substantial variances to normal siting and design standards – especially in regard to soil conditions and setbacks from watercourses. This alternative will require on-going care, maintenance, and monitoring of each onsite wastewater system.

The septic system upgrade efforts, along with establishment of an onsite management program, would largely eliminate the public health hazards and water quality threat from septic systems in the local community, and contribute to improved conditions in downstream receiving waters. Existing seepage pits and other disposal systems that drain directly into groundwater or periodically experience surface failures would be eliminated in favor of advanced treatment units, disinfection in some cases, and upgraded dispersal systems, including raised drip disposal beds and other similar alternative technologies. The institution of an onsite wastewater management program would provide the means for monitoring the performance of all upgraded systems, as well as the local environment, for possible wastewater impacts. Potential negative aspects of this plan would be the land disturbance required on individual properties to upgrade on-lot disposal systems, and probable conflicts with other existing or potential uses of the limited yard areas. The septic system upgrades may interfere with parking in some cases and require changes to landscaping.

This alternative represents a substantial improvement in reliability over existing conditions, through the proposed implementation of an onsite inspection and maintenance program. **Alternative 2** would also introduce some additional flexibility for septic system management, by providing for the use of holding tanks (if needed in special cases), and perhaps other design alternatives that would not be approved for operation by individuals outside of a septic system management program, e.g., under the No Project alternative.

**Alternative 2** would not bring about any significant land use/development changes in the study area; however, an onsite wastewater management program could make it possible for house remodeling and some amount of additions to existing structures. There would be no assurance that undeveloped properties could be developed, or that house additions/remodeling could be undertaken without restrictions and conformance with Marin County EHS Remodel Policy.

## **ALTERNATIVE 3 – FIRE ROAD COMMUNITY LEACHFIELD (WOODACRE ONLY)**

### **Description**

This alternative provides a potential community wastewater solution to serve a portion (roughly 70%) of the properties in the Woodacre service area. It does not offer capacity to serve properties in San Geronimo or identify an alternate similar community leachfield-type facility that could potentially serve San Geronimo.

This alternative was developed in the 2011 Woodacre Flats study and provides for the construction of a central wastewater collection system in the Flats area, leading to a community leachfield system located on nearby forested lands (**Figure 6-2**). The area identified as a potential community leachfield site is a wooded knoll along the Fire Road ridgeline northeast of Woodacre on property owned by Dickson Ranch. During the 2011 study, the property owners granted access to Questa Engineering staff for field studies to evaluate various locations on the Dickson Ranch for potential use as a community wastewater treatment and disposal site for Woodacre Flats. Three different community leachfield options were formulated and evaluated, with the preferred option consisting of a secondary treatment system (AdvanTex textile filter) with a shallow pressure distribution leachfield, which is presented here as **Alternative 3** for the current study.

The main differences in **Alternative 3** as compared with the information presented in the 2011 study are: (a) revised capacity to serve 176 rather than 150 properties; (b) revisions to treatment system configuration to meet current manufacturer recommendations for nitrogen removal; and (c) installation of a dual (200%) capacity leachfield, rather than a 100% field with 100% designated reserve area. The treatment and disposal facilities would be designed for a daily wastewater flow of 26,400 gpd.

Details and supporting background information for **Alternative 3** are provided in **Appendix C** and in the 2011 Woodacre Flats project report. The 2011 study indicated an **Alternative 3B** as the preferred leachfield design option. The following discussion of key elements is based on this preferred the leachfield alternative, modified to provide 200% as noted above.

### **Collection System**

Sewage collection would be provided by a combination of septic tank effluent pump (STEP) and small diameter (4-inch) gravity effluent sewers. This includes the continued use of existing or upgraded on-lot septic tanks, cluster tanks for multiple properties in some cases, and a system of 2-inch to 4-inch diameter pressure piping to bring the septic tank effluent to a central treatment plant location at Park Street. About 50 parcels along Central Avenue would be able to drain by gravity to the Park Street treatment plant location. The majority of the parcels through the center of service area would connect to a gravity effluent main running down Railroad Avenue to an underground lift station at the intersection of Railroad and San Geronimo Valley Drive; from there the effluent would be pumped to the Park Street treatment plant site.

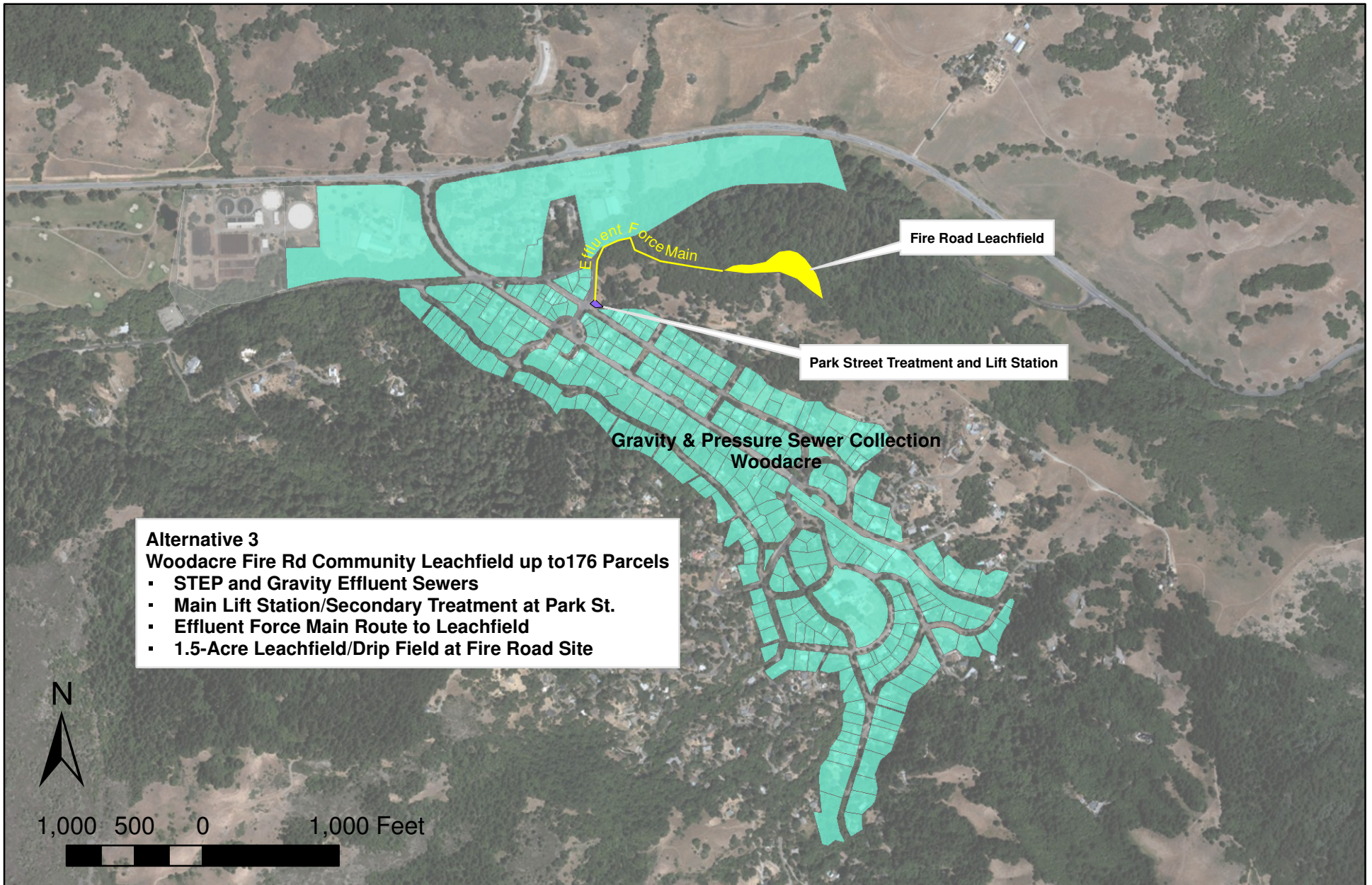

**Alternative 3**  
**Woodacre Fire Rd Community Leachfield up to 176 Parcels**

- STEP and Gravity Effluent Sewers
- Main Lift Station/Secondary Treatment at Park St.
- Effluent Force Main Route to Leachfield
- 1.5-Acre Leachfield/Drip Field at Fire Road Site

DATE:	2/9/2017
PROJECT:	WOODACRE WW
PROJECT NO:	1600073
DRAWN:	MF
APPROVED:	NH



**ALTERNATIVE 3**

**FIGURE  
6-2**

## **Wastewater Treatment**

Advanced secondary treatment, including nitrogen removal, would be provided for all effluent prior to dispersal to the community leachfield.

- **Primary Treatment.** Septic tanks at individual properties (possibly some cluster locations) would provide primary treatment. Some existing tanks may continue to be used, as is, and others would be upgraded or replaced with new water-tight tanks, typically 1,200-gallons capacity.
- **Secondary Treatment.** A secondary treatment system would be provided and is proposed to be located in County-owned right-of-way in at the intersection of Park Street and Central Avenue in Woodacre, occupying an area of approximately 10,000 ft<sup>2</sup>. Various treatment system types are available for this application. For feasibility analysis, the recommended system best meeting project requirements would be an AdvanTex recirculating textile filter, including provisions for enhanced nitrogen removal (>50% removal rate). This type of system is recognized in County Regulations and in use locally at Spirit Rock Center, the Marshall Community Wastewater System, and others places in the County. A schematic layout of the wastewater treatment facilities is provided in **Figure 6-3**. Key features of the facility are listed below. Except for the control shed, these units can be located underground:
  - Flow equalization tank – 10,000 gallons
  - Pre-anoxic tank – 30,000 gallons
  - AdvanTex recirculation-blend tank – 30,000 gallons
  - AdvanTex treatment “pods” – 11 units @ 2,500 gpd/each, total 27,500 gpd
  - Effluent Lift Station – 15,000 gallons
  - 250 ft<sup>2</sup> control building, telemetry system, emergency generator, fencing and landscaping

## **Wastewater Disposal**

Wastewater disposal would be provided by a dual (200% capacity) pressure distribution system located on an approximately 1.5-acre wooded knoll on Dickson Ranch property located along the Fire Road ridgeline. Description of soil investigations and findings are provided in **Appendix C** and in the 2011 Woodacre Flats project report. All test pits showed similar soil conditions, consisting of loam and sandy loam topsoils underlain by highly weathered sandstone to the depth explored. No groundwater or evidence of seasonal saturation was observed in any of the profiles.

Leachfield design parameters are as follows:

- Design flow: 26,400 gpd, dual alternating fields
- Pressure distribution leachfield, w/Infiltrator chambers
- Trench depth - 30 inches
- Trench width - 36 inches
- Effective infiltrative area – 5 ft<sup>2</sup> per linear feet (lf) of trench, bottom area + sidewall (note: this is based on Regional Water Board onsite system minimum guidelines; Marin County regulations for systems <10,000 gpd design flow specify sizing based on sidewall only)
- Wastewater application rate – 1.6 gpd/ft<sup>2</sup> (2 x standard septic tank effluent rate); 8 gpd/lf

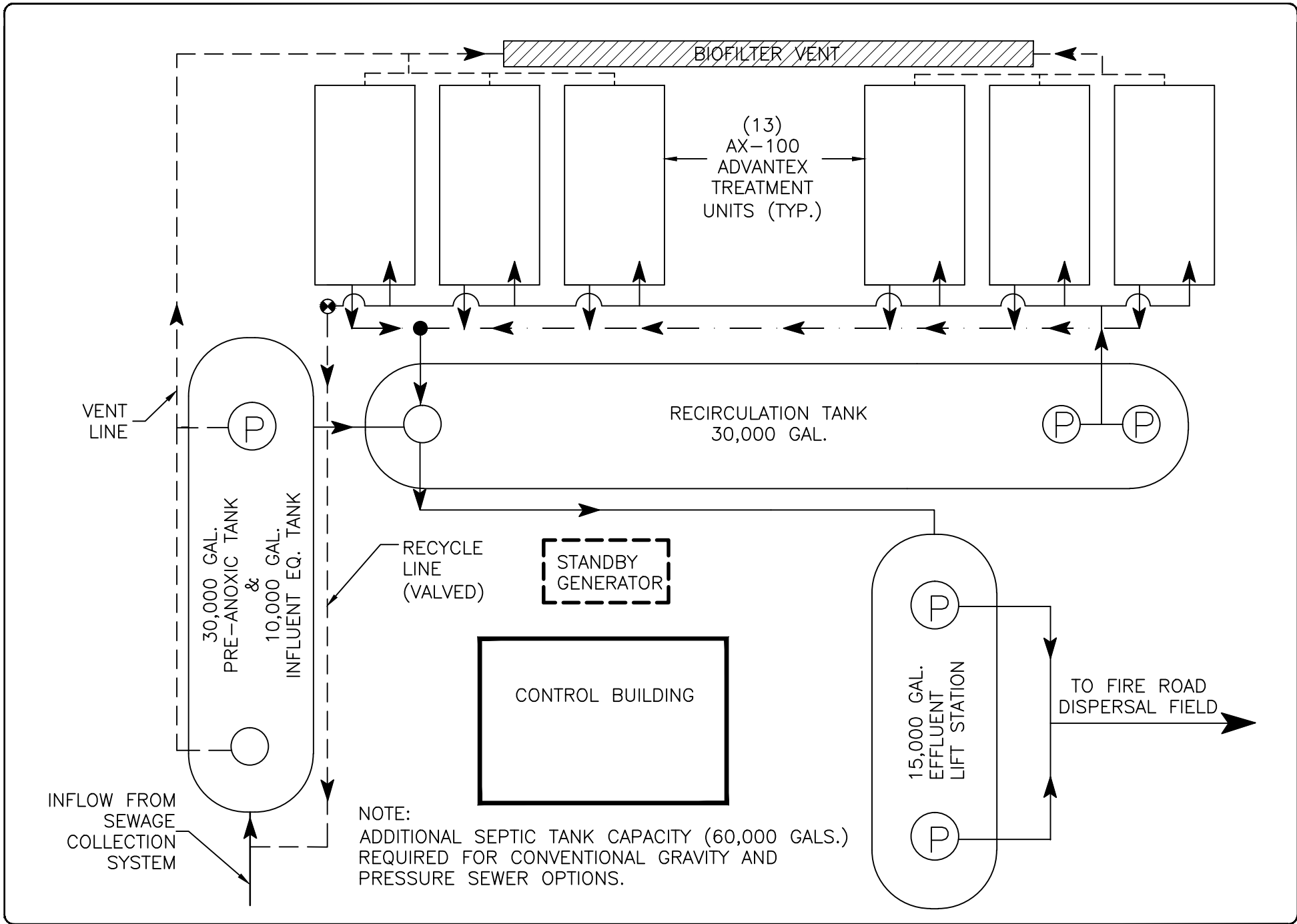

DATE PLOTTED: 2/12/2017 PAGE: 2 OF 2

Sheet	Rev.	Date	By	Description	App'd

Design:	NH/PP
Drawn:	ML
Checked:	PP
App'd:	NH

- Total trench length – 6,600 lf (3,300 lf primary, 3,300 lf secondary)
- Trench spacing - 10 feet, on-center
- Total leachfield area - 1.5 acres
- Setbacks – No streams within 200+ feet; no wells within 500 feet

Other components required for the community leachfield would include the following:

- **Effluent Force Main.** 4-inch diameter effluent force main, approximately 2,200 feet long, to convey treated wastewater from the Park Street treatment facility to the Fire Road site. The recommended route would be via Park Street, then San Geronimo Valley Drive, and then overland through Dickson Ranch property along the ridgeline to the Fire Road leachfield site.
- **Effluent Dosing Station.** An effluent dosing (pump) station would be installed near the southerly end of the Fire Road site (high point). It would consist of a large underground tank (e.g., 15,000 gallon fiberglass) and multiple pumps and control system. The control panel would be housed in a small building or enclosure (e.g., <100 ft<sup>2</sup>). For emergency purposes (power or pump outages), a gravity dosing tank to a series of overflow leachlines would be installed and the control system would be designed to be operated with a portable generator.
- **Electrical Power.** Electrical power from PG&E would be brought to the Fire Road site from the nearest location, estimated to be about 1,500 feet away on Fire Road; provisions for temporary operation of the dosing pumps with a portable generator will also be provided.
- **Fencing.** The 1.5-acre leachfield site, including the dosing station, would be fenced with typical farm fencing (barbed wire) to keep animals out of the site.
- **Fire Road Access Improvements.** Improvements (grading and gravel surface) would be made to Fire Road to provide all weather vehicle access to the leachfield site.
- **Land Acquisition.** The land for the leachfield and the effluent force main to the site would have to be purchased or an easement acquired from the Dickson Ranch. The property owners willingly granted access for the investigation of the Fire Road leachfield site as well as preliminary exploration of other areas of the Dickson Ranch. They indicated interest in cooperating with the community and also expressed interest in possibly being incorporated into the service area for a community wastewater system.

## Operation and Maintenance Requirements

The community collection, treatment and disposal facilities under **Alternative 3** would be owned and operated by the wastewater district formed as part of the project. The actual operations and maintenance work would be performed or overseen by a qualified wastewater treatment plant operator. Local maintenance contractors may be hired to perform routine inspection, maintenance, and monitoring activities. Operation and maintenance activities can be expected to include the following:

- **Facility Inspections, Maintenance and Operations.** This includes routine inspections and maintenance of the individual septic tanks and STEP units, collection system

pipelines and valves, lift stations, community treatment system, leachfield dosing pumps and pipelines, and leachfield piping, trenches and valves, and all electrical/mechanical control equipment. Other maintenance work includes the pump-out and hauling of sewage solids from septic tanks and other treatment units, general upkeep of the treatment plant grounds, and periodic servicing or replacement of equipment. The inspection, maintenance and operations of the facilities would be conducted on an as needed basis; it would be facilitated by remote telemetry equipment for notification of alarm conditions. Some level of onsite inspection and/or maintenance work is likely to occur on a weekly basis or a few times a week.

- **Performance Monitoring.** The waste discharge permit for the community wastewater facilities would require routine monitoring of the wastewater treatment and disposal facilities to verify compliance with performance standards and proper operation. A formal monitoring and reporting program would be established by the Regional Water Board as a permit condition. This is anticipated to include monitoring of wastewater flow (daily), influent and effluent quality, and disposal field conditions.
- **Receiving Water Quality Sampling.** There would likely be requirements for sampling and analysis of groundwater near and downgradient of the leachfield area. The expected parameters of interest would be nitrate and coliform bacteria and groundwater levels, typically on a monthly basis. There are no surface waters near the Fire Road leachfield site that would require monitoring.
- **Reporting.** The monitoring results would be summarized and submitted in monitoring reports (e.g., monthly or quarterly) to the Regional Water Board. An annual report would be prepared that presents the monitoring results, compares the results with the discharge requirements and performance objectives for the system, and discusses any problems, corrective actions, or other pertinent observations regarding operation of the system. It would also include results of an annual inspection of each individual septic tank and a log of tanks that required pumping.

## Estimated Costs

### *Capital Costs*

The estimated capital costs for **Alternative 3** are summarized in **Table 6-6** for assumed service for 176 properties in Woodacre. Itemized cost estimates including quantities and unit cost assumptions are provided in **Appendix C**. The cost assumptions were developed through discussions with manufacturers, equipment suppliers, and local contractors, and through review of recent contractor bids for similar work in Marin County, where applicable. The bottom line in the table converts the total project costs to average cost per connection, based on 176 connections.

### *Operation and Maintenance Costs*

The estimated annual operation and maintenance costs for **Alternative 3** are presented in **Table 6-7**. Supporting itemized calculations and assumptions are provided in **Appendix C**. The O&M costs were estimated based on labor, equipment, materials and other expenses required to perform the necessary inspections, water quality sampling, data analysis, report preparation, pump-outs, and routine maintenance and equipment replacement for the



community treatment and disposal facilities, as well as for the collection system and all individual STEP/STEG units served by the system. Also included are estimates of annual energy costs (electrical) for operation of the community treatment system and pumps. The electrical costs for individual STEP units at each property (estimated to be a few dollars per month) are not included. A 10% contingency allowance is also included. The cost estimates were developed based on the expected operation and monitoring needs defined above, and using data and experience from monitoring and maintenance of other similar systems in Marin County and other Northern California communities, including the Marshall Community Wastewater System. As indicated, the total annual O&M costs are estimated to be \$159,610, amounting to approximately \$900 per parcel.

**Table 6-6. Estimated Capital Cost - Fire Road Community Leachfield**

<b>Cost Item</b>	<b>Estimated Capital Costs (\$)</b>
Collection System (Effluent STEP/STEG)*	2,697,175
Treatment System	735,000
Disposal System	772,500
Land/Easement Costs	100,000
Mobilization/Demobilization	100,000
Permit Fees & Encroachment Fees	30,000
Subtotal	<b>4,434,675</b>
Contingency @ 15%	665,201
Subtotal	<b>5,099,876</b>
Engineering & Environmental Studies @ 15%	764,981
Construction Management @ 10%	509,988
Admin, District Formation, Financing @ 5%	254,994
<b>Total Estimated Cost</b>	<b>6,629,839</b>
<b>Estimated Cost Per Connection</b>	<b>37,670</b>

\*Note: The costs for replacement tanks and upgrading of existing tanks are included in the cost estimates. However, it does not include cost for abandonment of septic tank (where required) and any work to connect house plumbing to new facilities, which is responsibility of property owner: this typically ranges from \$1,500 to \$3,000, depending on access and property conditions

**Table 6-7. Estimated Annual O&M Costs – Fire Road Community Leachfield**

<b>Items</b>	<b>Assumptions</b>	<b>Estimated Annual O&amp;M Cost (\$)</b>
<b>District/Program Admin.</b>	Insurance, legal, financial, permits	28,000
<b>Inspection, Monitoring &amp; Reporting</b>	On-lot STEP/STEG systems, lift stations, treatment/disposal system; remote telemetry; monthly/annual reports; as-needed engineering	63,600
<b>Maintenance</b>	Equipment, materials, maintenance & replacement; site maintenance; sewer cleaning	27,200
<b>Laboratory &amp; Expenses</b>	Monthly treatment system and monitoring well sampling and analysis, travel expenses & supplies	11,400
<b>Electrical</b>	Treatment plant, lift stations & leachfield dosing	14,900
<b>Septic Tank Pumping</b>	Individual owner responsibility	•
	Subtotal	\$145,100
	Contingencies (@ 10%)	\$14,510
	<b>TOTAL</b>	<b>\$159,610</b>
	<b>ANNUAL COST PER PARCEL</b>	<b>\$907</b>

## **Alternative 4 – Water Recycling System With Storage Ponds**

**Alternative 4**, with three variations (**a**, **b** and **c**), is oriented specifically toward utilizing recycled water for golf course irrigation. While continued use of the golf course is uncertain, this alternative remains for planning purposes for future golf course consideration. This alternative is designed to maximize the amount of water available for golf course use by construction and use of holding ponds to store treated water during the wet season, along with incident rainfall collected in the ponds. This alternative, on average, would provide from 18% to 33% of the historical golf course irrigation water demand. **Alternative 5** would also produce recycled water for irrigation use; however, it would not include holding ponds and would be able to supply about 12% to 17% of the golf course demand.

### **Alternative 4a – Woodacre Only, 210 Parcels**

#### **Description**

This alternative corresponds with **Alternative 4** from the 2011 Woodacre Flats study. It includes collection, treatment, and recycling of wastewater for turf irrigation at the San Geronimo Golf Course, with service limited to Woodacre only. It would have capacity for approximately 210 parcels, roughly 85% of the 250 total parcels in the Woodacre portion of the study area. It would not provide capacity to serve any properties in San Geronimo. The system would have a capacity to accommodate an estimated average daily flow of approximately 26,000 gpd and peak flow of 35,000 gpd. Under average year rainfall conditions, the project

would produce approximately 28.3 acre-feet (9.2 million gallons) of recycled water for golf course irrigation, allowing about an approximate 18% reduction in raw water obtained from MMWD.

The main elements of this alternative include: (a) central wastewater collection system extending throughout the Woodacre service area (gravity and pressure sewers); (b) main lift station located near the intersection of Railroad Avenue and San Geronimo Valley Drive; (c) wastewater transmission line (force main) to the San Geronimo Golf Course (preferred route via Sir Francis Drake Boulevard); (d) tertiary recycled water treatment plant located in the golf course maintenance area; (e) an approximately 2-acre holding pond on the front nine of the golf course (near green #2) for winter storage of recycled water; and (f) seasonal reuse of the recycled water for spray irrigation of the golf course, integrated into the existing irrigation system. **Figure 6-4** is a map showing the location of key features of this alternative. **Figure 6-5** provides an overall schematic of the wastewater treatment and recycling system.

The main differences in **Alternative 4** as compared with the water recycling alternative presented in the 2011 Woodacre Flats study are:

- 1) Overall depth and storage capacity of the recycled water holding pond has been increased to the maximum extent practicable within the available area near green #2;
- 2) Capacity of the pond has been re-calculated based on provision for storage of 100-yr seasonal rainfall, per changes in State requirements adopted in 2014 (previously 10-yr rainfall capacity was required);
- 3) Pond storage capacity and recycled water production has been re-calculated based on updated/revised estimates for average unit wastewater flows during wet season and dry season (per discussion in Section 4); and
- 4) Overall capacity has been increased by about 40%, from 150 up to 210 parcels. The proposed facilities would also include capacity for treatment and recycling of wastewater flows from the golf course clubhouse and maintenance area.

The wastewater would be treated to meet California Title 22 requirements for disinfected tertiary recycled water, and would be incorporated into the existing golf course irrigation system, reducing the amount of raw water supplied to the golf course from MMWD. The overall concept and main elements of this alternative have been developed in consultation with the previous golf course owners and maintenance personnel.

Key elements of this alternative are summarized below.

### ***Collection System***

The recommended sewage collection method for this alternative is a conventional gravity system, with a main lift station located at the northeast corner of Railroad Avenue and San Geronimo Valley Drive. Because of the undulating terrain, a pressure sewer would be used for properties along Redwood Drive, tying in at the main lift station. From the lift station, the sewage would be conveyed to the treatment plant location at the golf course maintenance area in a 4-inch diameter force main. There are two possible routes for the force main, as follows:

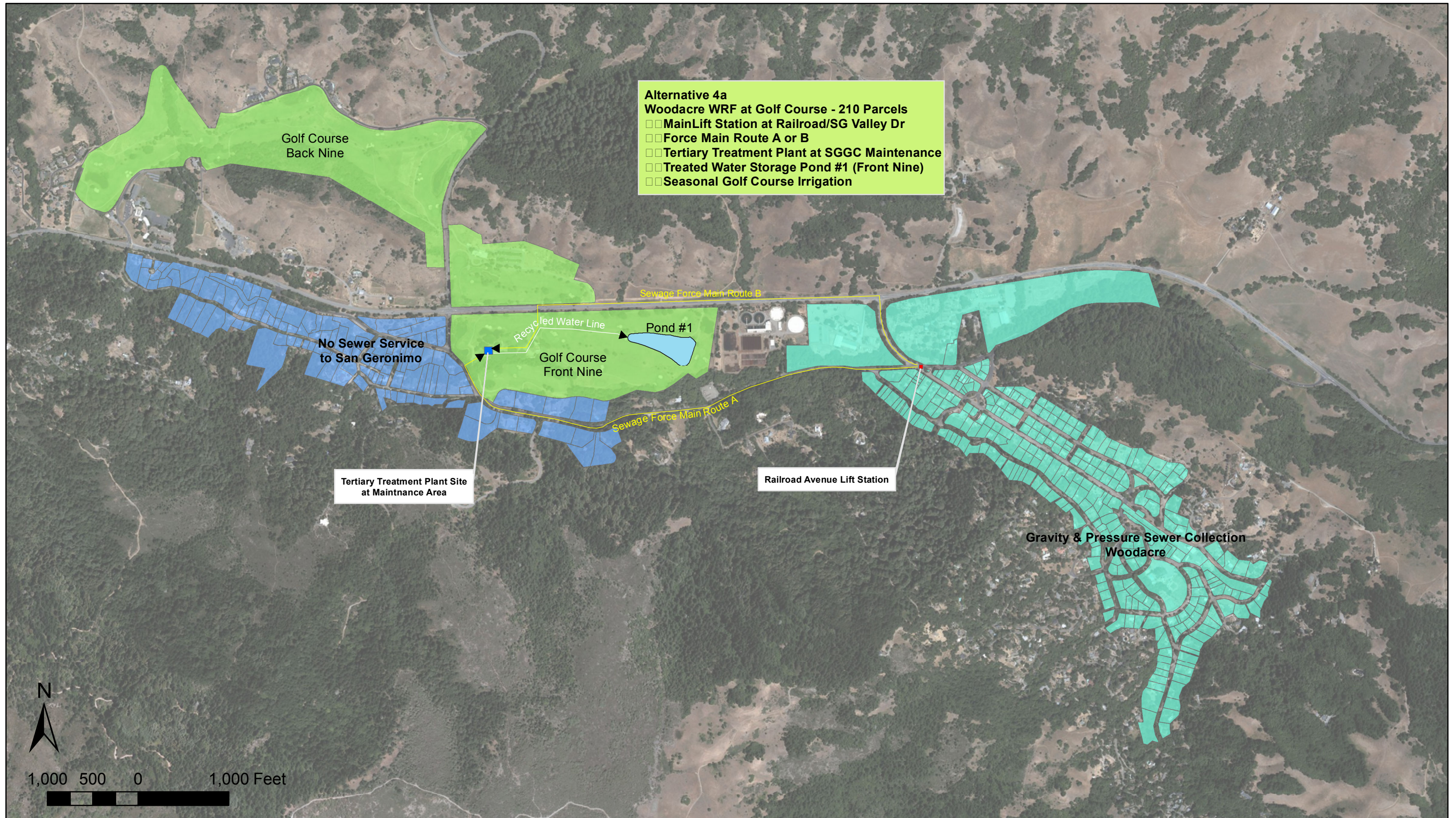

DATE:	2/7/2019
PROJECT:	WOODACRE WW
PROJECT NO:	1600073
DRAWN:	MF
APPROVED:	NH



**ALTERNATIVE 4a**

**FIGURE 6-4**

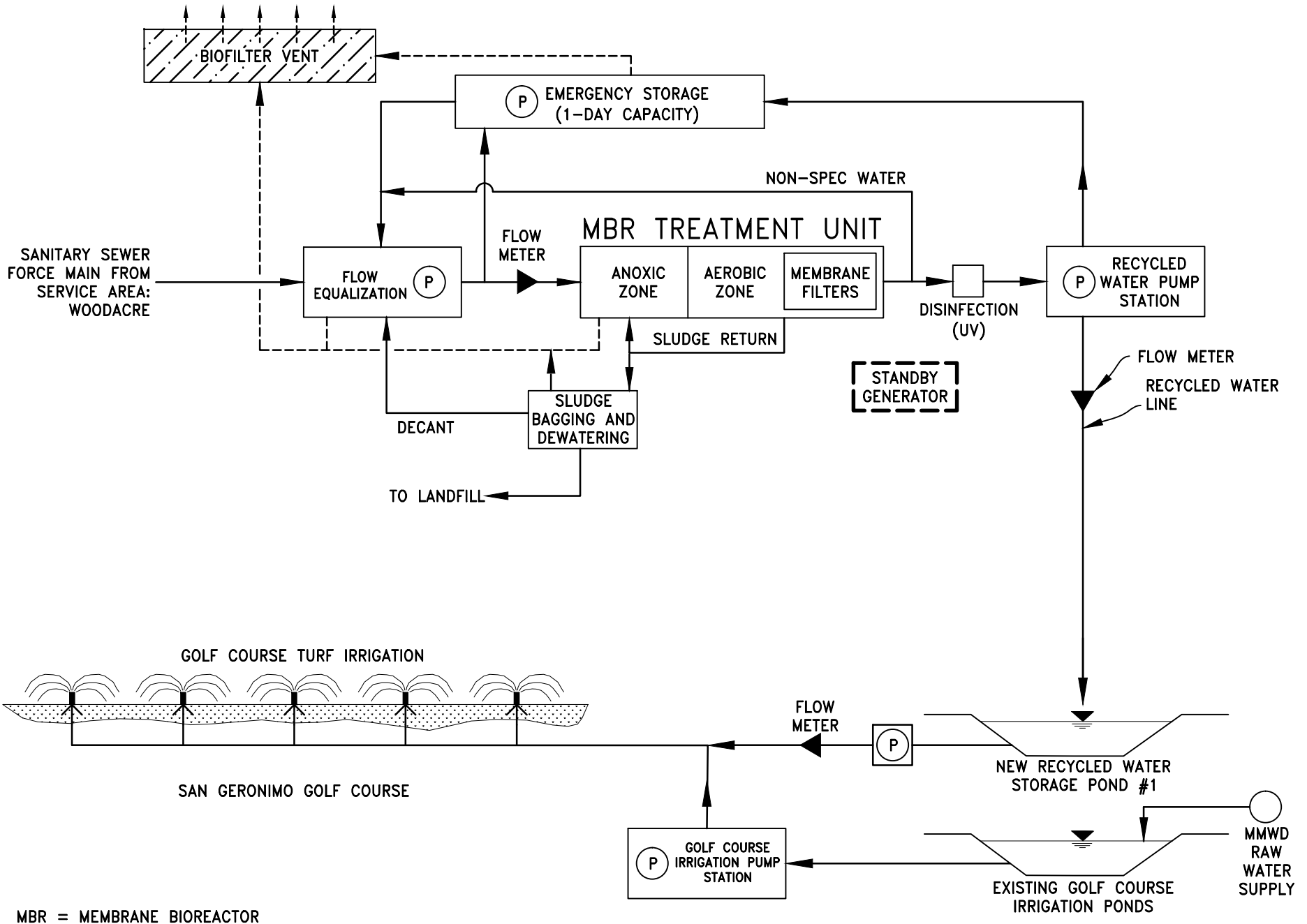

MBR = MEMBRANE BIOREACTOR

Site	Rev.	Date	By	Description	Appr'd

Design:	NH/MMW
Drawn:	DI
Checked:	NH
Appr'd:	NH

P:\3000\0011\WOODACRE\_SAN GERONIMO FLATS\WATER RECYCLING\SCHEMATIC\MBR\_TREATMENT\_UNIT\SCHEMATIC.dwg  
 DATE: 2/27/07  
 PAGE: 5 OF 5

- **Force Main Route A.** This route would follow San Geronimo Valley Drive. The force main would be installed within the road right-of-road, either beneath or immediately adjacent to the paved roadway. The force main would enter the golf course property at the existing maintenance access road approximately 300 feet north of Meadow Way, and then follow the access road to the treatment plant site on west side of the maintenance area. The force main would cross San Geronimo Creek on the existing road bridge where a ductile iron pipe sleeve would be provided for physical protection of the pipe and prevention/capture of any leakage. The total force main length for Route A is approximately 5,360 feet.
- **Force Main Route B:** This route would run north from the main lift station within the road rights-of way of Railroad Avenue, and then westerly along Sir Francis Drake Boulevard to the location of the San Geronimo Golf Course cart path undercrossing. At this point the pipeline would be routed across the golf course near green #8 to the treatment plant site on the west side of the maintenance area. The pipeline would be buried over its entire length, including where Railroad Avenue crosses San Geronimo Creek; here the pipeline would be installed beneath the road bed, above the concrete box culvert which contains the creek flow at this location. The total force main length for Route B is approximately 5,850 feet.

Analysis indicates force main Route B would be preferred over Route A based on negligible cost difference and reduced potential for impacts to San Geronimo Creek. Route B would put the pipeline a much greater distance from San Geronimo Creek along most of its length and would include a less vulnerable means for crossing of the creek – i.e., buried within the road bed of Railroad Avenue rather than sleeved and secured to the road bridge. For either pipeline route, the installation could be done using trenchless technology (horizontal directional drilling) to minimize traffic disruption and physical disturbance to road pavement.

### ***Wastewater Treatment***

The treatment facilities under this alternative would be designed and operated to produce disinfected tertiary water meeting the requirements of California Code of Regulations, Title 22 Water Recycling Criteria (see Section 5). Recycled water meeting these standards is acceptable for unrestricted landscape irrigation, including golf course irrigation, as well as other water recycling uses. (Note: the following discussion and diagrams regarding the wastewater treatment facility are also applicable to **Alternatives 4b** and **4c**, except as to the overall treatment system design capacity and sizing of unit processes.)

- **Treatment Plant Site.** **Figure 6-6** shows the location within the golf course maintenance area identified for placement of the wastewater treatment/recycling plant. It would be on the west side of the golf course maintenance yard, in an area previously graded and presently used for storage and processing of brush, cuttings and other green waste from the golf course. The proposed treatment plant site is outside of the Stream Conservation Area for San Geronimo Creek and naturally screened by several existing large trees and other vegetation, none of which would require removal. The proposed treatment plant site has good vehicular access from San Geronimo Valley Drive, and is in an area that avoids impacts to or from golf course play.

The treatment plant would occupy an area of approximately 10,000 square feet, including above and below ground tanks, blowers, pumps, piping, covered sludge

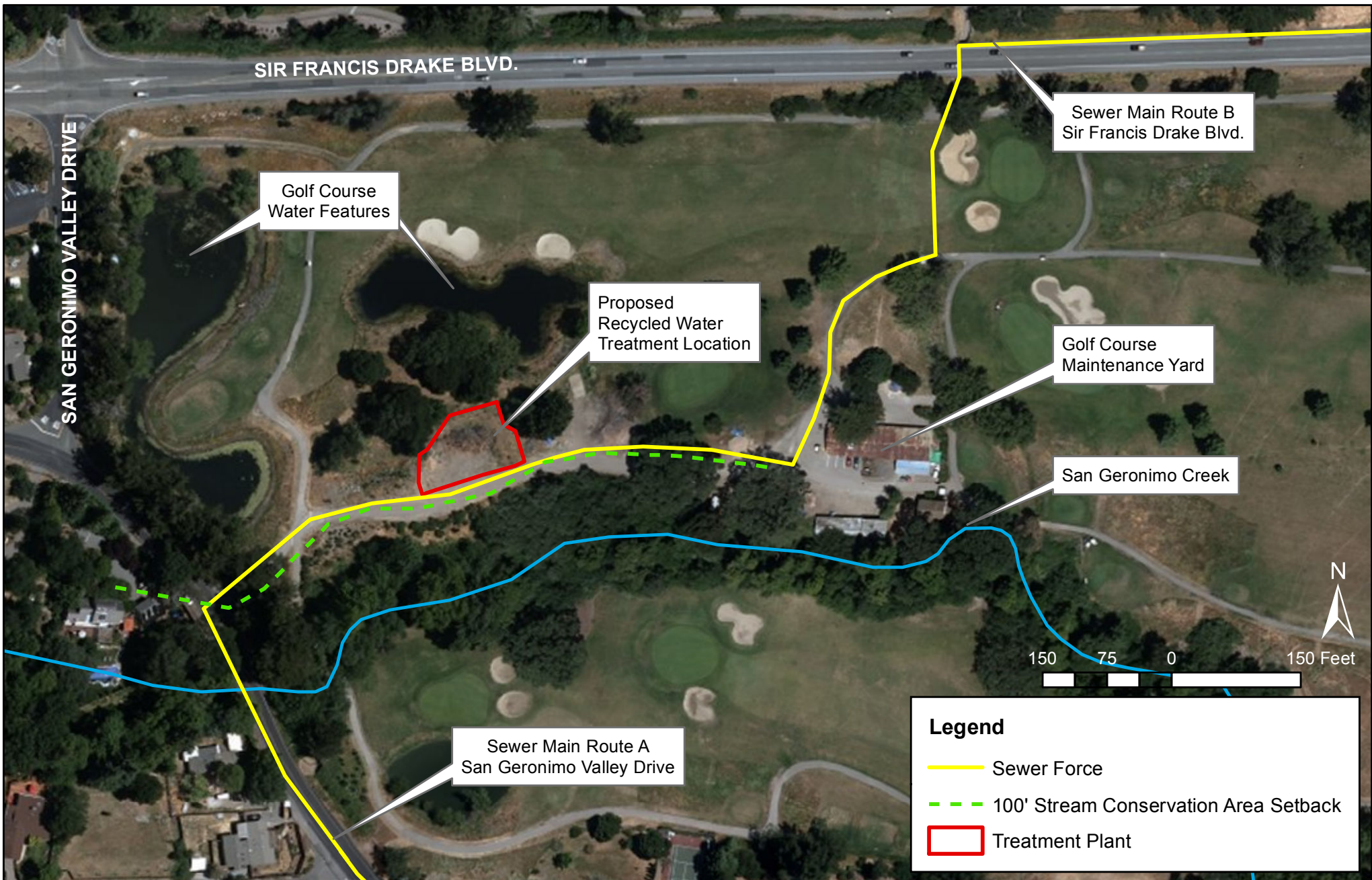

**Legend**

- Sewer Force
- - - 100' Stream Conservation Area Setback
- Treatment Plant

DATE:	2/26/2018
PROJECT:	WOODACRE WW
PROJECT NO.:	1600073
DRAWN:	DD
APPROVED:	NH



**RECYCLED WATER TREATMENT  
LOCATION - ALTERNATIVES  
4 (a, b & c)**

**FIGURE  
6-6**

dewatering and bagging area, biofilter venting and appurtenances. There would be a control building (approximately 600 ft<sup>2</sup>) to house electrical/mechanical controls, UV disinfection equipment, a small office, laboratory area, and storage space for equipment and supplies. The treatment plant area would have parking and vehicle access and would be fenced.

- **Title 22 Treatment System – Membrane Bioreactor.** Various types of treatment technologies, designs and manufacturers are available that can meet Title 22 water recycling requirements. The recommended system for this project is a membrane bioreactor (MBR), which is well suited because of the small area requirement, relatively low demands for operator control of the system (based on ease of automation), commercial availability, and acceptance of the technology by the State Water Board's Division of Drinking Water. Background information and technical details on the MBR treatment process (including advantages and disadvantages) are covered in an EPA Fact Sheet, which is provided in **Appendix E** along with example manufacturer information.

The facilities required for an MBR system to meet Title 22 water recycling criteria are diagrammed schematically in **Figure 6-5**. The MBR has small space requirements because it is designed to utilize a single complete mix reactor in which all the steps of the conventional activated sludge process occur with a membrane filter system submerged in the reactor.

Influent sewage enters the treatment plant in a flow-equalization (EQ) tank, which evens out the rate of sewage flow into the main treatment processes. From the EQ tank the raw sewage is pumped into the MBR treatment unit, consisting of an above-ground tank which includes an anoxic zone and aerated zone, pumps, electrically-actuated valves, blowers, level controls, a programmable logic controller (PLC) and ultra-filtration membrane filter. The sewage is mixed with recirculated mixed liquor in the anoxic cell and then flows to the aeration cell. In the aeration cell, the wastewater is aerated through a grid of fine bubble diffusers connected to positive displacement blowers. The ultra-filtration membranes are immersed directly in the aerated mixed liquor and are connected to the suction side of a centrifugal pump (or pumps). The clean permeate is drawn through the membranes and discharged to the disinfection system.

**UV Disinfection.** UV light disinfection is proposed and would be housed in the control building. The system would include dual units, capable of treating the entire flow with one unit out of operation. The selected equipment would be from among several types of UV systems listed and accepted by the DDW including performance validation report. Examples of approved UV systems are provided in **Appendix E**. Field testing of the UV system would be required at the time of installation to validate conformance with Title 22 disinfection/virus inactivation requirements.

**Sludge Handling.** Sludge would be withdrawn periodically from the MBR anoxic tank and collected in an adjacent, covered sludge bagging and dewatering area. Decant from the sludge dewatering tank would be collected and drained back to the EQ tank. The bagged sludge would be hauled for disposal at an approved sanitary landfill. Sludge bags, when filled, would be retained onsite in a covered area for several weeks of drying. Hauling of dry sludge (50-60 lb bags) would occur every few months.



**Odor Control.** Odor control facilities would be included, which are needed primarily in connection with the EQ tank, anoxic tank and sludge bagging/dewatering area. Odors would be controlled through capture and filtering through an organic media bed (biofilter) designed to remove volatile organic compounds, primarily hydrogen sulfide and methane. Activated carbon filters may be used at selected equipment locations, where practicable and if necessary.

**Other Facilities.** Other facilities necessary to satisfy Title 22 recycled water standards include: (a) standby emergency generator to operate the treatment plant during power outages; and (b) emergency storage sufficient to store at least one-day of incoming sewage flow from the service area. This would be provided by one or more large-capacity holding tanks (buried). Additionally, the treatment system would be equipped with automatic turbidity monitoring and control equipment that would temporarily interrupt and redirect the flow of treated water to the influent EQ tank in the event that effluent limits are exceeded or there is a malfunction of the UV disinfection system.

### ***Recycled Water Storage***

**Alternative 4a** would include the construction of a single recycled water storage pond (Pond #1), located as indicated in **Figure 6-4**, on the front nine of the golf course. The proposed location for the pond is a 2.5-acre triangular buffer area between the #2 green and #4 fairway, which was suggested and offered by the former golf course owners for this purpose. All recycled water would be pumped into this pond year-round, stored throughout the rainy season (typically November through March), and fed into the existing irrigation system during the golf course irrigation season, typically April through October.

**Figure 6-7** shows a preliminary pond layout and grading plan making maximum use of the available area. The pond would be constructed through a combination of excavation below existing grade (e.g., 6 to 12-feet deep) and engineered fill embankments above grade; all cut and fill slopes would be 2:1 (horizontal:vertical). For the configuration shown in **Figure 6-7**, the overall depth of the pond would be 20 feet, including capacity for water depth of 18 feet, plus two feet of freeboard. The total internal surface area of the pond would be approximately 1.7 acres.

Soil profile observations in the proposed pond area revealed a thin topsoil layer (12 to 18 inches) underlain by stiff clayey subsoils. These soil conditions are favorable for pond construction, and may be suitable material to be used in forming the required impermeable pond liner. If not, a geosynthetic clay liner such as "BENTOMAT" would be used for the pond liner. Drainage which presently flows overland in the pond area would have to be collected and re-routed. Portions of the irrigation pipeline that crosses through the pond area may require relocation. Fencing and landscaping around the pond would be provided.

Using the assumed pond configuration in **Figure 6-7**, water balance calculations (monthly time steps) were made to estimate the storage capacity, and corresponding water depth, needed to accommodate projected recycled water volumes plus direct rainfall for average, 10-year and 100-year rainfall amounts. Through iterative calculations, maximum capacity of the pond (under 100-year conditions) was determined to be 26,000 gpd. Calculations for average rainfall conditions provide an estimate of the typical volume of water that would be available for golf course irrigation. Rainfall amounts were estimated based on data from Woodacre Fire Station combined with long-term records from Kentfield and San Rafael for statistical determination of

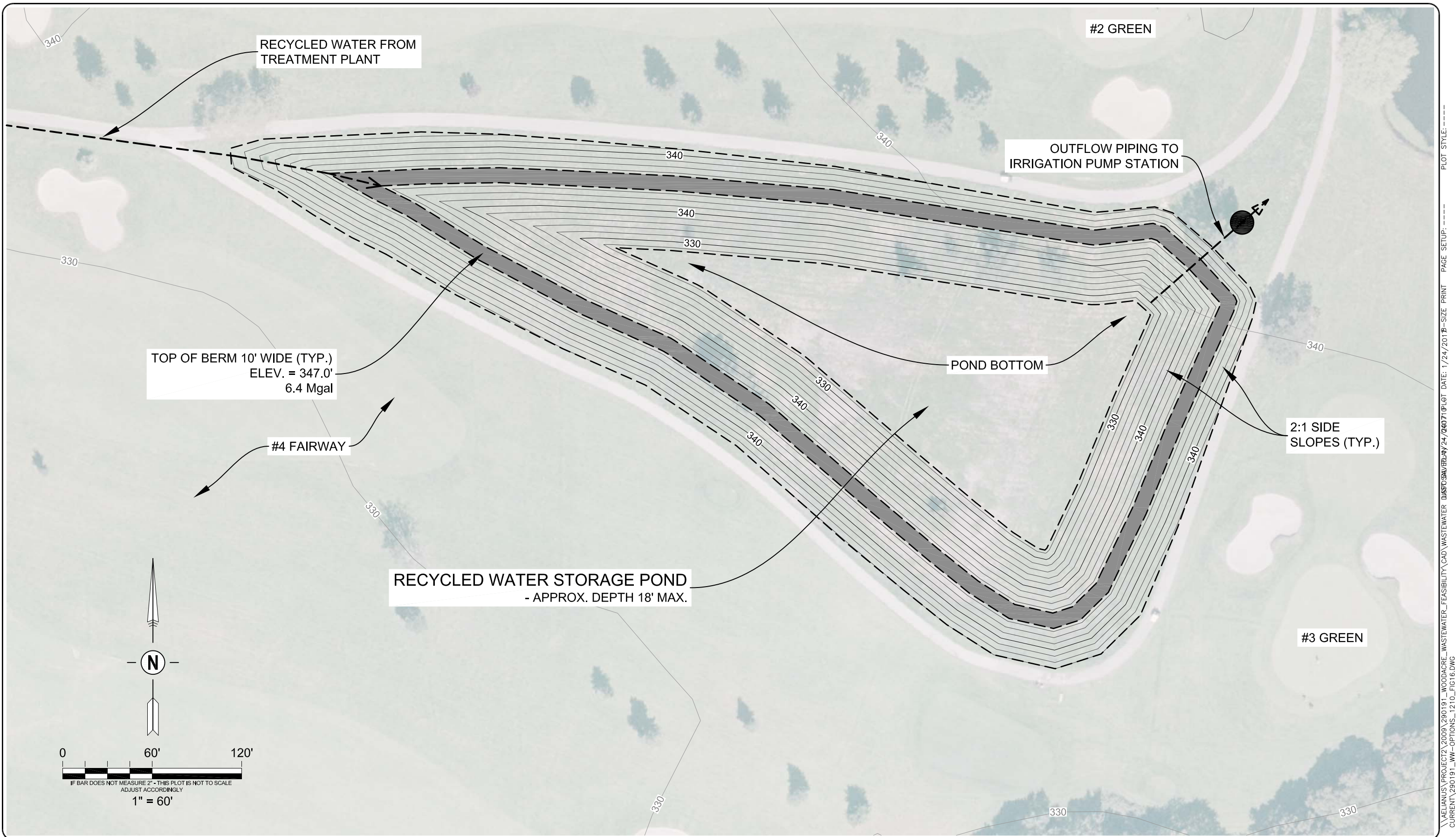

\LAELIANUS\PROJECTS\2009\290191\_WOODACRE\_WASTEWATER\_RECYCLING\FEASIBILITY\CAD\WASTEWATER\_DWG\DWG\RECYCLING\24\_040710\11.DWG DATE: 1/24/2011 PAGE SETUP: 1/24/2011 PLOT STYLE:

**WOODACRE -SAN GERONIMO  
WASTEWATER RECYCLING STUDY**



Sht:	Rev:	Date:	By:	Description:	App'd:

Design: NH/MW  
 Drawn: AM/DI  
 Checked: NH  
 Appr'd: NH

**RECYCLED WATER STORAGE  
STORAGE POND #1**

**FIGURE  
6-7**

10-yr and 100-yr rainfall amounts. Water balance spreadsheet calculations and rainfall statistics are provided in **Appendix F**. Results are summarized in **Table 6-8**.

**Table 6-8. Water Balance Summary for Recycled Water Storage Pond #1, Alternative 4a**

Ave Wet Weather Wastewater Flow (gpd)	Rainfall Scenario	Max Pond Water Depth Reached (ft)	Annual Recycled Water Produced for Irrigation	
			Million Gals	Acre-Feet
26,000	Average	14.0	9.2	28.8
26,000	10-yr	15.5	10.1	31.0
26,000	100-yr	18.0	10.8	33.1

### ***Irrigation Disposal Facilities***

During the dry season (typically April-October), the water from the storage ponds would be integrated into the main irrigation water supply for the golf course, which presently comes from MMWD. The recycled water would be discharged directly into the irrigation system near the existing pump station located behind the #2 green. This irrigation pump station is designed to draw water from the existing golf course pond in front of the #3 tee, which is fed by a raw water pipeline from MMWD. The recycled water would not mix with the golf course pond water.

Annual irrigation water demand for the golf course varies between approximately 47 and 53 million gallons, depending on weather conditions. On average, recycled water produced under **Alternative 4a** would be able to supply about 18 percent of the irrigation demand.

The golf course would have to comply with recycled water use area requirements, per Title 22 requirements outlined in Section 5. These cover items such as signage and markings, protection of drinking water fountains and outdoor eating areas, setbacks from wells, prevention of runoff and spray drift, and protection against cross-connection with domestic water lines.

### **Operation and Maintenance Requirements**

The wastewater facilities described under this alternative would require maintenance by a California certified wastewater treatment plant operator (minimum Grade III). This would cover operation, maintenance, and monitoring responsibilities for the collection system and the treatment plant. Golf course personnel, considered the recycled water “User”, would be responsible for maintenance and operation of the storage ponds, irrigation pump and distribution system and the recycled water uses areas (i.e., the golf course turf areas).

System maintenance would include regular inspection of all equipment and processes. A telemetry system would be incorporated to facilitate remote, continuous monitoring of the critical elements of the pump stations and the treatment system. Ongoing inspection and maintenance of the wastewater treatment facility and collection system is anticipated to include on-site physical work several days a week.

Effluent water quality sampling and analysis would be an important aspect of the ongoing operation and maintenance of the MBR system and would be required for permit compliance under terms of the Monitoring and Reporting Program established by the Regional Water Board. This would include daily sampling and analysis for coliform bacteria per Title 22 water recycling requirements. Contract arrangements with MMWD for coliform testing at their San Geronimo Water Treatment Plant would be an efficient way to meet this critical operating requirement. Sampling and analysis of recycled water for “Priority Pollutants”<sup>2</sup> would be required once every five years.

The holding ponds would be a relatively passive system requiring periodic inspection and upkeep, but little in the way of day-to-day operational requirements. The pond water levels would require management to assure suitable capacity for wet weather storage needs; pond maintenance also requires implementation of mosquito control measures, normally consisting of application of microbial larvicides that are registered and approved for use by the US EPA. Pond operation and maintenance would be handled by the golf course maintenance personnel, as would the irrigation pump station and spray operations.

Since the treated water would be incorporated into the existing golf course irrigation system for dry season application to existing managed turf areas, monitoring would primarily consist of visual observations of use areas, noting and correcting any evidence of ponding or runoff of irrigation water, and other abnormal conditions. Water quality sampling of the few streams that traverse the golf course may be required. Groundwater monitoring is unlikely to be required.

All flow monitoring, influent and effluent water quality data, storage pond levels and conditions, sludge hauling volumes, and wastewater treatment and water recycled water system inspection reports would be prepared and submitted to the San Francisco Bay Regional Water Board according to a schedule prescribed by the Monitoring and Reporting Program. Monthly and annual reporting frequency is anticipated. Annual monitoring data pertaining to the water recycling operations would also be submitted to the DDW.

## **Estimated Costs**

### ***Capital Costs***

The estimated capital costs for **Alternative 4a** are presented in **Table 6-9**, showing the costs for the two alternate force main routes, A and B. The bottom line in the table converts the total project costs to the average cost per connection, based on 210 parcels that would be served. Detailed itemization of costs is provided in **Appendix H**, including quantities and unit cost assumptions. These assumptions were developed through discussions with manufacturers, equipment suppliers, and local contractors, and through review of recent contractor bids for similar work in Marin County, where applicable. Included are all expected costs for new gravity and pressure sewers, lift station and transmission line to the golf course, MBR treatment system, recycled water storage pond on the golf course, and connections to the golf course irrigation pumping system. Also included is a contingency 10% allowance, as well as estimated costs for engineering design, environmental studies, construction management, project administration, district formation and financing. The estimated total project cost is approximately \$9.6 million with an approximate cost of \$45,600 per parcel served. The cost difference between force main route A and B is negligible.

---

<sup>2</sup> Priority Pollutants refer to a list of 126 specific pollutants that includes heavy metals and specific organic chemicals.

## Operation and Maintenance Costs

The estimated annual operation and maintenance costs for **Alternative 4a** are provided in **Table 6-10**, with supporting itemized calculations and assumptions provided in **Appendix H**. The O&M cost are estimated based on labor, equipment, materials and other expenses required to perform the necessary inspections, water quality sampling, data analysis, report preparation, sludge disposal, and routine maintenance for the collection system and MBR treatment/recycling plant. Not included are any costs associated with the storage and use of the recycled water by the golf course for turf irrigation. Also included are estimates of annual energy costs (electrical) for operation of the main lift station and the treatment system. O&M costs include an allowance for equipment repair/replacement, which would be required over the life of the system. An allowance of 10% is included as a contingency. The cost estimates were developed based on the expected operation and monitoring needs defined above, and using data and experience from monitoring and maintenance of other similar systems in Marin County and other Northern California communities. The total annual O&M cost is estimated to be about \$291,500, with a per parcel annual cost of \$1,356.

**Table 6-9. Estimated Capital Costs – Alternative 4a**

Cost Item	Route A - Cost (\$)	Route B - Cost (\$)
Collection System (Gravity Sewer)*	4,063,175	4,067,575
Tertiary Treatment Plant	1,180,000	1,180,000
Recycled Water Storage & Transmission	1,004,000	1,004,000
Land/Easement Costs	0	0
Mobilization/Demobilization	100,000	100,000
Permit Fees & Encroachment Fees	50,000	50,000
<b>Subtotal</b>	<b>\$6,397,175</b>	<b>\$6,401,575</b>
Contingency @ 15%	\$959,576	\$960,236
<b>Subtotal</b>	<b>\$7,356,751</b>	<b>\$7,361,811</b>
Engr & Environ Studies @ 15%	\$1,103,513	\$1,104,272
Construction Management @ 10%	\$735,675	\$736,181
Admin, Dist Formation, Financing @ 5%	\$367,838	\$368,091
<b>Total Estimated Cost</b>	<b>\$9,563,777</b>	<b>\$9,570,355</b>
<b>Estimated Cost Per Connection</b>	<b>\$45,542</b>	<b>\$45,573</b>

\* Does not include individual property owner cost for septic tank abandonment and on-lot work to connect house plumbing to new sewer system, typical range of \$1,500 to \$3,000.

**Table 6-10. Estimated Annual O&M Costs – Alternative 4a**

Category	Items	Cost (\$)
<b>District/Program Administration</b>	Insurance, legal, financial, administration	12,000
	RWQCB Permits	10,000
<b>Labor – Collection &amp; Treatment</b>	Systems Control Technician	12,000
	Grade III Operator	46,800
	Grade I Operator	39,000
	Field Technician	31,200
	Engineering Consultation	12,000
	On-call Monitoring & Response Allowance	12,000
<b>Sludge Handling</b>	Bagging, Materials and Disposal Fees	3,600
<b>Sewer Lines</b>	Maintenance Cleaning	4,000
<b>Equipment</b>	Materials & Replacement	27,000
<b>Vehicle</b>	Lease and mileage	4,800
<b>Laboratory and Expenses</b>	Laboratory	21,600
	Cleaning Chemicals & Supplies	3,000
<b>Electrical</b>	Lift Station	660
	MBR Treatment Plant	20,188
	UV Disinfection	2,294
	Treated Water Distribution	2,294
	Misc electrical, phone, internet	600
<b>Sub-total</b>		<b>\$265,037</b>
10% Contingency		\$26,503
<b>Estimated Total Annual Cost</b>		<b>\$291,540</b>
<b>Estimated Annual Cost per Connection (365 ESDs<sup>1</sup>)</b>		<b>\$1,356</b>

<sup>1</sup> Includes additional allowance of 5 ESDs for service to golf course clubhouse

## **Alternative 4b – Woodacre & San Geronimo - Partial Service, 270 Parcels**

This alternative would be an expansion of **Alternative 4a**, including wastewater service to approximately 75% of the developed properties in both Woodacre and San Geronimo. It would include wastewater collection facilities throughout both communities, with the assumption that approximately 270 of the property owners would opt to connect to the system. Those not connecting would continue to be served by their existing/improved onsite septic systems.

**Alternative 4b** would include all wastewater facilities described in **Alternative 4a**, with the following changes and additions:

- **Collection System.** The wastewater collection system in San Geronimo would consist of (a) pressure sewers with individual grinder pumps at each property; and (b) pressure sewer force mains installed in Sir Francis Drake Boulevard, San Geronimo Valley Drive and Meadow Way, connecting at the western driveway entrance into the golf course maintenance area.
- **Treatment System.** The tertiary treatment plant would be expanded to provide a nominal capacity of 40,000 gpd (45,000 gpd peak flow), including upsizing tanks, pumps

and other equipment as needed. Estimated average daily wastewater flow (wet season) for this alternative is 33,200 gpd.

- **Storage Pond #2 (Lower half).** A second recycled water storage Pond #2 (Lower half) would be constructed adjacent to the #18 fairway on the back nine of the golf course.
- **Transmission Lines.** A second recycled water transmission line would be installed, running from the treatment plant to Pond #2, a distance of approximately 3,500 feet. Additionally there would be an inter-tie and pumping facilities, allowing water transfer from Pond #1 to Pond #2 for distribution into the golf course irrigation system.
- **Irrigation Pump Station.** A new irrigation pump station would be installed at Pond #2 designed to pump all recycled water directly from Pond #2 into the adjacent irrigation main line, integrated with the existing golf course irrigation control system.

## Alternative 4c – Woodacre & San Geronimo - Full Service, 360 Parcels

This alternative is an expanded version of **Alternative 5a**, with facilities sized to provide service to essentially all 360 developed properties in the Woodacre and San Geronimo communities. The expanded capacity would be achieved by the following:

- **Treatment Plant Capacity.** The tertiary treatment plant would be expanded to provide a capacity of 50,000 gpd, including upsizing tanks, pumps and other equipment as needed. Estimated average daily wastewater flow (wet season) for this alternative is 44,000 gpd.
- **Full-size Pond #2.** Recycled water storage Pond #2 would be constructed to the full (maximum) capacity that can be accommodated in the available area.

**Alternative 4c** would maximize the system capacity that can be provided based on largest feasible sizing of Ponds #1 and #2 for wet season storage.

**Figure 6-10** shows a preliminary pond layout and grading plan for Pond #2, making maximum use of the available area. Pond #2 would be divided into two sections, Upper and Lower, to conform with existing topography. It would be constructed through a combination of excavation below existing grade (e.g., 6 to 12-feet deep) and engineered fill embankments above grade; all cut and fill slopes would be 2:1 (horizontal:vertical). For the configuration shown in **Figure 6-10**, the overall depth of the pond would be 15 feet, including capacity for water depth of 15 feet, plus two feet of freeboard. The total internal surface area of the pond would be approximately 2.7 acre, with an estimated storage capacity of 5.9 million gallons (18.1 acre-feet). Drainage measures would be installed to collect and re-route surface and subsurface waters around the ponds. Drainage work would require removal of an existing 18-inch storm drain culvert and smaller sub-drains, with most of the flow re-routed to a new vegetated drainage swale on the south side of the new pond. Portions of irrigation pipelines that cross through the pond areas may require relocation.

Using the assumed pond configurations for Pond #1 and Pond #2 (**Figures 6-7** and **6-10**) water balance calculations (monthly time steps) were made to estimate the storage capacity, and corresponding water depth, needed to accommodate projected recycled water volumes plus

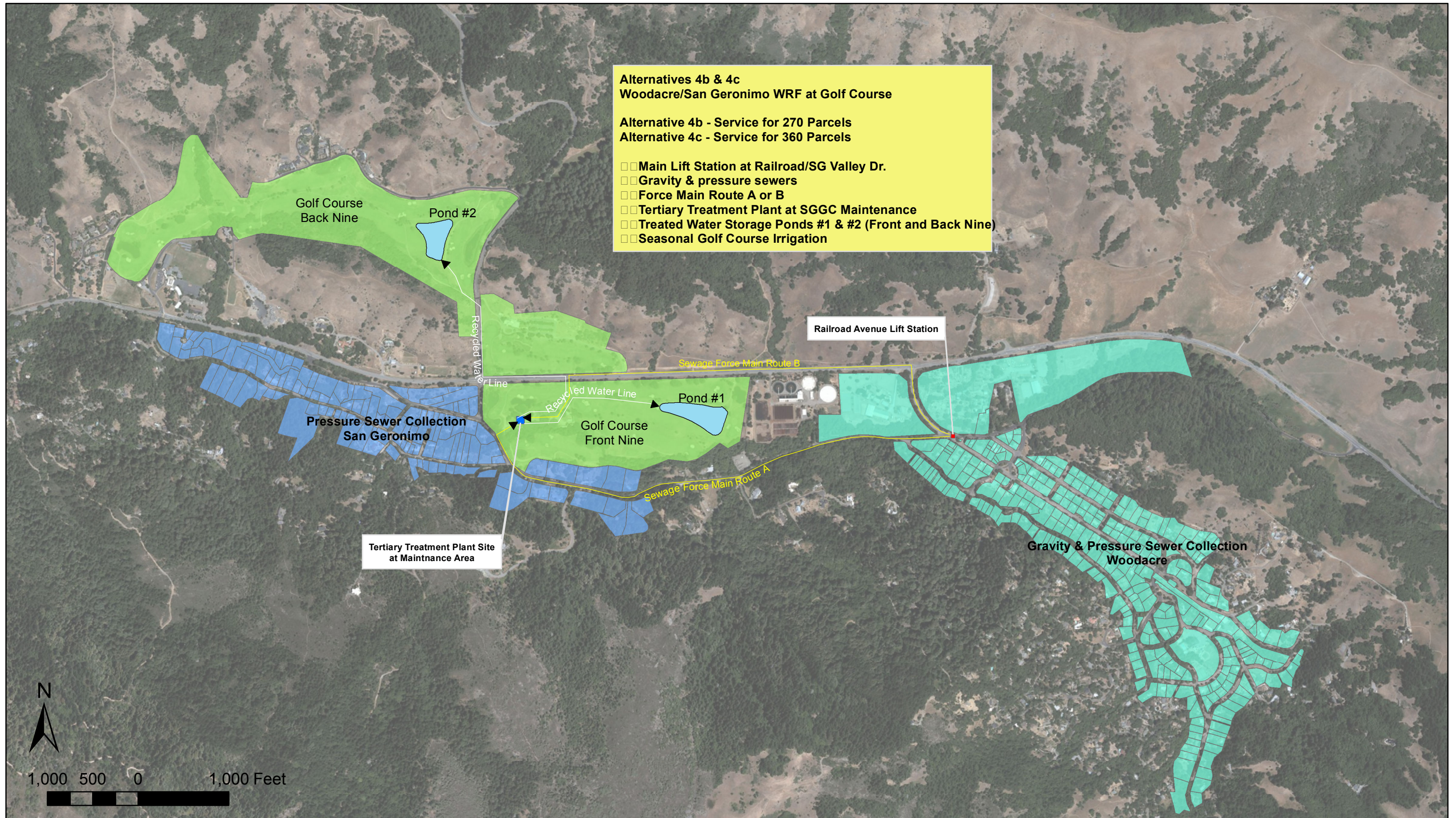

DATE:	2/7/2019
PROJECT:	WOODACRE WW
PROJECT NO:	1600073
DRAWN:	MF
APPROVED:	NH



## ALTERNATIVES 4b & 4c

**FIGURE  
6-8**



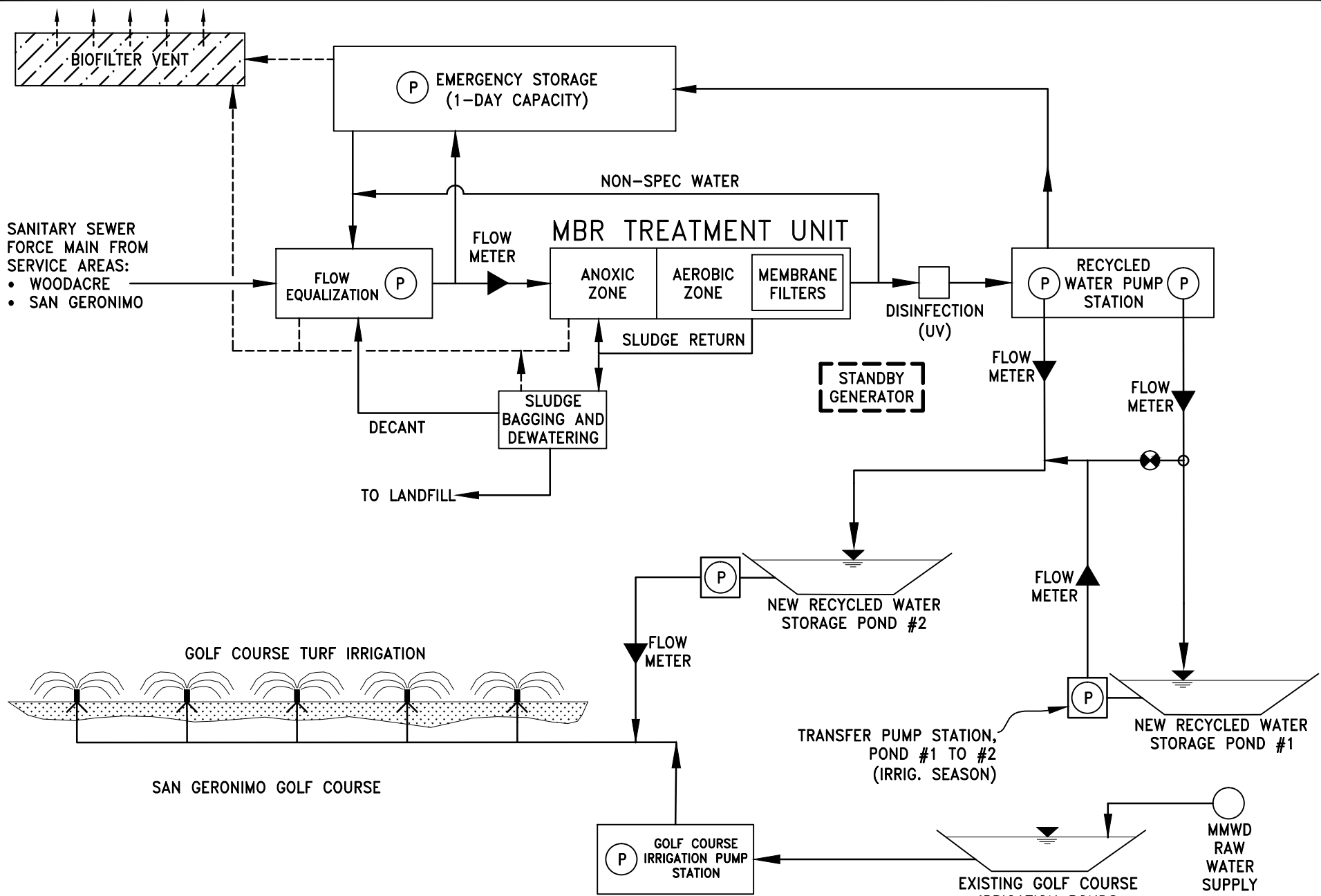

MBR = MEMBRANE BIOREACTOR

Site	Rev.	Date	By	Description	Appr'd

Design:	NH
Drawn:	MF
Checked:	NH
Appr'd:	NH

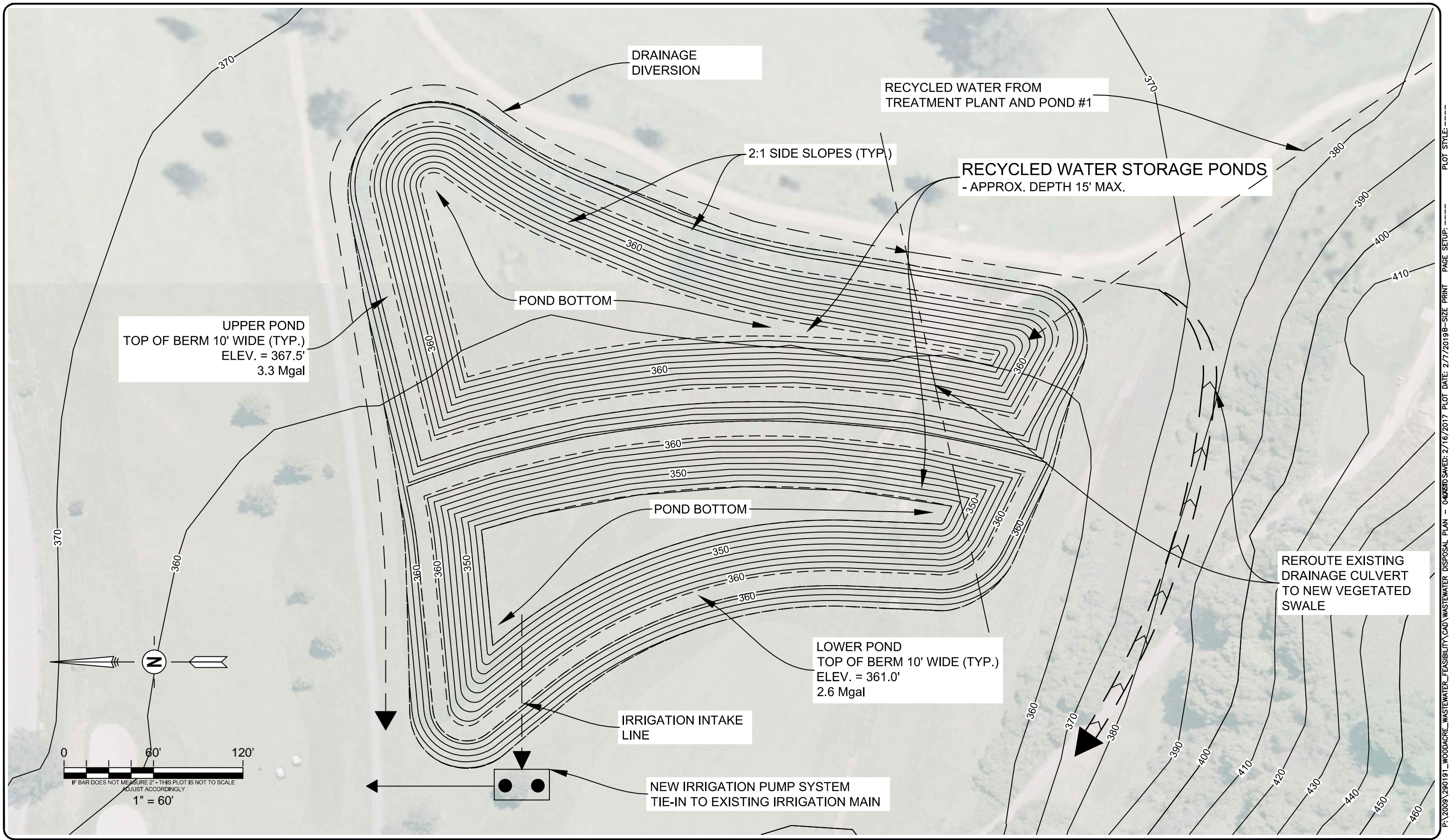

P:\2009\290191\_WOODACRE\_WASTEWATER\_FEASIBILITY\CAD\WASTEWATER\_DISPOSAL\_PLAN - 0406510.SAVED: 2/16/2017 PLOT DATE: 2/7/2018-SIZE PRINT PAGE SETUP: ----- PLOT STYLE: -----

**WOODACRE - SAN GERONIMO  
WASTEWATER RECYCLING STUDY**



Sht:	Rev:	Date:	By:	Description:	App'd:

Design: NH/MW  
 Drawn: AM/DI  
 Checked: NH  
 App'd: NH

**RECYCLED WATER STORAGE  
STORAGE POND #2**

FIGURE  
**6-10**

direct rainfall for average, 10-year and 100-year rainfall amounts. Through iterative calculations, maximum capacity of the ponds (under 100-year conditions) were determined and are summarized in **Table 6-11** along with respective dimensions and earthwork estimates. Calculations for average rainfall conditions provide an estimate of the typical volume of water that would be available for golf course irrigation. Rainfall amounts were estimated based on data from Woodacre Fire Station combined with long-term records from Kentfield and San Rafael for statistical determination of 10-yr and 100-yr rainfall amounts. Water balance spreadsheet calculations and rainfall statistics are provided in **Appendix F**.

**Table 6-11. Recycled Water Storage Ponds #1 and #2**

Item		Pond #1	Pond #2 Upper	Pond #2* Lower	Total
<b>Overall Land Area (ft<sup>2</sup>)</b>		123,350	71,030	63,250	257,630
<b>Interior Surface Area (ft<sup>2</sup>)</b>		74,650	49,480	41,100	165,230
<b>Excavation (cy)</b>	<b>Cut</b>	14,580	18,870		33,450
	<b>Fill</b>	18,180	10,490		28,670
<b>Max. Water Depth (ft)</b>		18.0	15.0	15.0	-
<b>Water Storage Capacity</b>	<b>Million Gals.</b>	6.45	3.30	2.60	12.35
	<b>Acre-Feet</b>	19.8	10.1	8.0	37.9
<b>100-yr Wastewater Holding Capacity, gpd</b>		26,000	10,200	7,800	44,000

\* Alternative 4b includes Pond #2 Lower; Alternative 4c includes Pond #2 Upper and Lower

For the recommended pond configurations and sizing and the estimated average wet weather wastewater flows (33,200 **Alternative 4b**, 44,000 gpd **Alternative 4c**), water balance calculations for average year, 10-year and 100-year rainfall amounts were completed to estimate the amount of recycled water that would be produced for use by the golf course. The results for average year conditions (long-term average) are summarized in **Table 6-12**. The table also lists the previous estimates for **Alternative 4a**, which includes the use of Pond #1 only. Supporting calculations are provided in **Appendix F**. As indicated, the recycled water produced by the three options ranges from about 18% to 33% of the annual water historically used for golf course irrigation. During dry years, the recycled water contribution could decline by 10% or more of the percentages indicated in **Table 6-12**, partly due to lower rainfall addition to the storage ponds, and partly due to higher irrigation demand during dry years.

**Table 6-12. Recycled Water Produced – Average Annual Volumes<sup>1</sup>**

Alternative	Recycled Water Produced per		Percent of Golf Course Irrigation Demand <sup>2</sup>
	Acre-feet	Million gals	
<b>Alternative 4a</b>	28.8	9.2	18%
<b>Alternative 4b</b>	37.6	12.3	25%
<b>Alternative 4c</b>	50.0	16.3	33%

<sup>1</sup> For average annual rainfall year (41.6")

<sup>2</sup> Based on average irrigation demand of 50 million gals/yr

## Estimated Costs

### Capital Costs

The estimated capital costs for **Alternatives 4b** and **4c** are presented in **Table 6-13**, including wastewater collection, tertiary treatment plant, water recycling storage, transmission and pumping facilities, along with a contingency factor and estimated implementation costs. As indicated, the total estimated project costs are \$12.65 million for **Alternative 4b** and \$14.3 million for **Alternative 4c**. The bottom line in the table converts the total project costs to the average cost per connection, showing costs of about \$46,900 for **Alternative 4b** and \$39,800 for **Alternative 4c**. Detailed itemization of costs is provided in **Appendix H**, including quantities and unit cost assumptions.

**Table 6-13. Estimated Capital Costs - Alternatives 4b & 4c**

Cost Item	Alternative 4b 270 Parcels	Alternative 4c 360 Parcels
Collection System – Woodacre (Route A)*	\$3,921,375	4,224,175
Collection System – San Geronimo*	\$1,486,800	1,811,100
Tertiary Treatment Plant	\$1,330,000	1,470,000
Recycled Water Storage & Transmission	\$1,575,000	1,925,000
Land/Easement Costs	-	-
Mobilization/Demobilization	100,000	100,000
Permit Fees & Encroachment Fees	50,000	50,000
<b>Subtotal</b>	<b>\$8,463,175</b>	<b>\$9,580,975</b>
Contingency @ 15%	\$1,269,476	\$1,437,146
<b>Subtotal</b>	<b>\$9,732,651</b>	<b>\$11,018,121</b>
Engineering & Environmental Studies @ 15%	\$1,459,898	\$1,652,718
Construction Management @ 10%	\$973,265	\$1,101,812
Project Admin, Dist Formation, Financing @ 5%	\$486,633	\$550,906
<b>Total Estimated Cost</b>	<b>\$12,652,447</b>	<b>\$14,323,558</b>
<b>Estimated Cost Per Connection</b>	<b>\$46,861</b>	<b>\$39,788</b>

\* Does not include individual property owner cost for septic tank abandonment and on-lot work to connect house plumbing to new sewer system, typical range of \$1,500 to \$3,000.

### Operation and Maintenance Costs

Estimated annual operation and maintenance costs for **Alternatives 4b** and **4c** are provided in **Table 6-14**, with supporting itemized calculations and assumptions provided in **Appendix H**. The O&M cost are estimated based on labor, equipment, materials and other expenses required to perform the necessary inspections, water quality sampling, data analysis, report preparation, sludge disposal, and routine maintenance for the collection system and MBR treatment/recycling plant. Not included are any costs associated with the storage and use of the recycled water by the golf course for turf irrigation. Also included are estimates of annual energy costs (electrical) for operation of the main lift station and the treatment system. O&M costs include an allowance for equipment repair/replacement, which would be required over the life of the system. An allowance of 10% is included as a contingency. As indicated, the total estimated annual O&M costs are about \$346,500 for **Alternative 4b** and \$366,500 for **Alternative 4c**. The resulting annual cost per parcel would be approximately \$1,260 for **Alternative 4b** and \$1,000 for **Alternative 4c**.

**Table 6-14. Estimated Annual O&M Cost – Alternatives 4b and 4c**

Category	Items	Alternative 4b Cost (\$)	Alternative 4c Cost (\$)
<b>District/Program Administration</b>	Insurance, legal, financial, administration	12,000	18,000
	RWQCB Permit	10,000	10,000
<b>Labor Collection &amp; Treatment</b>	Systems Control Technician	12,000	14,000
	Grade III Operator	46,800	46,800
	Grade I Operator	39,000	57,000
	Field Technician	45,600	45,600
	Engineering Consultation	12,000	15,000
	On-call Monitoring & Response Allowance	12,000	12,000
<b>Sludge Handling</b>	Bagging, Materials and Disposal Fees	3,600	3,600
<b>Sewer Lines</b>	Maintenance Cleaning	6,000	6,000
<b>Equipment</b>	Materials & Replacement	54,000	54,000
<b>Vehicle</b>	Lease and mileage	4,800	4,800
<b>Laboratory and Expenses</b>	Laboratory	24,000	24,000
	Cleaning Chemicals & Supplies	3,000	3,600
<b>Electrical</b>	Lift Station	660	660
	MBR Treatment Plant	23,492	29,365
	UV Disinfection	2,753	3,212
	Treated Water Distribution	2,753	3,212
	Misc electrical, phone, internet	\$600	600
<b>Sub-total</b>		<b>\$315,058</b>	<b>\$333,149</b>
10% Contingency		\$31,506	\$33,315
Estimated Total Annual Cost		<b>\$346,564</b>	<b>\$366,463</b>
<b>Estimated Annual Cost per Connection<sup>1</sup></b>		<b>\$1,260</b>	<b>\$1,004</b>

<sup>1</sup> Includes additional allowance of 5 ESDs for service to golf course clubhouse

## **ALTERNATIVE 5 – WATER RECYCLING SYSTEM WITHOUT PONDS**

**Alternative 5**, with three variations (**a**, **b** and **c**), is similar to **Alternative 4**, but without the use of winter holding ponds for storage of recycled water. Other differences are that **Alternative 5** proposes to locate the treatment facility on the Clubhouse Parcel rather than in the maintenance area, and includes subsurface drip dispersal of treated water during the wet season in lieu of holding ponds. **Alternative 5** could still accommodate a golf course use on the property, but it could alternatively supply recycled water to meet significant water demands of new potential uses of the golf course property.

## Alternative 5a – Woodacre Service Only, 210 Parcels

### Description

This alternative corresponds generally with **Alternative 4a**, providing for a water recycling facility located at the golf course property. It would provide capacity to serve up to an estimated 250 parcels in the Woodacre portion of the study area. It would entail the following: (a) construction of a central wastewater collection system in the Woodacre service area; (b) wastewater transmission line to the San Geronimo Golf Course property via San Geronimo Valley Drive or Sir Francis Drake Boulevard (preferred route); (c) tertiary treatment plant (35,000 gpd capacity) located at one of three potential sites in the golf course clubhouse area; (d) pump station and buried tanks for short-term storage and regulation of recycled water for irrigation uses or drip dispersal; (e) seasonal reuse of the recycled water for surface irrigation of landscaping, turf grass, open space, and habitat restoration areas on the Clubhouse Parcel or other portions of the golf course property (approximately 6.5 acres); and (f) sub-surface drip dispersal of the recycled water during the wet weather season, or at other times in lieu of surface irrigation use; approximately 1.8 acres of drip dispersal areas would be developed in portions of the Clubhouse Parcel. The wastewater would be treated to meet State requirements for disinfected tertiary recycled water, and would be used to fully replace or reduce the amount of raw water that has historically been supplied to the golf course property from MMWD. The system would have a capacity to accommodate an estimated average daily flow of approximately 30,800 gpd and wet weather peak flow of 40,000 gpd. Under average year conditions, the project would produce approximately 18 acre-feet (5.9 million gallons) of recycled water for landscape irrigation on the Clubhouse property during the normal summer irrigation season, and a total annual recycled water volume of approximately 32.4 acre-feet (10.6 million gallons) for irrigation and other uses developed locally for disinfected tertiary treated recycled water.

**Figure 6-11** is a map showing the location of key features of **Alternative 5a**, also applicable to **Alternatives 5b** and **5c** with variations, as noted. **Figure 6-12** provides an overall schematic of the wastewater treatment and recycling system for **Alternatives 5a, 5b** and **5c**.

As compared with water recycling **Alternative 4a** presented above, **Alternative 5a** allows for a change in use and new opportunities for the golf course property, such as habitat restoration, parks, open space, event center, and other public/community services. It also retains the option to use recycled water to irrigate the golf course, although the amount of available water would be less. Other differences compared with **Alternative 4a** are:

- 1) The recycled water treatment plant is proposed to be located at one of three potential sites near the Clubhouse facilities, rather than in the golf course maintenance area.
- 2) There will be no winter holding ponds for storage of treated/recycled water.
- 3) During the normal irrigation season (April-October), recycled water will be provided for surface irrigation of approximately 6.5 acres of landscaping and turf grass on the Clubhouse Parcel.

- Alternative 5**  
**Water Recycling Facility at Golf Course Property, Without Storage Ponds**  
 5a – Woodacre Only, 250 Parcels  
 5b – Woodacre + San Geronimo @ 75% – 270 Parcels  
 5c – Woodacre + San Geronimo @ 100% - 360 Parcels
- Gravity and Pressure Sewers
  - Main Lift Station at Railroad/S.G. Valley Dr
  - Force Main Route A or B
  - Tertiary Treatment Plant near Golf Course Clubhouse (Site A, B or C)
  - Summer - Seasonal Irrigation of Landscaping, Open Space and/or Golf Course
  - Winter - Drip Dispersal of Treated Water in Road R/W and Clubhouse Area
  - Other Incidental Recycled Water Uses

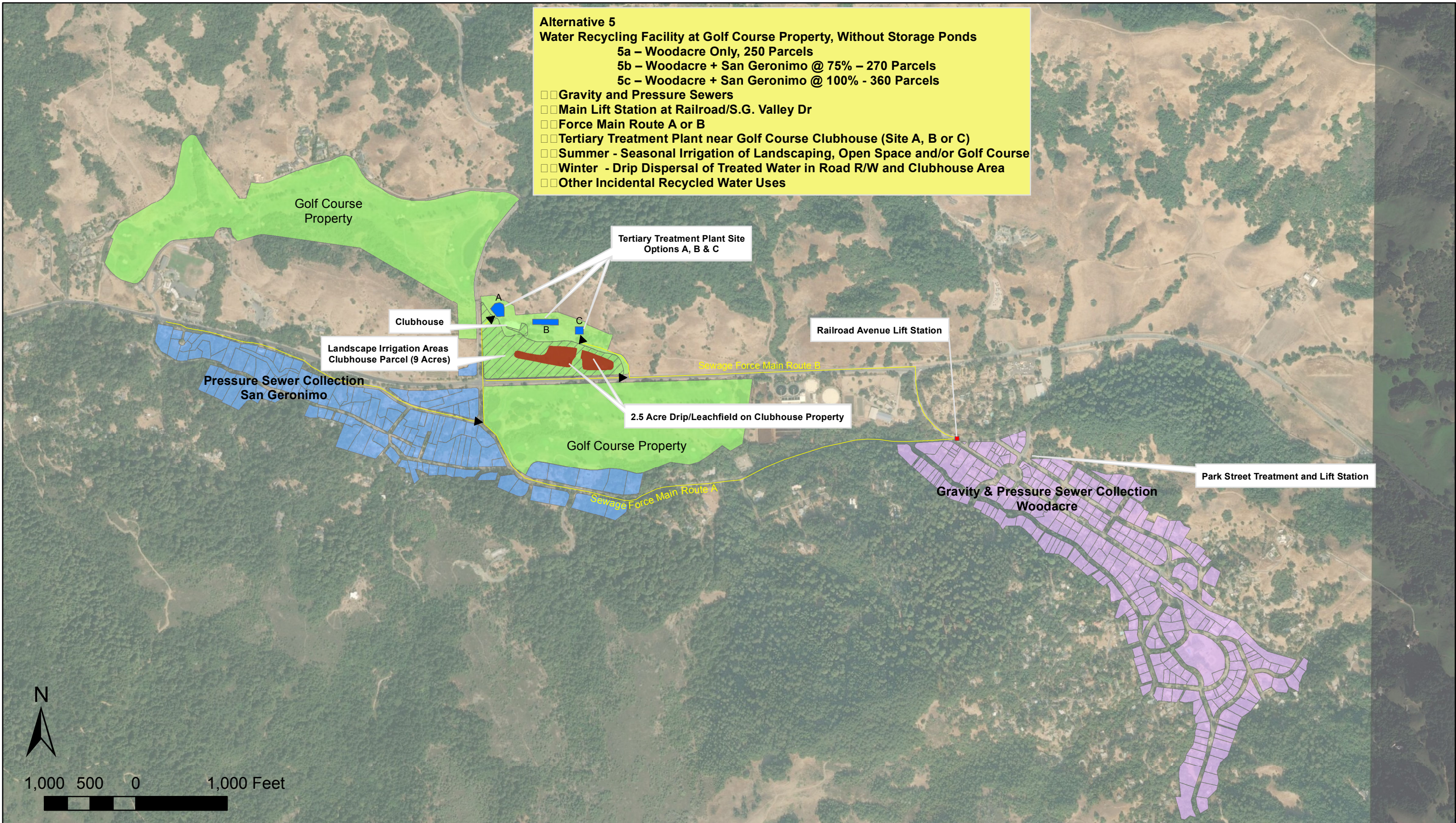

DATE:	2/7/2019
PROJECT:	WOODACRE WW
PROJECT NO:	1600073
DRAWN:	MF
APPROVED:	NH



## WATER RECYCLING ALTERNATIVES 5a, 5b & 5c

FIGURE 6-11

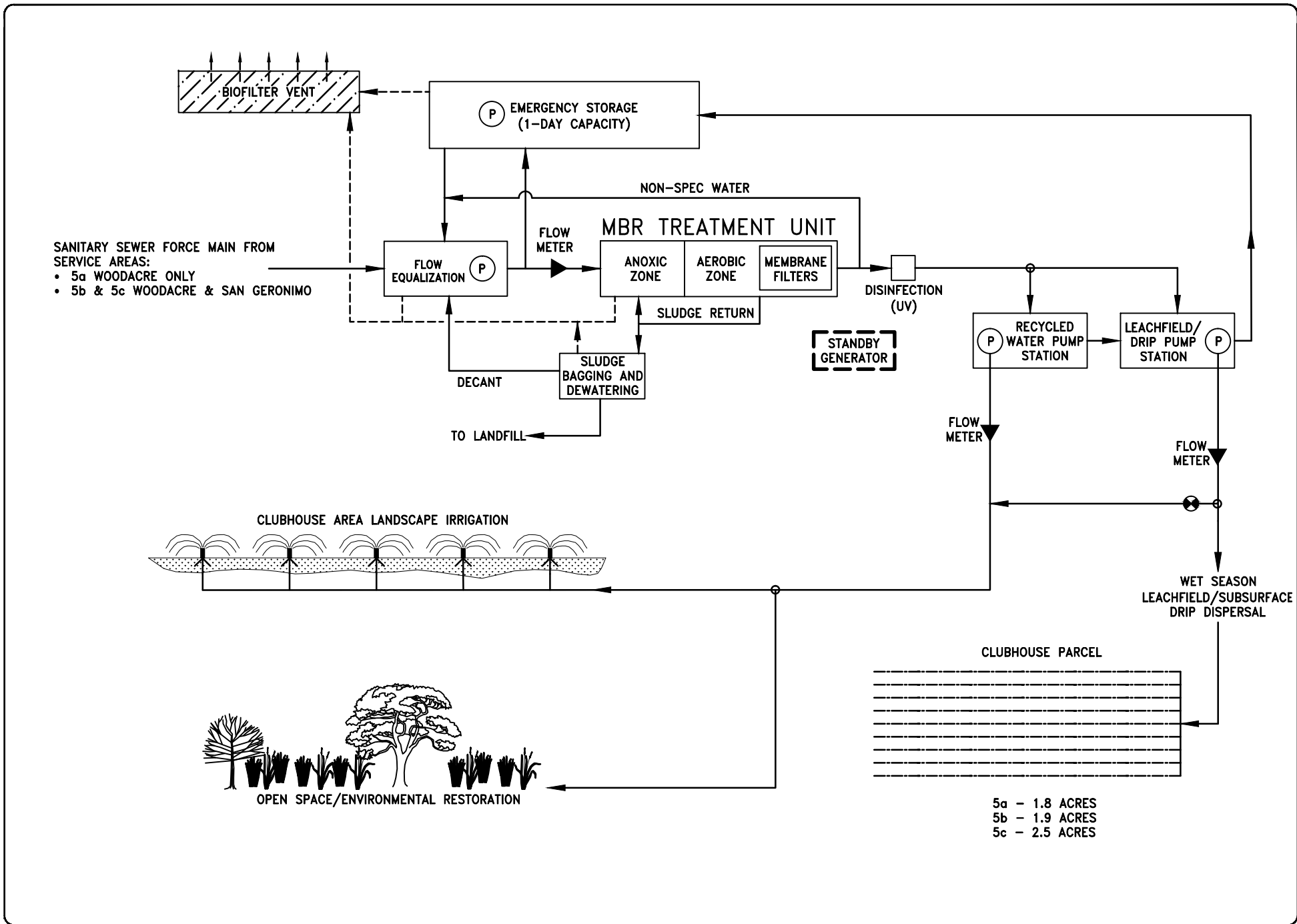

5a - 1.8 ACRES  
 5b - 1.9 ACRES  
 5c - 2.5 ACRES

Site	Rev.	Date	By:	Description:	Appr:

Design:	NH
Drawn:	MF
Checked:	NH
Appr:	NH

P:\3000\0011\WOODACRE\_SANITARY\_FLATS\CD\WDRIF\_FINAL\PROT\_5A\_SCHMATIC\_2-17-14.dwg  
 AUT: 2/27/2019 2:28:49 PM



- 4) During the wet weather season, in lieu of storage ponds, the treated water will be dispersed by means of sub-surface drip fields located in portions of the Clubhouse Parcel.
- 5) This alternative has been developed with capacity to serve all identified parcels in the Woodacre Flats service area, up to 250 parcels.

The wastewater would be treated to meet California Title 22 requirements for disinfected tertiary recycled water, and would reduce the amount of raw water supplied to the property from MMWD for irrigation uses. The treated water would be of a quality suitable for other recycled water uses that might come about through the future conversion and redevelopment of the property, some of which may be year-round uses. These may include:

- Supplemental water to support special habitat restoration, such as wet meadows, requiring season soil saturation;
- Irrigation of open space, redwoods or other vegetation in portions of the golf course dependent on supplemental water historically provided by golf course irrigation;
- Temporary irrigation for establishment of any new plantings on the property;
- Supply of irrigation water to Lagunitas School for playgrounds and landscaping, using existing golf course piping network for transmission;
- Construction water for dust control, soil compaction, equipment cleaning
- Sale of water for sewer cleaning (e.g., Ross Valley Sanitary District) for off-haul by tanker-trucks;
- Fire fighting and fire equipment washing;
- Toilet flushing for new public restrooms if included in future site re-development plans;
- Nursery/greenhouse irrigation if included in future site re-development plans.

Key elements of this alternative are summarized below.

### ***Collection System***

The recommended sewage collection method for this alternative is the same as that for **Alternative 4a** - a conventional gravity system, with a main lift station located at the northeast corner of Railroad Avenue and San Geronimo Valley Drive. Because of the undulating terrain, a pressure sewer would be used for properties along Redwood Drive, tying in at the main lift station. From the lift station, the sewage would be conveyed in a 4-inch diameter force main to the treatment plant location, at one of three potential sites on the golf course Clubhouse Parcel. There are two possible routes for the force main, as follows:

- **Force Main Route A.** This route would follow San Geronimo Valley Drive and Nicasio Valley Road. The force main would be installed within the road right-of-road, either beneath or immediately adjacent to the paved roadway. The force main would enter the golf course Clubhouse Parcel from Nicasio Valley Road, on the west side of the Clubhouse. The force main would cross San Geronimo Creek on the existing road bridge where a ductile iron pipe sleeve would be provided for physical protection of the pipe and prevention/capture of any leakage. The total force main length for Route A is approximately 7,060 feet.
- **Force Main Route B:** This route would run north from the main lift station within the road rights-of way of Railroad Avenue, and then westerly along Sir Francis Drake

Boulevard to the entrance to the San Geronimo Golf Course Clubhouse parcel. At this point the pipeline would follow the entrance driveway to one of three candidate treatment plant sites near the Clubhouse. The pipeline would be buried over its entire length, including where Railroad Avenue crosses San Geronimo Creek; here the pipeline would be installed beneath the road bed, above the concrete box culvert which contains the creek flow at this location. The total force main length for Route B is approximately 5,650 feet.

Analysis indicates force main Route B would be preferred over Route A on the basis of cost (shorter distance) and reduced potential for impacts to San Geronimo Creek. Route B would put the pipeline a much greater distance from San Geronimo Creek along most of its length and would include a less vulnerable means for crossing of the creek – i.e., buried within the road bed of Railroad Avenue rather than sleeved and secured to the road bridge. For either pipeline route, the installation could be done using trenchless technology (horizontal directional drilling) to minimize traffic disruption and physical disturbance to road pavement.

### ***Wastewater Treatment***

As with **Alternative 4**, the treatment facilities under this **Alternative 5 (a, b and c)** would be designed and operated to produce disinfected tertiary water meeting the requirements of California Code of Regulations, Title 22 Water Recycling Criteria (see **Section 5**). Recycled water meeting these standards is acceptable for unrestricted landscape irrigation, golf course irrigation, and several other water recycling uses. (Note: the following discussion and diagrams regarding the wastewater treatment facility are also applicable to **Alternatives 5b** and **5c**, except as to the overall treatment system design capacity and sizing of unit processes.)

- **Treatment Plant Site.** **Figure 6-13** shows the location of three potential sites within the Clubhouse Parcel identified for placement of the wastewater treatment/recycling plant. These are: (a) Site A, in the unpaved space adjacent to the area used for community gardens; (b) Site B, in the upper, paved parking area immediately east of the Clubhouse facility; and (c) Site C on the gently sloping hillside area immediately northwest of the Clubhouse facility. Each candidate site has sufficient land area to accommodate the treatment plant. The sites are outside of the Stream Conservation Area for San Geronimo Creek but do not provide much natural screening from public roads. Additional screening with vegetation and/or structural elements would be needed. The identified treatment plant sites have good vehicular access either from Sir Francis Drake Boulevard or Nicasio Valley Road. A detailed siting analysis and comparison of pros and cons between the alternate locations has not been conducted, but should be done in connection with overall development planning for future uses of the Clubhouse Parcel.

The treatment plant would occupy an area of approximately 10,000 square feet, including above and below ground tanks, blowers, pumps, piping, covered sludge dewatering and bagging area, biofilter venting and appurtenances. There would be a control building (approximately 600 ft<sup>2</sup>) to house electrical/mechanical controls, UV disinfection equipment, a small office, laboratory area, and storage space for equipment and supplies. Allowance has also been included in project cost estimates for an aesthetically suitable structure covering the main elements of the treatment facility, approximately 2,000 ft<sup>2</sup>. The treatment plant area would have parking and vehicle access and would be fenced.

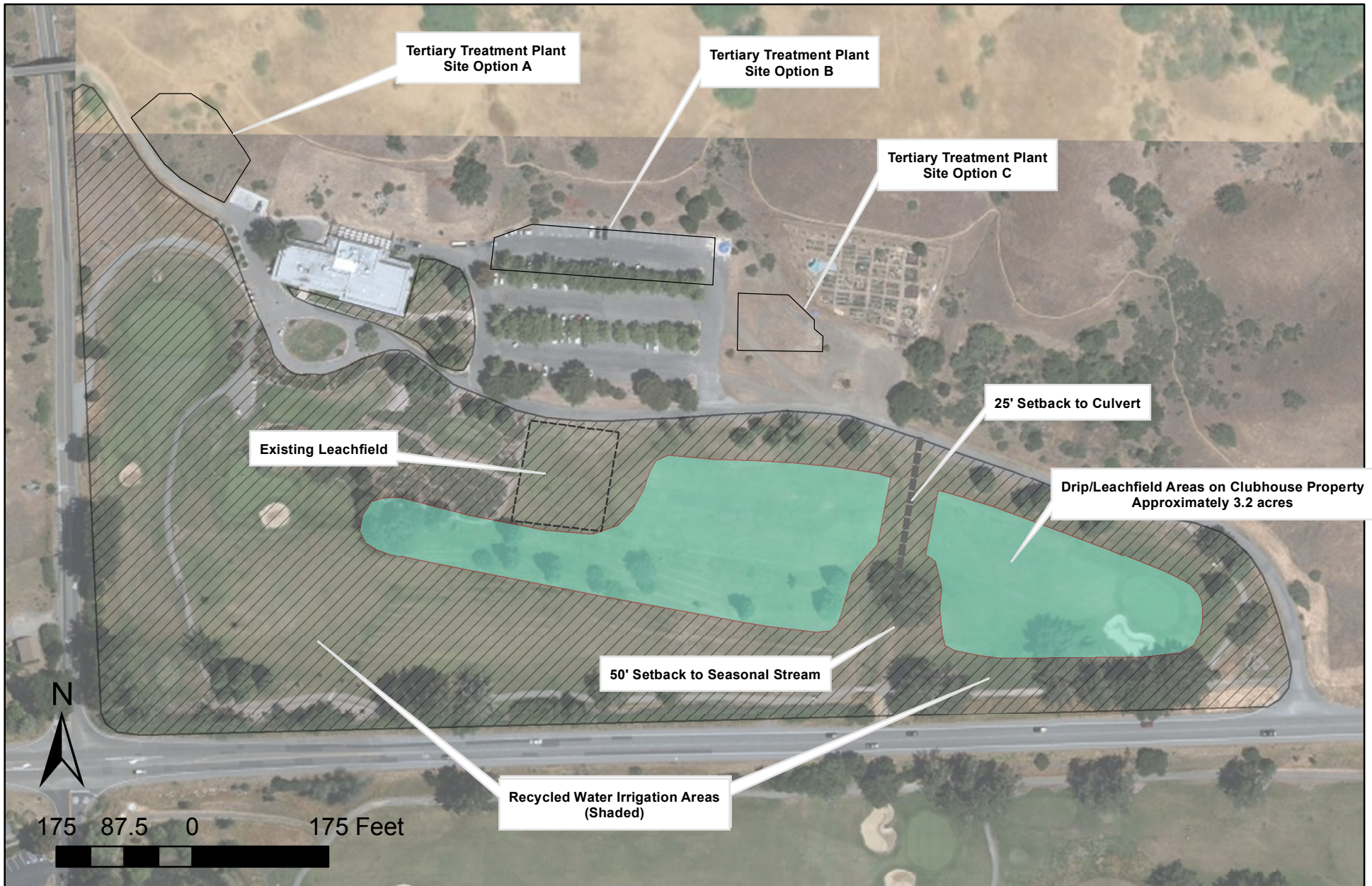

DATE: 2/14/2019  
 PROJECT: WOODACRE WW  
 PROJECT NO: 1600073  
 DRAWN: MF  
 APPROVED: NH



**WASTEWATER FACILITIES  
 ON CLUBHOUSE PARCEL**

**FIGURE 6-13**

- **Title 22 Treatment System – Membrane Bioreactor.** Various types of treatment technologies, designs and manufacturers are available that can meet Title 22 water recycling requirements. The recommended system for this project is a membrane bioreactor (MBR), which is well suited because of the small area requirement, relatively low demands for operator control of the system (based on ease of automation), commercial availability, and acceptance of the technology by the State Water Board's Division of Drinking Water. Background information and technical details on the MBR treatment process (including advantages and disadvantages) are covered in an EPA Fact Sheet, which is provided in **Appendix E** along with example manufacturer information.

The facilities required for an MBR system to meet Title 22 water recycling criteria are diagrammed schematically in **Figure 6-12**. The MBR has small space requirements because it is designed to utilize a single complete mix reactor in which all the steps of the conventional activated sludge process occur with a membrane filter system submerged in the reactor.

Influent sewage enters the treatment plant in a flow-equalization (EQ) tank, which evens out the rate of sewage flow into the main treatment processes. From the EQ tank the raw sewage is pumped into the MBR treatment unit, consisting of an above-ground tank which includes an anoxic zone and aerated zone, pumps, electrically-actuated valves, blowers, level controls, a programmable logic controller (PLC) and ultra-filtration membrane filter. The sewage is mixed with recirculated mixed liquor in the anoxic cell and then flows to the aeration cell. In the aeration cell, the wastewater is aerated through a grid of fine bubble diffusers connected to positive displacement blowers. The ultra-filtration membranes are immersed directly in the aerated mixed liquor and are connected to the suction side of a centrifugal pump (or pumps). The clean permeate is drawn through the membranes and discharged to the disinfection system.

**UV Disinfection.** UV light disinfection is proposed and would be housed in the control building. The system would include dual units, capable of treating the entire flow with one unit out of operation. The selected equipment would be from among several types of UV systems listed and accepted by the DDW including performance validation report. Examples of approved UV systems are provided in **Appendix E**. Field testing of the UV system would be required at the time of installation to validate conformance with Title 22 disinfection/virus inactivation requirements.

**Sludge Handling.** Sludge would be withdrawn periodically from the MBR anoxic tank and collected in an adjacent, covered sludge bagging and dewatering area. Decant from the sludge dewatering tank would be collected and drained back to the EQ tank. The bagged sludge would be hauled for disposal at an approved sanitary landfill. Sludge bags, when filled, would be retained onsite in a covered area for several weeks of drying. Hauling of dry sludge (50-60 lb bags) would occur every few months.

**Odor Control.** Odor control facilities would be included, which are needed primarily in connection with the EQ tank, anoxic tank and sludge bagging/dewatering area. Odors would be controlled through capture and filtering through an organic media bed (biofilter) designed to remove volatile organic compounds, primarily hydrogen sulfide and methane. Activated carbon filters may be used at selected equipment locations, where practicable and if necessary.

**Other Facilities.** Other facilities necessary to satisfy Title 22 recycled water standards include: (a) standby emergency generator to operate the treatment plant during power outages; and (b) emergency storage sufficient to store at least one-day of incoming sewage flow from the service area. This would be provided by one or more large-capacity holding tanks (buried). Additionally, the treatment system would be equipped with automatic turbidity monitoring and control equipment that would temporarily interrupt and redirect the flow of treated water to the influent EQ tank in the event that effluent limits are exceeded or there is a malfunction of the UV disinfection system.

## ***Recycled Water Irrigation and Drip Dispersal Facilities***

### **Recycled Water Distribution Pump Station**

All treated water from the treatment plant will be collected and temporarily stored in an adjacent pump station for distribution for either: (a) landscape/open space irrigation during the dry season; or (b) sub-surface drip dispersal during the wet season. Temporary storage will be provided in below ground tanks with capacity for a minimum of one day of peak wastewater flow. Separate pump systems will be provided for the irrigation system and drip dispersal system. The irrigation pump system will be designed with pressure tanks to provide a consistent pressurized supply to the Clubhouse Parcel for various irrigation uses. The submersible high head pumps will be used for the sub-surface drip dispersal system, sized according the drip field area and design, and provided with timer controls, high-flow override, alarm and remote operating and monitoring provisions.

### **Recycled Water Irrigation**

During the dry season (typically April-October), the water from the recycling facility would be supplied for landscaping, turf and open space irrigation on the Clubhouse Parcel and potentially other parts of the golf course property, which has historically relied on raw water supplies from MMWD. The recycled water would be supplied in a dedicated pressurized recycled water transmission line available for tie-in to the irrigation system(s) at the Clubhouse Parcel. The recycled water would not be connected to or mix with the potable supply to the property. Raw water from MMWD could be mixed with the recycled water to augment the irrigation system supply.

The volume of recycled water produced under **Alternative 5a** under average conditions is estimated to be: (1) approximately 18 acre-feet per year (5.9 million gallons) during the normal irrigation season of April through October; and (2) a total annual volume of 32.4 acre-feet (10.6 million gallons) for irrigation and other potential uses throughout the year. During the normal summer irrigation season the water balance-irrigation calculations indicate the optimum amount of landscape/turf irrigation area to be approximately 6.5 acres; supporting calculations are provided in **Appendix F**.

The golf course property owner/operator would have to comply with recycled water use area requirements, per Title 22 requirements outlined in **Section 5**. These cover items such as signage and markings, protection of drinking water fountains and outdoor eating areas, setbacks from wells, prevention of runoff and spray drift, and protection against cross-connection with domestic water lines.

In addition to irrigation, the treated water could potentially be used for other approved recycled water uses on the Clubhouse Parcel, which would depend on the future development of the property. Recycled water could also be made available through-out the year for off-site use by sewer cleaning services, such as those conducting this work for nearby municipal sewer systems. A pump-out station would be provided for the potential recycled water use. Water for construction uses (e.g., dust control, soil compaction, equipment washing) could also be supplied from the recycled water pump-distribution station, similar to that supplied for sewer cleaning. Either of these uses off-site recycled water uses would require additional user agreements consistent with State requirements.

### **Sub-surface Drip Dispersal Fields**

During the wet season or any other time irrigation uses are suspended, the recycled water would be routed to sub-surface drip dispersal fields. The proposed areas found suitable for sub-surface drip dispersal or treated water are portions of the Clubhouse Parcel as indicated in Figure 6-13. Approximately 3.2 acres of suitable soils have been identified in the general area of golf hole #1 and the rough are between #1 and #9 fairways. This area coincides with soils of suitable depth and permeability as indicated in the Soil Survey of Marin County, and further documented in engineering plans prepared in 2005 for proposed replacement of the golf course clubhouse onsite wastewater system. Approximately 1.8 acres of drip dispersal area would be required for **Alternative 5a**. This is based on an assumed wastewater application rate of 0.4 gallons per day per square feet consistent with the predominant soil conditions.

Additional soils testing of the Clubhouse property would be required to formalize the recommended sizing, configuration and design parameters for a suitable drip dispersal system consistent with Marin County and State requirements. It is also anticipated that the drip field design would be adjusted, as needed, to accommodate future development plans for the Clubhouse Parcel.

### ***Operation and Maintenance Requirements***

The wastewater facilities described under this alternative would require maintenance by a California certified wastewater treatment plant operator (minimum Grade III). This would cover operation, maintenance, and monitoring responsibilities for the collection system, treatment plant, irrigation pumps, storage and pressure tanks, and drip dispersal fields. Clubhouse Parcel property owners/personnel, considered the recycled water "User", would be responsible for maintenance and operation of the irrigation distribution system and the recycled water uses areas (i.e., landscaping, open space and habitat restoration areas, as applicable).

System maintenance would include regular inspection of all equipment and processes. A telemetry system would be incorporated to facilitate remote, continuous monitoring of the critical elements of the pump stations and the treatment system. Ongoing inspection and maintenance of the wastewater treatment facility, collection system, and drip dispersal fields is anticipated to include on-site physical work several days a week.

Effluent water quality sampling and analysis would be an important aspect of the ongoing operation and maintenance of the MBR system and would be required for permit compliance under terms of the Monitoring and Reporting Program established by the Regional Water Board. This would include daily sampling and analysis for coliform bacteria per Title 22 water recycling requirements. Contract arrangements with MMWD for coliform testing at their San Geronimo Water Treatment Plant would be an efficient way to meet this critical operating requirement.

Sampling and analysis of recycled water for “Priority Pollutants”<sup>3</sup> would be required once every five years.

Since the treated water would be incorporated into the golf course property irrigation system for dry season application to landscaping, managed turf and open space areas, monitoring would primarily consist of visual observations of use areas, noting and correcting any evidence of ponding or runoff of irrigation water, and other abnormal conditions. Water quality sampling of the few streams that traverse the portions of the golf course property near the areas of recycled water irrigation may be required. Groundwater level monitoring and potentially some groundwater quality monitoring may be required in the vicinity of the sub-surface drip dispersal fields.

All flow monitoring, influent and effluent water quality data, sludge hauling volumes, and wastewater treatment and water recycled water irrigation/drip dispersal system inspection reports would be prepared and submitted to the San Francisco Bay Regional Water Board according to a schedule prescribed by the Monitoring and Reporting Program. Monthly and annual reporting frequency is anticipated. Annual monitoring data pertaining to the water recycling operations would also be submitted to the DDW.

## ***Estimated Costs***

### **Capital Costs**

The estimated capital costs for **Alternative 5a** are presented in **Table 6-15**, showing the costs for the two alternate force main routes, A and B. The bottom line in the table converts the total project costs to the average cost per connection, based on 250 parcels that would be served. Detailed itemization of costs is provided in **Appendix H**, including quantities and unit cost assumptions. These assumptions were developed through discussions with manufacturers, equipment suppliers, and local contractors, and through review of recent contractor bids for similar work in Marin County, where applicable. Included are all expected costs for new gravity and pressure sewers, lift station and transmission line to the golf course property, MBR treatment system, recycled water irrigation/dispersal pumps, storage and pressure tanks, irrigation transmission line to Clubhouse Parcel system, and drip dispersal field piping, valves and appurtenances in Clubhouse Parcel. Also included is a 10% contingency allowance, as well as estimated costs for engineering design, environmental studies, construction management, project administration, district formation and financing. The cost difference between force main route A and B is about \$650 per parcel, in favor of Route B. The estimated total project cost (force main Route B) is approximately \$9.8 million with an approximate cost of \$39,170 per parcel served (assuming 250 connections plus the golf course clubhouse).

### **Operation and Maintenance Costs**

The estimated annual operation and maintenance costs for **Alternative 5a** are provided in **Table 6-16**, with supporting itemized calculations and assumptions provided in **Appendix H**. The O&M cost are estimated based on labor, equipment, materials and other expenses required to perform the necessary inspections, water quality sampling, data analysis, report preparation, sludge disposal, and routine maintenance for the collection system MBR treatment/recycling plant, recycled water pump station, storage tanks and transmission lines, and sub-surface drip

---

<sup>3</sup> Priority Pollutants refer to a list of 126 specific pollutants that includes heavy metals and specific organic chemicals.

dispersal fields adjacent to Sir Francis Drake Boulevard and on the Clubhouse Parcel. Also included are estimates of annual energy costs (electrical) for operation of the Woodacre main lift station, treatment system, recycled water pump station, storage and pressure tanks, transmission lines, and sub-surface drip dispersal fields along Sir Francis Drake Boulevard and on the Clubhouse Parcel. Not included are costs associated with the operation and maintenance of the landscape irrigation piping, sprinklers, controllers and vegetation on the Clubhouse Parcel. O&M costs include an allowance for equipment repair/replacement, which would be required over the life of the system. An allowance of 10% is included as a contingency. The cost estimates were developed based on the expected operation and monitoring needs defined above, and using data and experience from monitoring and maintenance of other similar systems in Marin County and other Northern California communities. The total annual O&M cost is estimated to be about \$348,800, with a per parcel annual cost of \$1,368.

**Table 6-15. Estimated Capital Costs – Alternative 5a**

<b>Cost Item</b>	<b>Route A - Cost (\$)</b>	<b>Route B - Cost (\$)</b>
Collection System (Gravity Sewer)*	\$4,326,175	\$4,216,575
Tertiary Treatment Plant	\$1,433,000	\$1,433,000
Recycled Water Storage & Transmission	\$750,500	\$750,500
Land/Easement Costs	0	0
Mobilization/Demobilization	100,000	100,000
Permit Fees & Encroachment Fees	50,000	50,000
<b>Subtotal</b>	<b>\$6,659,675</b>	<b>\$6,550,075</b>
Contingency @ 15%	\$998,951	\$982,511
<b>Subtotal</b>	<b>\$7,658,626</b>	<b>\$7,532,586</b>
Engr & Environ Studies @ 15%	\$1,148,794	\$1,129,888
Construction Management @ 10%	\$765,863	\$753,259
Admin, Dist Formation, Financing @ 5%	\$382,931	\$376,629
<b>Total Estimated Cost</b>	<b>\$9,956,214</b>	<b>\$9,792,362</b>
<b>Estimated Cost Per Connection</b>	<b>\$39,825</b>	<b>\$39,169</b>

\* Does not include individual property owner cost for septic tank abandonment and on-lot work to connect house plumbing to new sewer system, typical range of \$1,500 to \$3,000.



**Table 6-16. Estimated Annual O&M Costs – Alternative 5a**

Category	Items	Cost (\$)
<b>District/Program Administration</b>	Insurance, legal, financial, administration	15,000
	RWQCB Permits	10,000
<b>Labor – Collection &amp; Treatment</b>	Systems Control Technician	12,000
	Grade III Operator	46,800
	Grade I Operator	39,000
	Field Technician	62,400
	Engineering Consultation	12,000
	On-call Monitoring & Response Allowance	12,000
<b>Sludge Handling</b>	Bagging, Materials and Disposal Fees	3,600
<b>Sewer Lines</b>	Maintenance Cleaning	4,000
<b>Equipment</b>	Materials & Replacement	42,000
<b>Vehicle</b>	Lease and mileage	4,800
<b>Laboratory and Expenses</b>	Laboratory	24,000
	Cleaning Chemicals & Supplies	3,000
<b>Electrical</b>	Lift Station	660
	MBR Treatment Plant	19,454
	UV Disinfection	2,569
	Treated Water Distribution	3,212
	Misc electrical, phone, internet	600
<b>Sub-total</b>		<b>\$ 317,095</b>
10% Contingency		\$ 31,710
<b>Estimated Total Annual Cost</b>		<b>\$ 348,805</b>
<b>Estimated Annual Cost per Connection (365 ESDs<sup>1</sup>)</b>		<b>\$ 1,368</b>

<sup>1</sup> Includes additional allowance of 5 ESDs for service to golf course clubhouse

## **Alternative 5b – Woodacre/San Geronimo – Partial Service, 270 Parcels**

**Alternatives 5b** and **5c** would expand the water recycling system described in **Alternative 5a** (Woodacre Only) to include service to both Woodacre and San Geronimo. Two variations, **Alternatives 5b** (partial) and **5c** (full), were formulated and evaluated to consider different levels of service (number of parcels) in the two communities. **Figure 6-11** shows the location of key features of **Alternatives 5b** and **5c**. **Figure 6-12** provides an overall schematic of the wastewater treatment and recycling system.

This alternative would be an expansion of **Alternative 5a**, including wastewater service to approximately 75% of the developed properties in both Woodacre and San Geronimo. It would include wastewater collection facilities throughout both communities, with the assumption that approximately 270 of the property owners would opt to connect to the system. Those not connecting would continue to be served by their existing/improved onsite septic systems.

**Alternative 5b** would include all wastewater facilities described in **Alternative 5a**, with the following changes and additions:

- **Collection System.** The wastewater collection system in San Geronimo would consist of (a) pressure sewers with individual grinder pumps at each property; and (b) pressure sewer force mains installed in Sir Francis Drake Boulevard, San Geronimo Valley Drive and Meadow Way, connecting at the western driveway entrance into the golf course maintenance area.
- **Treatment System.** The tertiary treatment plant would be expanded to provide a capacity of 35,000 gpd (45,000 gpd peak flow), including upsizing tanks, pumps and other equipment as needed. Estimated average daily wastewater flow (wet season) for this alternative is 33,200 gpd.
- **Irrigation/Drip Dispersal Pump Station.** The irrigation/drip dispersal pump station would be enlarged to 40,000 gallons to provide increased short-term storage capacity for flow regulation.
- **Landscape Irrigation Area.** The dedicated area(s) on the Clubhouse Parcel for landscape irrigation with recycled water would be increased to 7 acres.

**Drip Dispersal Area.** The area and facilities for winter season drip dispersal of treated water within the Clubhouse Parcel would be increased to approximately 1.9 acres.

## Alternative 5c – Woodacre/San Geronimo - Full Service, 360 Parcels

This alternative is an expanded version of **Alternative 5b**, with facilities sized to provide service to essentially all 360 developed properties in the Woodacre and San Geronimo communities. The expanded capacity would be achieved by the following:

- **Treatment Plant Capacity.** The tertiary treatment plant would be expanded to provide a capacity of 50,000 gpd (60,000 gpd peak flow), including upsizing tanks, pumps and other equipment as needed. Estimated average daily wastewater flow (wet season) for this alternative is 44,000 gpd.
- **Irrigation/Drip Dispersal Pump Station.** The irrigation/drip dispersal pump station would be enlarged to 60,000 gallons to provide increased short-term storage capacity for flow regulation.
- **Landscape Irrigation Area.** The dedicated area(s) on the Clubhouse Parcel for landscape irrigation with recycled water would be increased to 9 acres.

**Drip Dispersal Area.** The area and facilities for winter season drip dispersal of treated water within the Clubhouse Parcel would be increased to approximately 2.5 acres.

The estimated volume of recycled water produced for **Alternatives 5a** and **5b** for average flow conditions are summarized in **Table 6-17**. Shown in the table are: (1) recycle water produced for irrigation (or other purposes) during the normal irrigation season of April through October; and (2) total annual volume of recycled water produced and available for irrigation and other potential uses throughout the year. During the normal summer irrigation season the water balance-irrigation calculations indicate the optimum amount of landscape/turf irrigation area to be approximately 7 acres for **Alternative 5a** and 9 Acres for **Alternative 5b**; supporting calculations are provided in **Appendix F**.

**Table 6-17. Recycled Water Produced – Average Annual Volumes**

Alternative	Recycled Water Produced Irrigation Season (Apr-Oct)		Recycled Water Produced Annual Total	
	Acre-feet	Million gals	Acre-feet	Million gals
<b>Alternative 5b</b>	19.4	6.32	34.8	11.34
<b>Alternative 5c</b>	25.6	8.34	46.0	15.0

***Estimated Costs***

**Capital Costs**

The estimated capital costs for **Alternatives 5b** and **5c** are presented in **Table 6-18**, including wastewater collection, tertiary treatment plant, water recycling storage, irrigation/dispersal pumps, transmission lines, and drip dispersal facilities, along with a contingency factor and estimated implementation costs. As indicated, the total estimated project costs are \$11.7 million **Alternative 5b** and \$13.5 million for **Alternative 5c**. The bottom line in the table converts the total project costs to the average cost per connection, showing costs of about \$43,300 for **Alternative 5b** and \$37,500 for **Alternative 5c**. Detailed itemization of costs is provided in **Appendix H**, including quantities and unit cost assumptions.

**Table 6-18. Estimated Capital Costs - Alternatives 5b & 5c**

Cost Item	Alternative 5b 270 Parcels	Alternative 5c 360 Parcels
Collection System – Woodacre (Route B)*	\$3,913,775	\$4,216,575
Collection System – San Geronimo*	\$1,486,800	\$1,956,800
Tertiary Treatment Plant	\$1,473,000	\$1,688,000
Recycled Water Irrigation and Drip Dispersal	\$800,000	\$1,022,500
Land/Easement Costs	-	-
Mobilization/Demobilization	100,000	100,000
Permit Fees & Encroachment Fees	50,000	50,000
<b>Subtotal</b>	<b>\$7,823,575</b>	<b>\$9,033,875</b>
Contingency @ 15%	\$1,173,536	\$1,355,081
<b>Subtotal</b>	<b>\$8,997,111</b>	<b>\$10,388,956</b>
Engineering & Environmental Studies @ 15%	\$1,349,567	\$1,558,343
Construction Management @ 10%	\$899,711	\$1,038,896
Project Admin, Dist Formation, Financing @ 5%	\$449,856	\$519,448
<b>Total Estimated Cost</b>	<b>\$11,696,245</b>	<b>\$13,505,643</b>
<b>Estimated Cost Per Connection</b>	<b>\$43,319</b>	<b>\$37,516</b>

\* Does not include individual property owner cost for septic tank abandonment and on-lot work to connect house plumbing to new sewer system, typical range of \$1,500 to \$3,000.

**Operation and Maintenance Costs**

Estimated annual operation and maintenance costs for **Alternatives 5b** and **5c** are provided in **Table 6-19**, with supporting itemized calculations and assumptions provided in **Appendix H**. The O&M cost are estimated based on labor, equipment, materials and other expenses required

to perform the necessary inspections, water quality sampling, data analysis, report preparation, sludge disposal, and routine maintenance for the collection system, MBR treatment/recycling plant, recycled water pump station, storage and pressure tanks, transmission lines, and sub-surface drip dispersal fields on the Clubhouse Parcel. Not included are costs associated with the operation and maintenance of the landscape irrigation piping, sprinklers, controllers and vegetation on the Clubhouse Parcel. Also included are estimates of annual energy costs (electrical) for operation of the Woodacre main lift station, treatment system, and irrigation and drip dispersal pump stations. O&M costs include an allowance for equipment repair/replacement, which would be required over the life of the system. An allowance of 10% is included as a contingency. As indicated, the total estimated annual O&M costs are about \$365,900 for **Alternative 5b** and \$417,500 for **Alternative 5c**. The resulting annual cost per parcel would be approximately \$1,330 for **Alternative 5b** and \$1,144 for **Alternative 5c**.

**Table 6-19. Estimated Annual O&M Cost – Alternatives 5b & 5c**

Category	Items	Alternative 5b Cost (\$)	Alternative 5c Cost (\$)
<b>District/Program Administration</b>	Insurance, legal, financial, administration	15,000	18,000
	RWQCB Permit	10,000	10,000
<b>Labor Collection &amp; Treatment</b>	Systems Control Technician	12,000	14,000
	Grade III Operator	46,800	46,800
	Grade I Operator	39,000	57,000
	Field Technician	62,400	62,400
	Engineering Consultation	12,000	15,000
	On-call Monitoring & Response Allowance	12,000	12,000
<b>Sludge Handling</b>	Bagging, Materials and Disposal Fees	3,600	4,800
<b>Sewer Lines</b>	Maintenance Cleaning	6,000	6,000
<b>Equipment</b>	Materials & Replacement	54,000	66,000
<b>Vehicle</b>	Lease and mileage	4,800	4,800
<b>Laboratory and Expenses</b>	Laboratory	24,000	24,000
	Cleaning Chemicals & Supplies	3,000	3,600
<b>Electrical</b>	Lift Station	660	660
	MBR Treatment Plant	20,776	27,530
	UV Disinfection	2,753	3,212
	Treated Water Distribution	3,212	3,212
	Misc electrical, phone, internet	\$600	600
<b>Sub-total</b>		<b>\$ 332,600</b>	<b>\$379,613</b>
10% Contingency		\$33,260	\$37,961
Estimated Total Annual Cost		<b>\$ 365,860</b>	<b>\$417,575</b>
<b>Estimated Annual Cost per Connection<sup>1</sup></b>		<b>\$ 1,330</b>	<b>\$1,144</b>

<sup>1</sup> Includes additional allowance of 5 ESDs for service to golf course clubhouse

## SECTION 7: COMPARATIVE ANALYSIS OF PROJECT ALTERNATIVES

This section reviews the advantages and disadvantages of the various project alternatives with respect to regulatory compliance, environmental impacts, reliability, energy use, water conservation/water recycling, land use, and costs. A comparative summary and ranking is provided at the end of the section, along with identification of the “apparent best” alternative(s).

### REGULATORY COMPLIANCE

The primary goal of a wastewater facilities project in the Woodacre-San Geronimo study area is to correct existing water quality, public health and nuisance problems, and bring wastewater disposal activities into compliance with accepted sanitary practices and environmental quality standards. For project alternatives providing water recycling benefits, compliance with requirements of California Code of Regulations, Title 22 Water Recycling Criteria is applicable.

**Alternative 1** (No Project) fails to achieve water quality and public health objectives although, as property owners gradually repair or replace existing systems, improvements in local water quality, public health, and sanitation conditions would occur to some degree over a number of years. It is estimated that nearly 70% of the properties in the Woodacre-San Geronimo area are in serious conflict with current septic system standards and would have significant difficulty complying with County repair standards, particularly if requirements applicable to downstream impaired water bodies (Lagunitas Creek and Tomales Bay) are applied throughout the study area.

**Alternative 2** would substantially reduce present water quality and public health problems, and bring more (as compared with the No Project option) of the existing onsite systems into conformance with accepted practices. Where this alternative falls short of meeting environmental health/water quality requirements would be in the heavy reliance on advanced treatment systems and repair-based variances for many of the properties in the service area, along with the need for continued monitoring and surveillance to document suitable system performance and compliance with water quality objectives. The need for advanced treatment systems results from the shallow soil and groundwater conditions combined with the land area/setback constraints due to the small lot sizes and intensity of development.

**Alternative 3** would be expected to satisfy State and Regional Water Board septic system repair requirements for the limited portion of the study area served, approximately 50% of the total number of properties (176 out of 360). The system would include supplemental (secondary) wastewater treatment, nitrogen removal and a dual, 200% capacity, pressure distribution leachfield system. This would be consistent with applicable standards for small domestic wastewater treatment systems contained in State Water Board Order No. 20140-0153-DWQ, including requirements related to the impaired water body status of Lagunitas Creek and Tomales Bay. However, the approximately 50% of the study area properties not able to be served by the community wastewater system would either remain in the status quo (**Alternative 1**), or potentially could be addressed through implementation of an onsite system upgrade and management program per **Alternative 2**. For the overall study area, **Alternative 3** would achieve a mix of full and partial regulatory compliance per the features of **Alternatives 1, 2 and 3**.

Water recycling **Alternatives 4 and 5** would comply with California Water Recycling Criteria for disinfected tertiary recycled water, representing a higher environmental standard than that

applicable to the non-recycling alternatives regarding the level of treatment and the final use and dispersal of the treated water. The water recycling alternatives differ in their capacity to serve the properties in the study area, ranging from about 60% of properties under **Alternative 4a** up to 100% under **Alternatives 4c** and **5c**. Properties not able to be served would be subject to prevailing onsite septic system requirements and potentially corrective measures related to impaired water body status of Lagunitas Creek and/or Tomales Bay.

## ENVIRONMENTAL IMPACTS

A complete environmental impact report will be prepared separately as part of the overall facilities planning work. Provided here is a brief overview of the environmental issues posed by the different alternatives, other than water quality/sanitation covered above under Regulatory Compliance. This review is intended to assist in assessing project feasibility and identification of the preferred alternative; it is not a substitute for the environmental documentation requirements of the California Environmental Quality Act.

**Alternative 1** would include an unknown number of new and upgraded onsite wastewater systems using conventional septic tanks and disposal systems similar to existing practices. There would be increased use of pump systems, soil fill, and drainage work, amounting to increases in the amount of land disturbance compared with current and historical practices. The general trend would be toward installing shallow disposal fields matched more closely with the limited depth of suitable soils. A negative impact of the No Project alternative would be the lack of any comprehensive plan or schedule to bring about the upgrading of onsite systems, and the continued potential for existing impacts on public health and water quality to occur. Another negative aspect of this alternative would be the possible need to revert to holding tanks and regular sewage hauling for some properties that have no acceptable on-lot options.

**Alternative 2** would largely eliminate the public health hazards from failing or poorly functioning septic systems through elimination of problematic systems, addition of individual advanced treatment units, and development of upgraded and improved means for onsite dispersal of the treated water. The institution of an onsite wastewater management program would provide the means for monitoring each system to oversee the protection of the local environment against wastewater impacts. A potential negative aspect of this plan would be the land disturbance required on individual properties to upgrade onsite systems. The importing of soil fill, removal of landscaping to make room for advanced treatment units, and raised bed dispersal systems would likely be objectionable in many instances. Conflicts with other uses of limited available land area would be a potentially significant issue. Also, similar to **Alternative 1**, there may be instances requiring holding tanks and regular sewage hauling as part of a solution for some properties.

**Alternative 3** would pose environmental impacts related to the construction of a sewer system, lift stations, treatment facilities, effluent force main and disposal field at the Fire Road site. The collection system, utilizing small diameter piping, would generate impacts during the construction phase. Also, the recommended sewer option includes the continued use of on-lot septic tanks with a combination of small diameter gravity and pressure pumping (STEP) systems. This would result in the continuing need for septic tank and pump maintenance on individual properties, along with routine septic tank cleaning. Pump failures and/or pipeline leaks or breaks would pose the potential for discharge of partially treated sewage to the environment if not properly mitigated through design and operational procedures.

Another impact of the Fire Road alternative would be posed by the conversion of the Park Street area to a site for a secondary wastewater treatment plant and effluent lift station. The treatment plant would mainly consist of below ground or low-profile tanks and submersible pumps, plus a small control building. It would be fenced and could be screened with vegetation to mitigate visual impacts. Noise levels would be low, but there would be regular activity at the site, routine maintenance and running of a standby generator. Sewage odors would be generated, but can be mitigated with appropriate odor control facilities normally part of the treatment system design.

The Fire Road leachfield site and the pipeline route to the site would involve a substantial amount of excavation, tree removal, and vegetation clearing, requiring mitigation for erosion control and reestablishment of native vegetation. The leachfield site and force main route were identified to avoid geologically unstable areas; however, there are steep slopes and potentially unstable lands in the vicinity, which would require evaluation to confirm avoidance of impacts or other mitigation measures. Restoration and revegetation of land areas disturbed by the leachfield and pipeline construction would be relatively straightforward. The dispersal of secondary treated effluent is compatible with the soil conditions in the identified leachfield site. However, additional soils and groundwater investigation and the potential for impacting water quality or hydrology in locations downgradient/downhill from the leachfield site would need to be considered as part of formal environmental review and system design.

Water recycling **Alternatives 4 and 5** would have environmental impacts, including: (a) within the Woodacre and San Geronimo communities related to the construction and operation of wastewater collection systems; (b) 1-mile sewage force main from Woodacre to the golf course property; (c) water recycling facilities at the golf course property; (d) surface irrigation of landscaping and open space on the golf course property with recycled water; and (e) sub-surface drip dispersal of treated water on portions of the golf course property. Between the alternatives, the level of potential impact would increase according to the service area size, treatment system capacity and level of facilities construction required.

- **Collection System.** The collection system would include impacts related to installation of gravity sewers and pressure sewer lines in Woodacre and San Geronimo. This would include disruption of traffic, noise, and potential for soil erosion, dewatering or runoff issues. Pressure sewer installation using horizontal directional drilling methods would be less disruptive than gravity sewer construction, which would be done using open cut trenching methods. Existing septic tanks and disposal fields would be decommissioned/abandoned, and replaced with a gravity connection to the sewer system where feasible. The Redwood Avenue portion of Woodacre and all of San Geronimo, would be served by pressure sewers, which would include an on-lot grinder pump and pressure connection lines to the pressure sewer mains in the street. This would result in the continuing need for pump servicing on these individual properties. Pump failures and/or pipeline leaks or breaks would pose the potential for plumbing backups or discharge of raw sewage to the environment if not properly maintained.
- **Woodacre–Golf Course Property Force Main.** There are two alternate pipeline routes from Woodacre to the golf course property treatment plant site: (a) via San Geronimo Valley Drive (Route A); and (b) via Railroad Avenue and Sir Francis Drake Boulevard (Route B). The two pipeline routes differ in length (Route B is shorter) and estimated costs; both would be within public road right of ways their entire length until entering golf course property. Regardless of the route, it is likely that the pipeline would be installed for most of its length using trenchless methods (i.e., horizontal directional drilling), to minimize excavation, soil erosion hazards and impacts to road surfaces and traffic.

Route A would generally run parallel to San Geronimo Creek for most of its length, eventually crossing the creek at the bridge near Meadow Way. This would be done using ductile iron pipe secured to the downstream side of the bridge deck for support, protection of the pipe and double-containment against pipe leaks. Route B would be buried in the road bed of Railroad Avenue where it crosses San Geronimo Creek; the remainder of the pipeline route would be a much greater distance from San Geronimo Creek than for Route A.

**Recycled Water Facilities.** Potential impacts of the recycled water facilities would include: (a) those associated with the treatment plant (visual, odors, noise, spills) located in one of three possible sites on the Clubhouse Parcel or at the maintenance complex; (b) the construction and maintenance of one or two recycled water storage ponds in currently unused parts of the golf course (**Alternative 4**); or (c) construction and maintenance of buried storage tanks and pumping facilities to collect and distribute recycled water for sub-surface dispersal and surface irrigation of landscaping and open space areas of the golf course property. The treatment plant would be of a compact design, provided with odor control facilities and located and screened to minimize visual, noise and operational impacts locally. For **Alternative 5**, costs are included for the option of providing a building-like shell (approximately 2,000 ft<sup>2</sup>) to screen the main treatment facilities from view. The treatment system would be required to comply with Title 22 standards for water recycling, which are very stringent in the direction of public health and water quality protection. For **Alternative 4**, the storage ponds on the golf course would be designed to capture and hold rainfall as well as tertiary treated water for 100-yr seasonal rainfall occurrence (75.3 inches annual rainfall), plus freeboard allowance. The ponds would have to be managed to control mosquitoes, prevent overflows, and be maintained in a safe condition and fenced to restrict access by golfers or others. For **Alternative 5**, the recycled water storage and pumping facilities would consist of below-ground tanks, pumps, pressure tanks and controls located at or in close proximity to the recycled water treatment plant. Any above-ground facilities (e.g., pressure tanks, controls) would be housed in a small building enclosure for security, equipment protection, visual screening, and muffling of pump operating noise. There would be no offensive odors associated with the storage and dispersal of the tertiary-treated recycled water.

- **Golf Course or Landscape Irrigation with Recycled Water.** During the dry season, dispersal of the recycled water would be integrated into either the existing golf course irrigation system (**Alternative 4**), the landscape irrigation system for the Clubhouse Parcel, and potentially for open space and habitat restoration on other portions of the golf course property (**Alternative 5**). Application of recycled water would typically be during the period of April-October, at irrigation application rates. Application of recycled water could also take place during the winter months, depending on weather conditions, and only to areas where there is no threat of runoff to local drainages or San Geronimo Creek. Violation of the standard conditions of Title 22 and Regional Water Board requirements could result in recycled water runoff into San Geronimo Creek. The recycled water would amount to a relatively small percentage of the total amount of irrigation water historically applied for golf course irrigation. Irrigation would be supplied in a dedicated pressurized system from the recycling facility, and managed through a separate irrigation controller (and manual methods) operated by the golf course property owner/operator; this would allow a high degree of control and flexibility in the timing and conditions for applying recycled water.



Application of recycled water also requires consideration of public health impacts. This is a low environmental/public health threat due the fact that the wastewater will be treated to a tertiary level, deemed by California Title 22 standards to be suitable for surface irrigation in areas where human contact with the treated water can be expected, e.g., at parks, golf courses and similar irrigated public areas. By regulation, signs will be posted and drinking water fountains will be isolated from irrigated areas to alert the public and minimize the chances of contact with recycled water.

- **Sub-surface Drip Dispersal Fields.** Under **Alternative 5**, during the wet season and at other times when landscape irrigation is not possible or needed, the recycled water would be dispersed to a series of sub-surface drip dispersal fields, designed and operated consistent with standard practices used for onsite wastewater systems in Marin County and elsewhere in California. The proposed drip dispersal fields would be within an approximately 3.2-acre area of the Clubhouse Parcel between the main parking lot and Sir Francis Drake Boulevard. This corresponds general to existing golf hole #1 and adjacent “rough” area. Prior soil investigations for the Clubhouse leachfield along with published Soil Survey information indicate suitable soils and for sub-surface drip dispersal fields in this area. The operation, maintenance and monitoring of the drip dispersal fields would be by the recycled water facilities operator.

## RELIABILITY

Reliability considerations relate to the ability to consistently meet wastewater treatment and disposal objectives and have adequate provisions for emergencies, malfunctions, extreme climatic conditions, or fluctuations in flow.

**Alternative 1** rates poorly in terms of reliability. Options to correct existing septic system problems would be limited and costly. Some property owners would have extreme difficulty finding solutions that can assure long-term performance reliability because of shallow soil/groundwater conditions, space limitations, and proximity to waterways. Without a concerted effort to systematically assess and upgrade existing systems, many systems would remain “as is” and a source of continuing public health and water quality concerns.

**Alternative 2** represents a substantial improvement in reliability through the proposed implementation of an onsite system inspection and maintenance program. However, the need to rely on many individual advanced treatment units, although feasible, would intensify the oversight and maintenance requirements, and affect overall reliability of this alternative.

**Alternative 3** (Fire Road Leachfield) offers a high degree of reliability over present sewage disposal practices for the Woodacre properties served. The facilities would be capable of meeting accepted State standards for wastewater treatment and disposal, including built-in emergency and redundancy provisions for potential equipment failures, power outages, etc. The inclusion of secondary wastewater treatment prior to disposal reduces the amount of dependence on the soil environment for absorption and treatment of wastewater constituents, which improves the reliability of this alternative. The provision of a dual, 200% capacity, leachfield system would provide an added redundancy, also helping to preserve and extend the life of the wastewater dispersal field. The electrical and mechanical elements of the secondary treatment system, as well as the individual pump systems within the collection system, would be subject to periodic malfunction. However, these aspects of the treatment system can be routinely monitored, maintained, repaired and replaced as necessary. The types of operating

issues and maintenance for wastewater facilities under **Alternative 3** would be similar to those faced by individual properties utilizing alternative onsite wastewater systems per **Alternative 2**. For the study area as a whole, since **Alternative 3** would only provide facilities to serve about half of the properties, overall reliability would be judged as a mix of reliability offered by **Alternatives 1, 2 and 3**.

Water recycling **Alternatives 4 and 5** would provide a higher level of reliability than the non-water recycling alternatives, as they would have to be designed and operated to comply with State standards (Title 22) for disinfected tertiary recycled water. The applicable standards for water recycling facilities have built-in redundancy and fail-safe requirements to assure against human health impacts from exposure to recycled water. These requirements include such things as automatic monitoring and control systems, duplicate unit processes, and emergency storage/holding capacity. Storage ponds, where used, would be sized for 100-yr seasonal rainfall conditions (plus freeboard). The method of final dispersal of the tertiary treated water (winter storage ponds or sub-surface drip fields/summer surface irrigation) is inherently more reliable than depending on year-round soil absorption, as per the other alternatives. Compared to one another, the reliability of the water recycling alternatives would increase in proportion to the system capacity and number of properties in the study area that could be served.

## Energy Use and Greenhouse Gases

**Alternative 1** would create new energy requirements and resource demands where individual actions are taken to upgrade existing septic systems with more modern treatment devices.

**Alternative 2** would increase energy requirements in comparison with the No Project alternative, since a substantial number of properties would be served by an advanced treatment/dispersal system utilizing pumps and possibly UV disinfection and aeration units. There would also be increased usage of fossil fuels for **Alternative 2** as a result of the construction work for onsite system improvements, regular inspection and monitoring activities, and a somewhat higher rate of septic tank pump-outs that would likely occur with a management program in place.

**Alternative 3** would have increased energy requirements, in comparison with **Alternatives 1 and 2**, because of the need to pump the wastewater to offsite treatment/disposal locations and the operation of pumps and other equipment needed for secondary treatment facilities. There would also be increased usage of fossil fuels as compared with **Alternatives 1 and 2** as a result of the more extensive construction work for the community system improvements, and ongoing inspection and monitoring activities.

Water recycling **Alternatives 4 and 5** would have substantially greater energy requirements than the non-water recycling alternatives due to: (a) the pumping requirements to bring all wastewater to the proposed treatment plant location at the golf course property; (b) treatment facilities needed to produce disinfected tertiary-level recycled water; and (c) pumping requirements to distribute the recycled water to locations on the golf course property for either storage and integration into the golf course irrigation system (**Alternative 4**) or sub-surface drip dispersal and surface irrigation of landscaping and open space areas (**Alternative 5**). The energy requirements would increase in proportion to the treatment capacity and number of parcels served under each recycling alternative. **Table 7-1** summarizes the estimated annual energy use for each alternative, showing the breakdown between the collection system and

treatment and distribution system. For comparison, the typical annual energy use for an advanced individual residential onsite treatment system would be on the order of about 100 to 200 kW-hrs per year per system. The water recycling facilities would also entail substantially greater usage of fossil fuels for construction of the wastewater collection, treatment and dispersal/irrigation facilities as compared with the non-recycled water alternatives. Relative to one another, usage of fossil fuels for project construction among the water recycling alternatives would be in proportion to the system capacity and number of parcels served, similar to operating energy use per **Table 7-1**. Also shown as a point of reference are the projected energy costs associated with the operation of upgraded onsite wastewater treatment systems under **Alternative 2**.

**Table 7-1. Estimated Annual Energy Use for Project Alternatives**

Alternative	Average Wet Weather Flow (gpd)	Parcels Served	Estimated Annual Energy Use (kW-hrs/yr)		
			Collection System	Treatment & Distribution	Total
<b>2</b>	n/a	360	n/a	100 to 200/parcel	36,000 to 72,000
<b>3</b>	26,400	176	7,200	75,800	83,000
<b>4a</b>	26,000	210	5,800	135,000	140,800
<b>4b</b>	33,200	270	9,100	145,700	154,800
<b>4c</b>	44,000	360	12,600	185,000	197,600
<b>5a</b>	30,800	250	6,400	137,500	143,900
<b>5b</b>	33,200	270	10,400	145,700	156,100
<b>5c</b>	44,000	360	15,000	185,000	200,000

Estimated greenhouse gas emissions (GHG), for all project alternatives over a projected 30-yr period are summarized in **Table 7-2**. Supporting assumptions and calculations are provided in **Appendix I**. The estimated GHG are expressed as tons of equivalent CO<sub>2</sub>, including contributions from the construction phase and 30 years of system operation and maintenance. GHG reductions for water recycling are included where applicable, based on the avoided electrical energy required for transmission of the equivalent volume of MMWD raw water supplies replaced by use of recycled water. For Alternatives 3 through 5, parcels not served by the community system are accounted for as “Remaining OWTS”, with GHG emissions based on per parcel estimates per Alternative 2 (i.e., Onsite Wastewater Management Program). Additional detailed review of and evaluation of greenhouse gas emissions will be covered in the subsequent environmental impact study of project alternatives.

**Table 7-2. Estimated Greenhouse Gas Emissions for Project Alternatives  
(tons, CO2e)**

Project Alternatives	Sources							
	Parcels Served	OWTS	Constr. Phase	30-yr O&M	Remain, OWTS (30-yr)	Water Savings	30-yr Total Tons	Tons per Parcel
<b>1</b>	0	360	314	2,956	-	-	3,270	9.08
<b>2</b>	0	360	627	3,687	-	-	4,315	11.99
<b>3</b>	176	184	240	2,911	2,206	-	5,357	14.88
<b>4a</b>	210	150	1,540	2,956	1,798	(-438)	5,856	16.27
<b>4b</b>	270	90	1,860	3,687	1,079	(-584)	6,042	16.78
<b>4c</b>	360	0	2,191	4,770	0	(-1,252)	5,709	15.86
<b>5a</b>	250	110	1,254	3,405	1,319	(-281)	5,697	15.83
<b>5b</b>	270	90	1,359	3,658	1,079	(-303)	5,793	16.09
<b>5c</b>	360	0	1,566	4,680	0	(-404)	5,842	16.23

Notes:

1. Alt. 1, assume 40% of OWTS upgraded voluntarily; 20% with pump and/or advanced treatment
2. Alt. 2, assume 80% of OWTS upgraded with pump and/or advanced treatment
3. Remaining OWTS not served by community system; GHG estimate per OWTS per Alt. 2
4. Water savings from use of recycled water; reduced GHG for MMWD raw water transmission
5. Water savings for Alt. 5a, 5b, 5c based on average irrigation season supply of recycled water only

## WATER CONSERVATION AND RECYCLING

Under **Alternatives 1** and **2** water conservation would potentially occur to a small degree to the extent that individual property owners choose to implement graywater systems as allowed under California Code Plumbing Code. Also water recycling would potentially occur where subsurface drip dispersal methods are used in a way where it can provide incidental yard irrigation benefits. Under **Alternative 3** secondary treated water would be dispersed to a leachfield, returning the water to the local watershed, but it would not provide any measureable water conservation benefit or water recycling.

Water recycling **Alternatives 4** and **5** would provide direct, measureable water recycling benefits realized through the reduction in irrigation water supplied to the golf course property from MMWD raw water supplies for either golf course irrigation (**Alternative 4**) or landscape, turf and open space irrigation (**Alternative 5**). **Table 7-3** summarizes the projected average annual water produced by each of the alternatives, in acre-feet and million gallons per year.

**Table 7-3. Recycled Water Produced – Average Annual Volumes**

Alternative	Recycled Water Produced			
	Irrigation Season (Apr-Oct)		Annual Total <sup>1</sup>	
	Acre-feet	Mgal	Acre-feet	Mgal
<b>Alternative 4a</b>	28.8	9.2	28.8	9.2
<b>Alternative 4b</b>	37.6	12.3	37.6	12.3
<b>Alternative 4c</b>	50.0	16.3	50.0	16.3
<b>Alternative 5a</b>	18.0	5.9	32.4	10.6
<b>Alternative 5b</b>	19.4	6.3	34.8	11.3
<b>Alternative 5c</b>	25.6	8.3	46.0	15.0

<sup>1</sup> For Alternatives 5a-5c, annual total includes recycled water for normal dry season irrigation, plus the amount produced during the normal wet season (November-March) that could be made available in dry winter periods for landscape/turf irrigation and other uses such as construction water, sewer cleaning, and certain types of water-dependent habitat restoration.

## LAND AREA NEEDS

This factor considers the impact of wastewater facilities on individual properties, public areas and other lands. **Alternative 2** would pose the biggest impact on individual properties in the service area through the need to modify and expand onsite wastewater systems on each property, affecting existing landscaping and other property improvements and activities. **Alternative 1** would have a similar effect, but not to the same degree. Neither of these alternatives would impact land uses elsewhere in the Woodacre-San Geronimo area.

**Alternative 3**, serving Woodacre (176 parcels), would involve the installation of small diameter gravity and pressure (STEP) effluent sewers in the local streets, with septic tanks and STEP pumping units on individual properties. The construction impacts in the streets could be minimized with the use of horizontal directional drilling methods for most of the pipeline work. The on-lot septic tanks and STEP pumping units would utilize the existing tanks or provide new tanks in generally the same location; the existing drainfield areas could be decommissioned. A more significant land use change under **Alternative 3** would be the community wastewater treatment and pumping facilities in the Park Street area (0.25 acres), the 1.5-acre Fire Road leachfield, and the connecting 0.4-mile long effluent force main to the leachfield site.

The land use impacts of water recycling **Alternatives 4** and **5** would include effects on individual properties, within street rights-of-way, and at the golf course property. On-lot impacts would include decommissioning/removal of existing septic systems and installation of new on-lot grinder pumps for a portion of the service area. Facilities in the street rights-of-way would include a combination of gravity sewers, pressure sewers, and one main lift station proposed at the intersection of Railroad Avenue and San Geronimo Valley Drive in Woodacre. Impacts at the golf course property would include land required for wastewater treatment facilities, transmission lines, and pumping facilities. **Alternative 4** would require about 3 to 6 acres for surface storage ponds, while **Alternative 5** would require 1.8 to 2.5 acres for sub-surface drip dispersal fields. Land where recycled water would be used for golf course, landscape, turf and/or open space irrigation is not considered a land use impact and, therefore, not included in the calculations below. **Table 7-4** quantifies and compares the respective facilities and land requirements for the various alternatives, along with the estimated reduction in land area

requirements associated with decommissioning of existing septic systems on individual properties served by the community facilities. The net effect on land area used for wastewater facilities is presented in the right-hand column, showing overall reductions (minus values) for all alternatives.

**Table 7-4. Land Area Impact Comparison – Water Recycling Alternatives**

Alternative	On-lot Facilities		Gravity & Pressure Sewers <sup>3</sup>	Wastewater Recycling Facilities			Net Land Impact (ac)
	OWTS Removed <sup>1</sup>	Grinder Pumps <sup>2</sup>		Treatment Plant Area <sup>4</sup>	Pipelines	Storage Ponds and Drip Dispersal Fields	
4a	210	40	26,565 lf		2,000 lf	125,350	
	(-9.64 ac)	0.09 ac	6.10 ac	0.2 ac	0.46 ac	2.9 ac	0.11 ac
4b	270	115	36,740 lf		6,000 lf	188,600	
	(-12.4 ac)	0.26 ac	8.43 ac	0.2 ac	1.38 ac	4.33 ac	2.2 ac
4c	360	160	36,740 lf		6,000 lf	257,030	
	(-15.53 ac)	0.37 ac	8.43 ac	0.2 ac	1.38 ac	5.9 ac	0.75 ac
5a	250	50	26,885 lf		4,000 lf	61,000	
	(-11.5 ac)	0.11 ac	6.17 ac	0.3 ac	0.91 ac	1.8 ac	(-2.21)
5b	270	115	36,740 lf		4,500 lf	70,000	
	(-12.4 ac)	0.26 ac	8.58 ac	0.3 ac	1.03 ac	1.9 ac	(-0.33)
5c	360	160	36,740 lf		5,000 lf	87,000	
	(-15.53 ac)	0.37 ac	8.58 ac	0.3 ac	1.15 ac	2.5 ac	(-2.63)

<sup>1</sup> Assumes average 2,000 ft<sup>2</sup> area per septic system

<sup>2</sup> Assumes average 100 ft<sup>2</sup> area per grinder pump unit

<sup>3</sup> Assumes average 10 ft<sup>2</sup>/lf of pipeline; includes collection lines plus force main(s) to treatment site

<sup>4</sup> Includes treatment plant and also, for Alternatives 5a-5c, area for treated water storage tanks and dispersal/irrigation pumping facilities.

## COSTS

The estimated capital cost and operation and maintenance (O&M) cost for the various wastewater project alternatives are summarized in **Table 7-5**. Supporting cost information is itemized for each alternative in preceding individual sections and in the appendices. A total project cost cannot be provided for No Project alternative. However, based on experience in Marin County with existing properties, expenses to individual property owners for upgrading and on-going maintenance of functional and compliant onsite wastewater systems (predominantly alternative systems) include typical capital costs in the range of \$30,000 to \$70,000, and annual costs of \$500 to \$1,500 per parcel for individual system inspection, maintenance, monitoring and reporting under County operating permit, as applicable. On average, these costs would be similar to the estimated per parcel costs developed for **Alternative 2**. The cost comparison shows **Alternative 5c** and **Alternative 3** (Fire Road Community Leachfield) to have the lowest projected capital cost per parcel, both between \$37,500 and \$38,000. Alternative 3 has the lowest projected annual O&M cost per parcel (\$885); however, it would offer only limited capacity, serving about half of the entire study area, with the remaining properties left to be addressed individually (No Project) or under an Onsite Management Program (**Alternative 2**).

The most cost effective alternative is water recycling **Alternative 5c**, which includes service to the entire study area; it has estimated capital costs of approximately \$37,500/parcel and annual O&M costs of \$1,144/parcel.

**Table 7-5. Project Alternatives Cost Comparison**

Alternative	Parcels	Capital Costs (\$)			Annual O&M Costs (\$)			
		Total	Per Parcel	Rank <sup>1</sup>	Total	Per Parcel	Rank <sup>1</sup>	
1	No Project	-	35,000 to 70,000	8		500 to 1,500	2	
2	Onsite Upgrades & Management Program	360	19,193,915	53,316	8	348,480	968	2
3	Woodacre Fire Road Community Leachfield	176	6,629,839	37,670	2	159,610	907	1
4a	Woodacre Only	210	9,563,777	45,542	6	291,540	1,356	8
4b	Partial (75%) Woodacre-San Geronimo	270	12,652,447	46,861	7	346,564	1,260 <sup>2</sup>	6
4c	Full Woodacre-San Geronimo	360	14,323,558	39,788	4	\$366,463	1,004 <sup>2</sup>	4
5a	Woodacre Only	250	9,792,362	39,169	3	348,805	1,368 <sup>2</sup>	9
5b	Partial (75%) Woodacre-San Geronimo	270	11,696,245	43,319	5	365,860	1,330 <sup>2</sup>	7
5c	Full Woodacre-San Geronimo	360	13,505,643	37,516	1	415,575	1,144 <sup>2</sup>	5

<sup>1</sup> Lowest cost = Highest Ranking (1) <sup>2</sup> Cost share includes additional allowance of 5 ESDs for golf course clubhouse

Table 7-6 provides a comparative summary of the estimated project costs attributable to the production or recycled water for the several variations under Alternatives 4 and 5. The costs are broken down by (a) capital costs associated with the inclusion of tertiary treatment facilities, transmission pipelines and storage facilities (ponds and tanks) (b) the portion of annual operation and maintenance (O&M) associated with recycled water production. Annual O&M costs are presented as present worth value, calculated for a 30-yr operating period at a 5% discount rate. The right hand column displays the estimated cost of recycled water per acre-foot, using the estimated average annual recycled water production for each alternative, as presented in Table 7- 3. For Alternatives 5a, 5b and 5c, costs are presented for the low (irrigation season only) and high (total annual) estimates of recycled water production. Supporting assumptions and calculation worksheets are provided in **Appendix H**.

**Table 7-6. Estimated Costs for Recycled Water, 30-yr Basis  
(2019 \$)**

Recycled Water Alternatives	Average Annual Recycled Water Produced	Capital Costs for Water Recycling Components		Annual Recycling O&M Cost Present Worth <sup>1</sup>	Total 30-yr Cost for Recycled Water Production	Estimated Recycled Water Cost per Acre-foot
		Tertiary Treatment Facilities	Pipelines & Storage			
<b>4a</b>	28.8	598,000	2,054,130	1,702,990	4,355,120	<b>\$ 5,041</b>
<b>4b</b>	37.6	672,750	2,907,775	2,024,382	5,604,907	<b>\$ 4,969</b>
<b>4c</b>	50.0	747,500	3,431,025	2,140,683	6,319,208	<b>\$ 4,213</b>
<b>5a</b>	18.0	598,000	882,050	2,305,620	3,785,670	<b>\$ 7,011</b>
	32.4					<b>\$ 3,895</b>
<b>5b</b>	19.4	672,750	907,465	2,418,320	3,998,535	<b>\$ 6,870</b>
	34.8					<b>\$ 3,830</b>
<b>5c</b>	25.6	747,500	986,700	2,760,187	4,494,387	<b>\$ 5,852</b>
	46.0					<b>\$ 3,257</b>

<sup>1</sup> Present worth calculated for 30 years at 5% discount rate.

## COMPARATIVE SUMMARY AND RANKING

An overall comparison is presented here between the nine project alternatives, taking into consideration the various factors presented in this section. Relative numerical ratings (lowest=1 to highest=9) were assigned to each alternative for each factor as discussed below. The scoring was based on a combination of objective information (e.g., costs) and subjective best professional judgment. Results are displayed in **Table 7-6**. The cumulative scores provide the basis for overall comparative ranking of alternatives, 1 through 9, at the bottom of the table.

## Regulatory Compliance

Project alternatives were evaluated with respect to their ability to meet public health and water quality standards, along with the level of standard applicable to the project. Projects were ranked in order of increasing environmental quality standards, and points were assigned according to rank, from 1 (minimum) to 9 (maximum). The No Project alternative, which would have the greatest degree of non-compliance, was assigned the lowest ranking and point score. Increasingly higher environmental standards would be met by **Alternatives 2** through **5c**, and they were ranked and scored accordingly. Higher ranking was given to water recycling **Alternatives 4** and **5** meeting tertiary treatment standards. Also between the water recycling alternatives, higher ranking was given based on the total number of properties in the study area able to be served.



## Environmental Impacts

Projects were preliminarily ranked in order of decreasing impacts on the natural environment based on best professional judgment and assigned points according to rank. The least impact project was assigned the highest score (9). This assessment and ranking will be reviewed refined in the EIR process.

## Reliability

Projects were subjectively ranked in order of increasing operational reliability to address community wastewater needs consistent with applicable requirements, including provisions for emergencies and other reasonable contingencies. The most reliable project was assigned the highest score.

## Energy Use and Greenhouse Gases

Project alternatives were ranked in order of decreasing energy requirements and production of greenhouse gases for construction, on-going operation and maintenance, and avoided raw water transmission attributable water recycling. The scoring was based on the 30-yr GHG estimates in Table 7-2. Higher points correspond to projects with lower net GHG emissions.

## Water Conservation and Recycling Benefits

All water recycling projects were scored higher than non-recycling alternatives, and between **Alternatives 4 (a-c)** through **5 (a-c)**, scores were assigned according to the projected amount of recycled water produced for replacement of raw water supplies used for golf course, landscape or other irrigation. Onsite management **Alternative 2** was ranked ahead of **Alternative 3** (Fire Road Leachfield) on the basis of potentially offering greater potential for water savings through effective onsite use of graywater or subsurface drip dispersal for yard irrigation.

## Land Area Needs

Project alternatives were subjectively ranked in order of decreasing impacts on land area needs, based on the amount of land that would be converted or dedicated to wastewater treatment and/or disposal uses.

## Costs

Lastly, project alternatives were ranked by costs per parcel, with separate ranking and points assigned for (a) capital costs and (b) annual operation and maintenance costs per **Table 7-5**. Highest points were given to least cost alternative. The lowest points were given to the No Project alternative. This is due to the fact that, although no information has been developed on the total cost of this alternative, there is a strong likelihood that the future cost of individual compliance for any given property owner could easily exceed the estimated per parcel costs for the any of the other community-based project alternatives.

**Table 7-7. Numerical Rating of Alternatives\***

	Non-Recycling Alternatives			Water Recycling Alternatives San Geronimo Golf Course Property					
	1 No Project	2 Onsite Mgmt	3 Fire Road	With Ponds			Without Ponds		
				4a	4b	4c	5a	5b	5c
				Woodacre Only	Partial (75%)	Full (100%)	Woodacre Only	Partial (75%)	Full (100%)
<b>Regulatory Compliance</b>	1	2	3	4	7	9	5	7	9
<b>Environmental Impacts</b>	1	2	3	6	5	4	9	8	7
<b>Reliability</b>	1	2	3	4	7	9	5	7	9
<b>Energy Use &amp; GHG</b>	9	8	7	2	1	4	6	5	3
<b>Water Conservation</b>	1	3	2	7	8	9	4	5	6
<b>Land Area Needs</b>	2	1	3	6	4	5	8	7	9
<b>Capital Cost</b>	2	2	8	4	3	6	7	5	9
<b>Annual O&amp;M Cost</b>	8	8	9	2	4	6	1	3	5
<b>TOTAL</b>	<b>25</b>	<b>28</b>	<b>38</b>	<b>35</b>	<b>39</b>	<b>52</b>	<b>45</b>	<b>43</b>	<b>53</b>
<b>RANKING**</b>	<b>9</b>	<b>8</b>	<b>6</b>	<b>7</b>	<b>5</b>	<b>2</b>	<b>3</b>	<b>4</b>	<b>1</b>

\*Points assigned from 1 to 9, low to high for each factor

\*\*Ranking with 1 as best (highest point score)

## Apparent Best Alternative

The comparative analysis shows **Alternative 5c** to be the highest ranking, most cost effective and “apparent best” alternative. It would provide capacity to serve essentially all properties within the designated Woodacre and San Geronimo service areas (360 parcels), meeting an important project objective. The estimated capital cost per parcel (\$37,516) is the lowest, and the estimated annual O&M costs (\$1,144) per parcel is rank near the middle among the alternatives evaluated. Projected water recycling/water conservation benefits for **Alternative 5c** are the highest among the alternatives without ponds. **Alternative 4c** ranks second highest in preference and would provide the greatest amount of water conservation benefit for golf course operations, at the lowest cost per acre-foot; it is fourth lowest in estimated capital cost on a per parcel basis.

## SECTION 8: RECOMMENDED FACILITIES PROJECT PLAN

### WATER RECYCLING FACILITIES

#### Description, Layout and Preliminary Design Criteria

The recommended project (“apparent best alternative”) is **Alternative 5c**, which includes collection, treatment, and recycling of wastewater for turf irrigation at the San Geronimo Golf Course property (Clubhouse Parcel), with capacity to serve up to approximately 360 parcels in the Woodacre-San Geronimo study area. The system would have a capacity to accommodate an estimated average daily flow of approximately 44,000 gpd and peak daily flow of up to 60,000 gpd. The nominal sizing of the treatment system would be 50,000 gpd. Under average year rainfall conditions, the project would produce approximately 25.6 acre-feet (8.3 million gallons) of disinfected tertiary recycled water for dry season (April-October) irrigation of approximately 9 acres of landscaping, open space or golf course turf; it would also provide an additional 20 acre-feet (15 million gallons) of recycled water for irrigation and other uses during the normal wet season months of November-March. The recycled water available for irrigation uses would represent an approximate 17% reduction in the historical volume of raw water supplied to the property by MMWD for golf course irrigation.

The main facilities include: (a) wastewater collection systems extending throughout the Woodacre and San Geronimo service areas using a combination of conventional gravity sewers and pressure sewers; (b) sewage force mains from Woodacre and San Geronimo areas to the treatment plant location in the golf course clubhouse area; (c) tertiary recycled water treatment plant located in an approximately 10,000 ft<sup>2</sup> area in one of three possible sites on the Clubhouse Parcel; (d) below-ground storage tanks with capacity for approximately 60,000 gallons of recycled water and associated dispersal and irrigation pumping systems; (e) recycled water irrigation facilities extending over approximately 9 acres of landscaping, open space and/or golf course turf area on the golf course property; (f) winter season dispersal of tertiary treated water to approximately 2.5 acres of land on the Clubhouse Parcel. **Figure 8-1** is a map showing the location and layout of key facilities.

#### ***Wastewater Collection***

New wastewater collection systems would be installed throughout the Woodacre and San Geronimo communities using a combination of conventional gravity sewers and pressure sewers. All existing septic tanks and disposal systems would be decommissioned and properly abandoned (by the owner) in accordance with County Regulations for septic tank abandonment. This normally includes pumping out the tank, breaking the tank bottom for drainage, and backfilling the tank with sand or soil. Sewage pipes can either be removed or abandoned in place.

The recommended features and layout of wastewater collection facilities for Woodacre and San Geronimo are shown, respectively in **Figures 8-2** and **8-3**, and summarized below.

**Woodacre.** The recommended sewage collection method for Woodacre is a conventional gravity system for most of the area, with an underground main lift station located at the northeast corner of Railroad Avenue and San Geronimo Valley Drive, and a force main from the

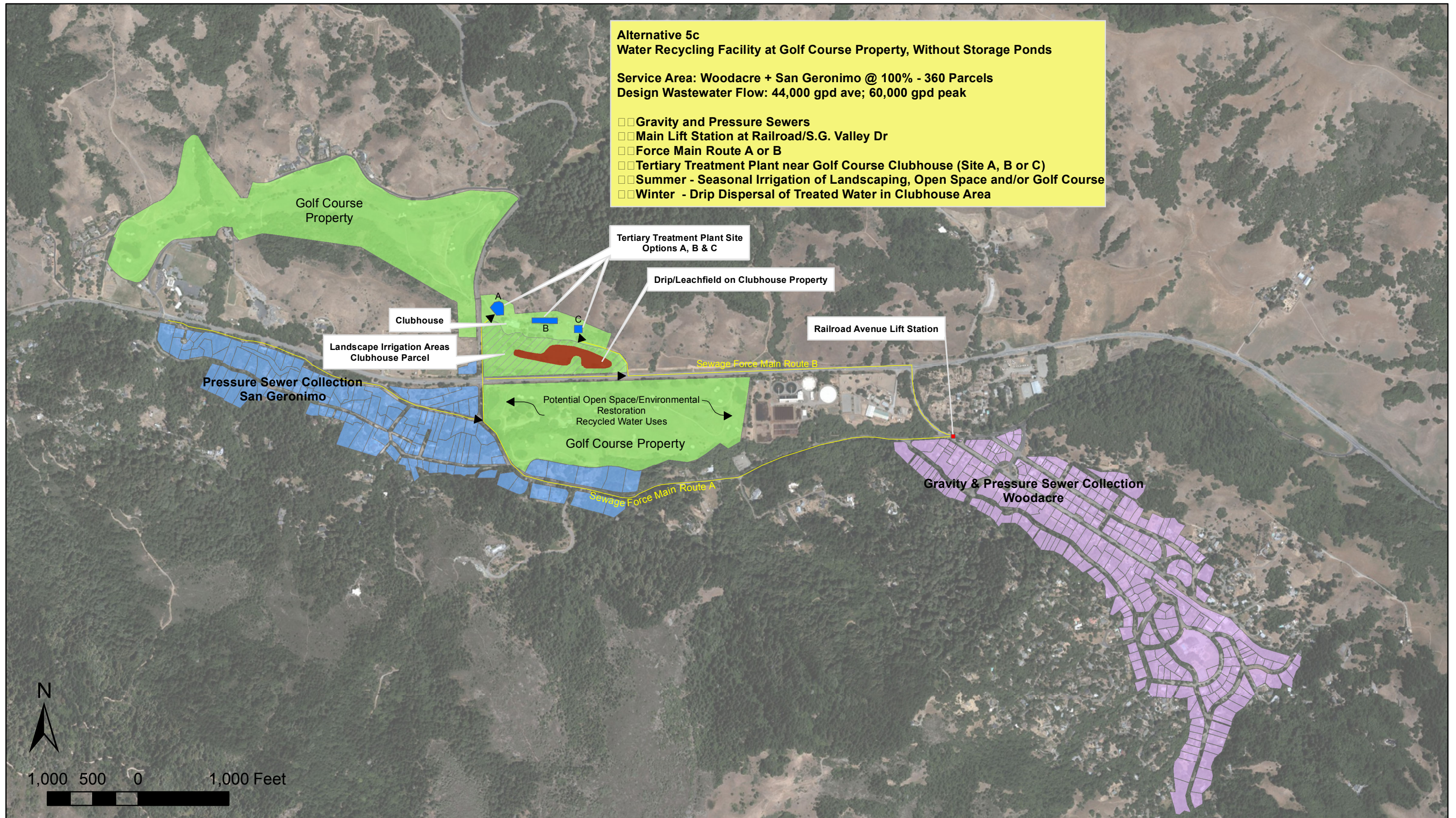

DATE:	2/4/2019
PROJECT:	WOODACRE WW
PROJECT NO:	1600073
DRAWN:	MF
APPROVED:	NH



**RECOMMENDED PROJECT ALTERNATIVE 5c**

**FIGURE 8-1**

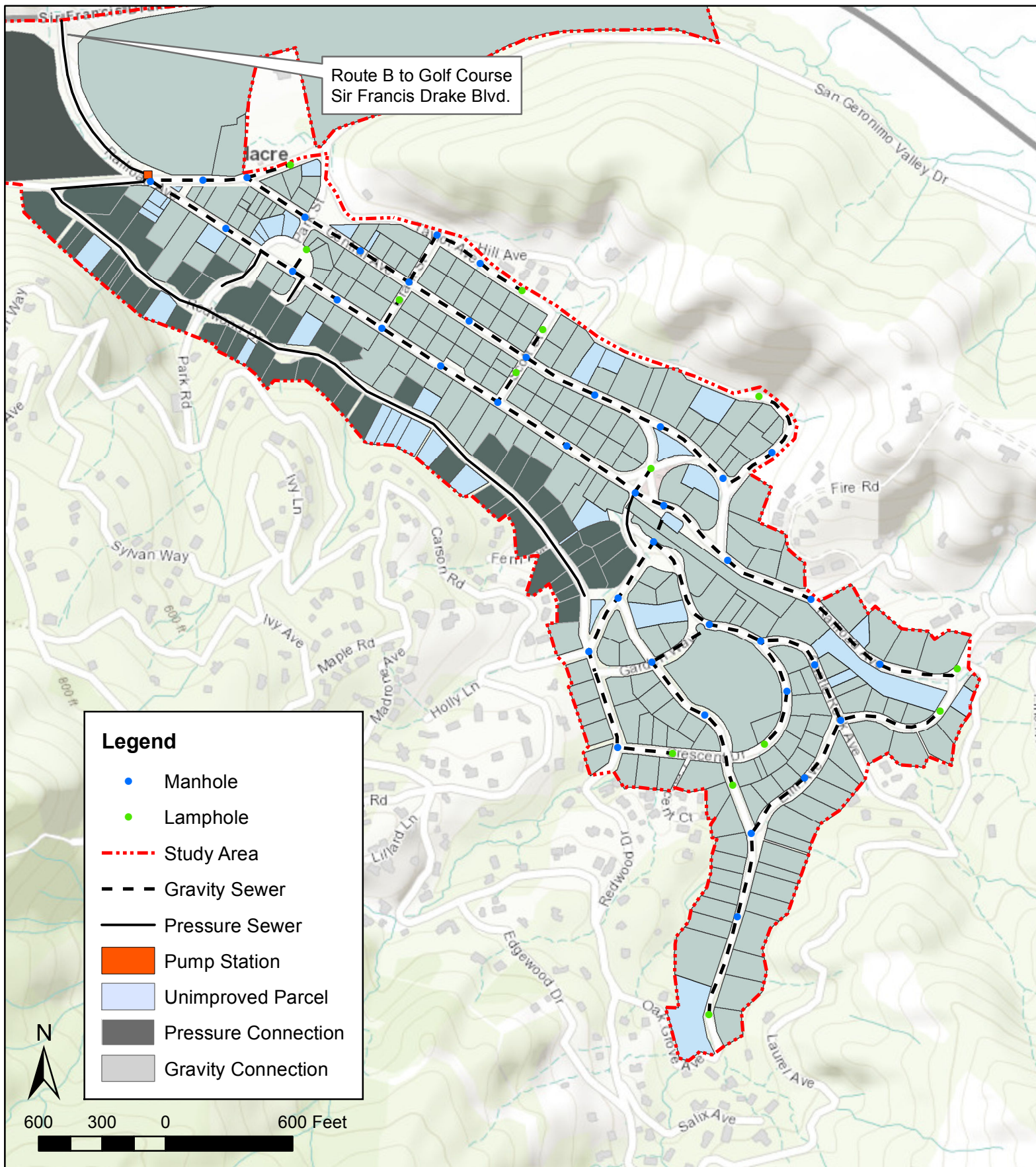

Route B to Golf Course  
Sir Francis Drake Blvd.

**Legend**

- Manhole
- Lamphole
- - - Study Area
- - - Gravity Sewer
- Pressure Sewer
- Pump Station
- Unimproved Parcel
- Pressure Connection
- Gravity Connection

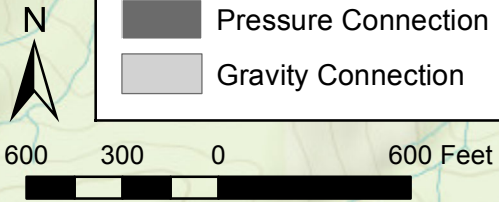

DATE:	12/20/2016
PROJECT:	WOODACRE WW
PROJECT NO.:	1600073
DRAWN:	DD
APPROVED:	NH



**WOODACRE  
GRAVITY SEWER  
SYSTEM PLAN**

**FIGURE  
8-2**

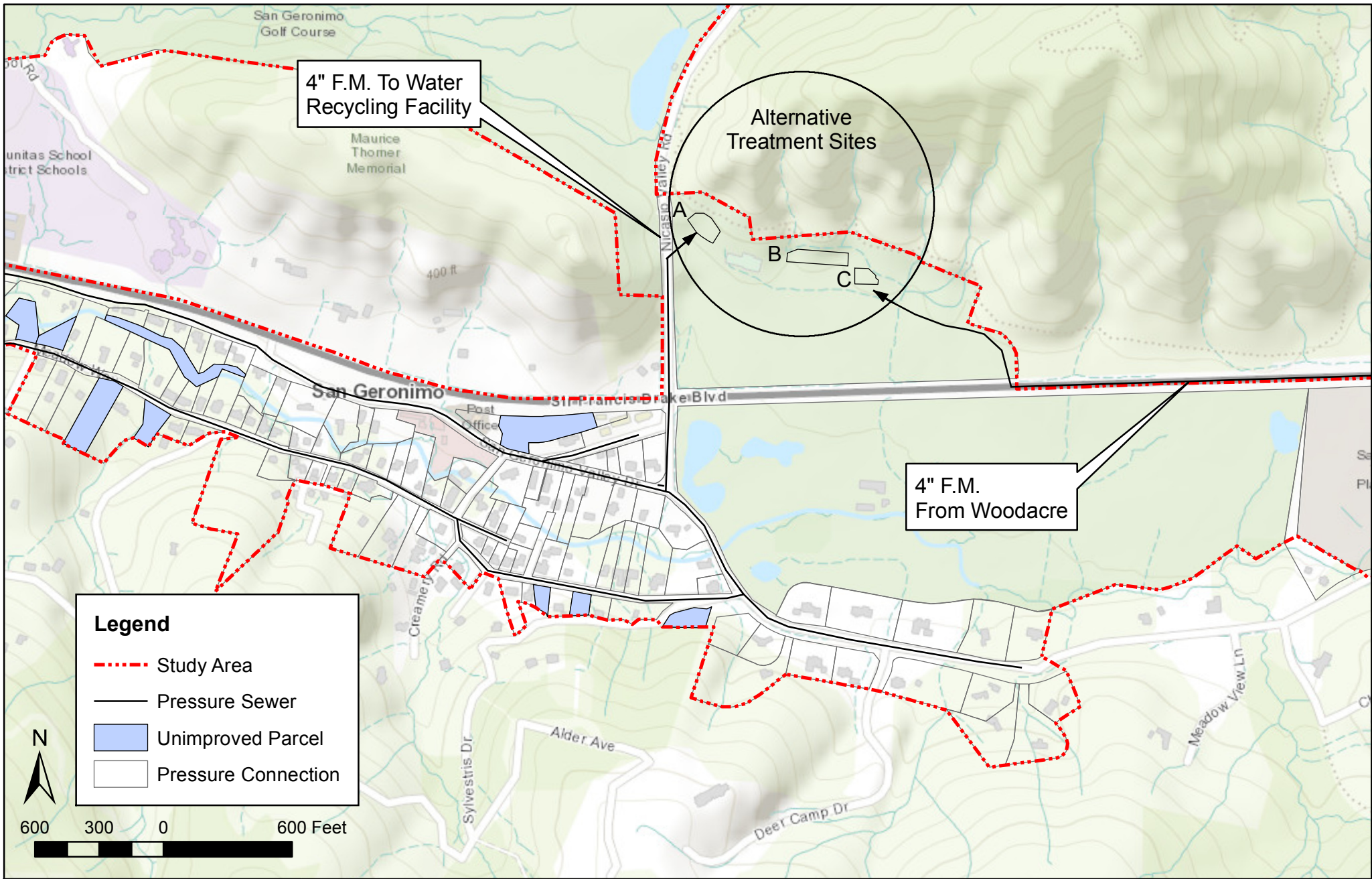

DATE:	12/20/2016
PROJECT:	WOODACRE WW
PROJECT NO.:	1600073
DRAWN:	DD
APPROVED:	NH



## SAN GERONIMO PRESSURE SEWER SYSTEM PLAN

**FIGURE  
8-3**

lift station to the treatment plant at San Geronimo Golf Course. Because of the undulating terrain, a pressure sewer would be used for properties along Redwood Drive, tying in at the main lift station.

- **Gravity Sewers.** Properties served by gravity connections would have a 4-inch lateral extended to the front property line, and the property owner would be responsible for installing a new 4-inch house plumbing drain to the lateral provided. The gravity sewers in the street right-of-way would consist primarily of 6-inch diameter sewer pipes, typically 4 to 5-feet deep, with manholes located about every 400 feet and at intersections and major grade changes. There may be some use of 8-inch diameter sewers depending on the final sewer layout. Gravity sewers must maintain a constant downhill grade and would be installed using open-cut trenching methods.
- **Pressure Sewer.** A pressure sewer is a small diameter pipeline (e.g., 2 to 4 inches diameter), which is installed following the profile of the ground or street. Burial depths usually have a 30-inch minimum cover. This sewer design is the preferred approach for properties along Redwood Avenue due to the undulating grade of the street and the location of many properties below the street grade, requiring pumps to lift the sewage from the house to the sewer. Each home would have a small grinder pump unit to discharge to the pressure main via a small diameter service lateral (typically 1.25-inch diameter). The pump grinds the solids in the wastewater into slurry in the manner of a kitchen sink garbage grinder. Grinder pumps serving individual homes would be one horsepower and come in standard package units consisting of 30-inch diameter by 5-ft to 6-ft deep polyethylene basins (see **Appendix D**). The grinder pumps and service lateral would be provided as part of the project; the property owner would be responsible for re-routing and connecting their building sewer to the new grinder pump; they would also be responsible for providing the electrical power for pump operation.
- **Main Lift Station.** A main lift station would be located in the north end of the Woodacre service area on the northeast side of the intersection of Railroad Avenue and San Geronimo Valley Drive. It would be the terminal collection point for the gravity sewer lines as well as the pressure sewer main from Redwood Avenue. The lift station would be located within County road right-of-way and would consist of a buried tank (wet well), duplex submersible pumps, electrical controls, and an emergency generator. In addition to redundant pump capacity and emergency power supply, the lift station would be designed with emergency storage capacity for minimum six hours of sewage flow and telemetry alarm and control features for remote monitoring and operation.
- **Force Main.** A 4-inch diameter force main would run from the main lift station to the proposed treatment plant location at the San Geronimo Golf Course Clubhouse area. Two alternate routes have been identified: (a) Route A via San Geronimo Valley Drive, approximately 7,160-feet long; and (b) Route B via Railroad Avenue and Sir Francis Drake Boulevard, approximately 5,650-feet long. Both routes are feasible, but Route B is shorter and less costly. They also differ in the fact that Route A would parallel the San Geronimo Creek corridor for most of its length, and Route B would cross San Geronimo Creek at Railroad Avenue and then remain away from the creek for the remaining distance. Horizontal directional drilling methods would be used for either pipeline option. Selection of the preferred route should be made following completion of environmental review.



**San Geronimo.** The recommended sewage collection method for San Geronimo is a pressure sewer system. The pressure sewer network would consist of 2-inch, 3-inch and 4-inch diameter pipes, running west-to-east on Sir Francis Drake Boulevard, San Geronimo Valley Drive and Meadow Way, eventually connecting together at San Geronimo Valley Drive. From there the sewage flow would be routed in a 4-inch force main northerly along Nicasio Valley Road, across Sir Francis Drake Boulevard before entering the Clubhouse Parcel and being routed to the selected wastewater treatment plant site. Due to the flat and undulating terrain, which slopes steadily downstream, away from the golf course, analysis shows that gravity sewers would be a significantly more expensive option for San Geronimo, requiring deep trenching and multiple lift stations in the community.

The preliminary collection system plan includes about 10,200 feet of pressure sewer mains with individual grinder pumps and pressure laterals at each property. Pressure sewer lines would be installed primarily using horizontal directional drilling methods. There would be one section of pressure sewer that crosses San Geronimo Creek; this would be at the bridge near Meadow Way. The crossing would be accomplished using a ductile iron sleeve (for support, protection and double-containment) secured on the downstream side of the bridge deck adjacent to an existing water main crossing. There would be shut-off valves on both sides of the bridge crossing for maintenance and emergency purposes. This is the same creek crossing that would be required for Woodacre force main Route A; the San Geronimo and Woodacre lines would join into a single pipeline crossing if Woodacre Route A is selected.

### **Wastewater Treatment**

**Treatment Objectives.** The wastewater treatment facilities would be designed and operated to produce disinfected tertiary recycled water meeting the requirements of California Code of Regulations, Title 22 Water Recycling Criteria. Recycled water meeting these standards is acceptable for unrestricted landscape irrigation, including golf course irrigation, as well as other water recycling uses. Effluent constituent concentrations for the water recycling facility are listed in **Table 8-1**, based on Title 22 standards and effluent limitations contained in the *State Water Board Order WQ 2014-0153-DWQ (Table 4)* for MBR and similar treatment systems. In addition to meeting turbidity and total coliform limits set by Title 22, the selected treatment system would be designed with denitrification features to reduce final effluent nitrogen concentration by 50% compared to the influent concentration. **Figure 8-4** provides a process schematic of the proposed water recycling system.

**Table 8-1. Proposed Effluent Limits**

<b>Constituent</b>	<b>Average</b>	<b>Maximum</b>
Flow (gpd)	44,000 gpd (monthly)	-
BOD (mg/L)	30 (monthly)	45 (7-day ave.)
Total Suspended Solids (mg/L)	30 (monthly)	45 (7-day ave.)
Turbidity (NTU)	0.2 <sup>1</sup>	0.5 <sup>2</sup>
Total Coliform (MPN/100 ml)	2.2 <sup>3</sup>	23 <sup>4</sup>
Total Nitrogen (mg/L)	50% Removal	-

<sup>1</sup> Not to be exceeded more than 5% of time in 24-hr period;

<sup>2</sup> Not to be exceeded at any time

<sup>3</sup> Median for seven day period

<sup>4</sup> Not to be exceeded more than once in any 30-day period.

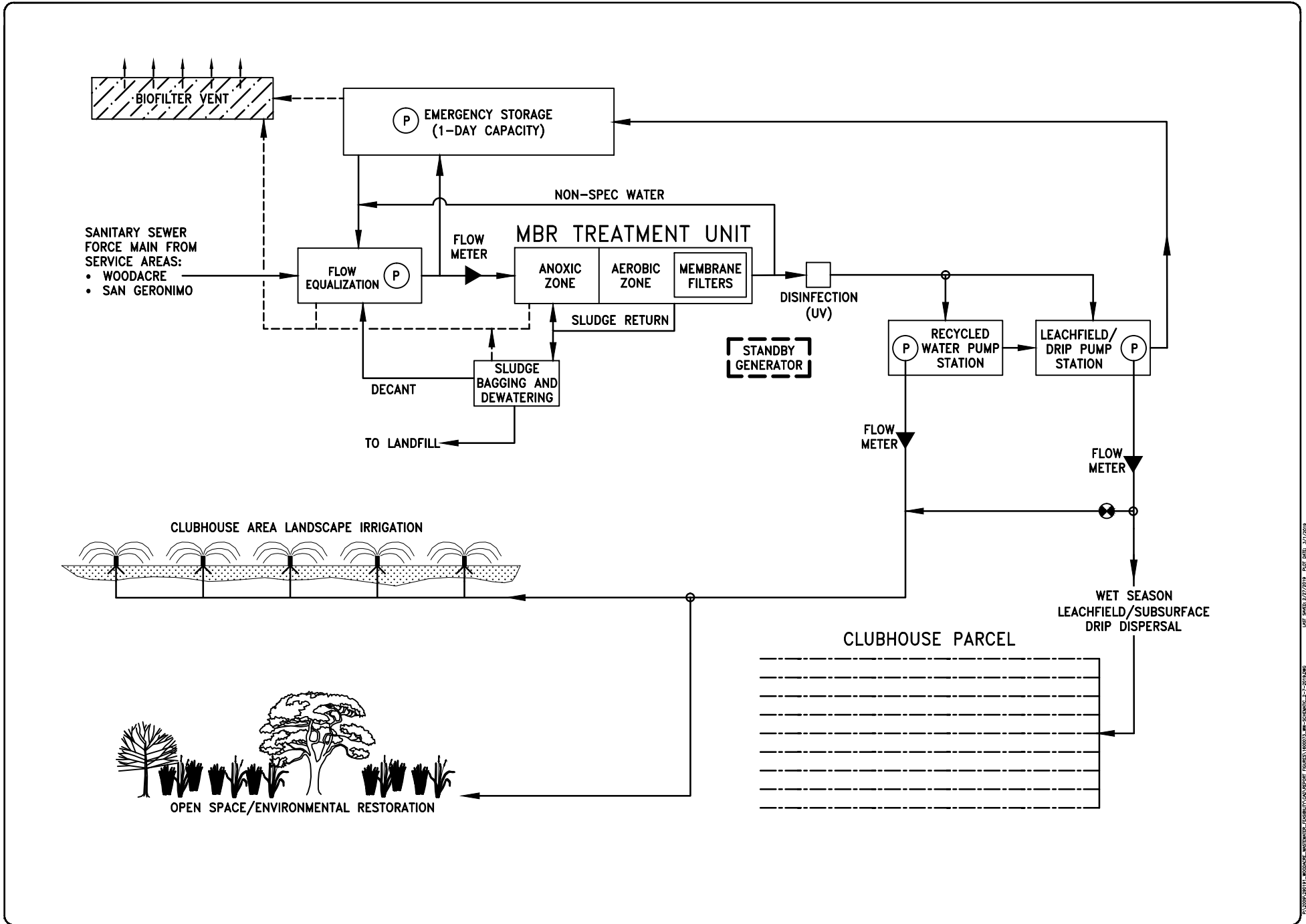

P:\3000\3011\WOODACRE\_SAN GERONIMO FLATS\WATER RECYCLING\PROJECTS\WATER RECYCLING\SCHEMATIC\_2-7-2016.dwg  
 AUT: 2/22/2016 10:58:19 AM PAGE: 8-4

Site	Rev.	Date	By	Description	Appr'd

Design:	NH
Drawn:	MF
Checked:	NH
Appr'd:	NH

**Treatment Plant Site.** Figure 8-5 shows the general layout of wastewater facilities on the Clubhouse Parcel, including three alternate sites identified for placement of the wastewater treatment/recycling plant. These are: (a) Site A, in the unpaved space adjacent to the area used for community gardens; (b) Site B, in the upper, paved parking area immediately east of the Clubhouse facility; and (c) Site C on the gently sloping hillside area immediately northwest of the Clubhouse facility. Each site has sufficient land area to accommodate the treatment plant. The sites are outside of the Stream Conservation Area for San Geronimo Creek, but do not provide a high degree of natural screening from public roads. Additional screening with vegetation and/or structural elements would be needed. The identified treatment plant sites have good vehicular access either from Sir Francis Drake Boulevard or Nicasio Valley Road. A detailed siting analysis and comparison of pros and cons between the alternate locations has not been conducted, but would be done in connection with overall development planning for future uses of the Clubhouse Parcel.

The treatment plant would occupy an area of approximately 10,000 square feet, including above-ground and below-ground treatment and storage tanks, blowers, pumps, piping, covered sludge dewatering and bagging area, biofilter venting and appurtenances. There would be a control building (approximately 600 square feet) to house electrical/mechanical controls, UV disinfection equipment, a small office, laboratory area, and storage space for equipment and supplies. Allowance has also been included in project cost estimates for a covering structure to screen main above-ground elements of the treatment facility. The structure could be designed to resemble an approximately 3,000 square foot house or barn. The treatment plant area would have parking and vehicle access and would be fenced.

**Treatment Processes.** Figure 8-6 shows the preliminary design layout of the treatment facilities and processes, using Site C for illustration purposes. The key facilities are described below.

- **Flow Equalization and Emergency Storage Tanks.** Influent sewage from the wastewater collection system would enter the treatment plant in a below-ground flow equalization (EQ) tank where peak surges in sewage flows that occur throughout the day are evened-out. The EQ tank also provides some settling and collection of grit and other solids. Duplex pumps, operating on timed-dosing, would deliver a steady approximately equal flow to the MBR treatment unit for optimum performance. The EQ tank would be sized equal to approximately half the daily peak flow (e.g. 30,000 gallons). The EQ tank would be aerated at a rate sufficient to keep the sewage from becoming anaerobic (septic), with the air vented to the biofilter odor control facilities.

Per Title 22 requirements, an emergency storage tank sufficient to store at least one day of incoming sewage flow (peak of 60,000 gallons). from the service area would be provided. It would be situated and designed to take water as direct inflow from the collection system, pumped discharge from the EQ tank, or high water gravity overflow from the EQ tank.

- **Membrane Bioreactor (MBR).** From the EQ tank the raw sewage would be pumped into the MBR treatment unit, consisting of an above-ground tank which includes an anoxic zone and aerated zone, pumps, electrically-actuated valves, blowers, level controls, a programmable logic controller (PLC) and ultra-filtration membrane filter. The sewage is mixed with recirculated mixed liquor in the anoxic cell and then flows to the aeration cell. In the aeration cell, the wastewater is aerated through a grid of fine bubble

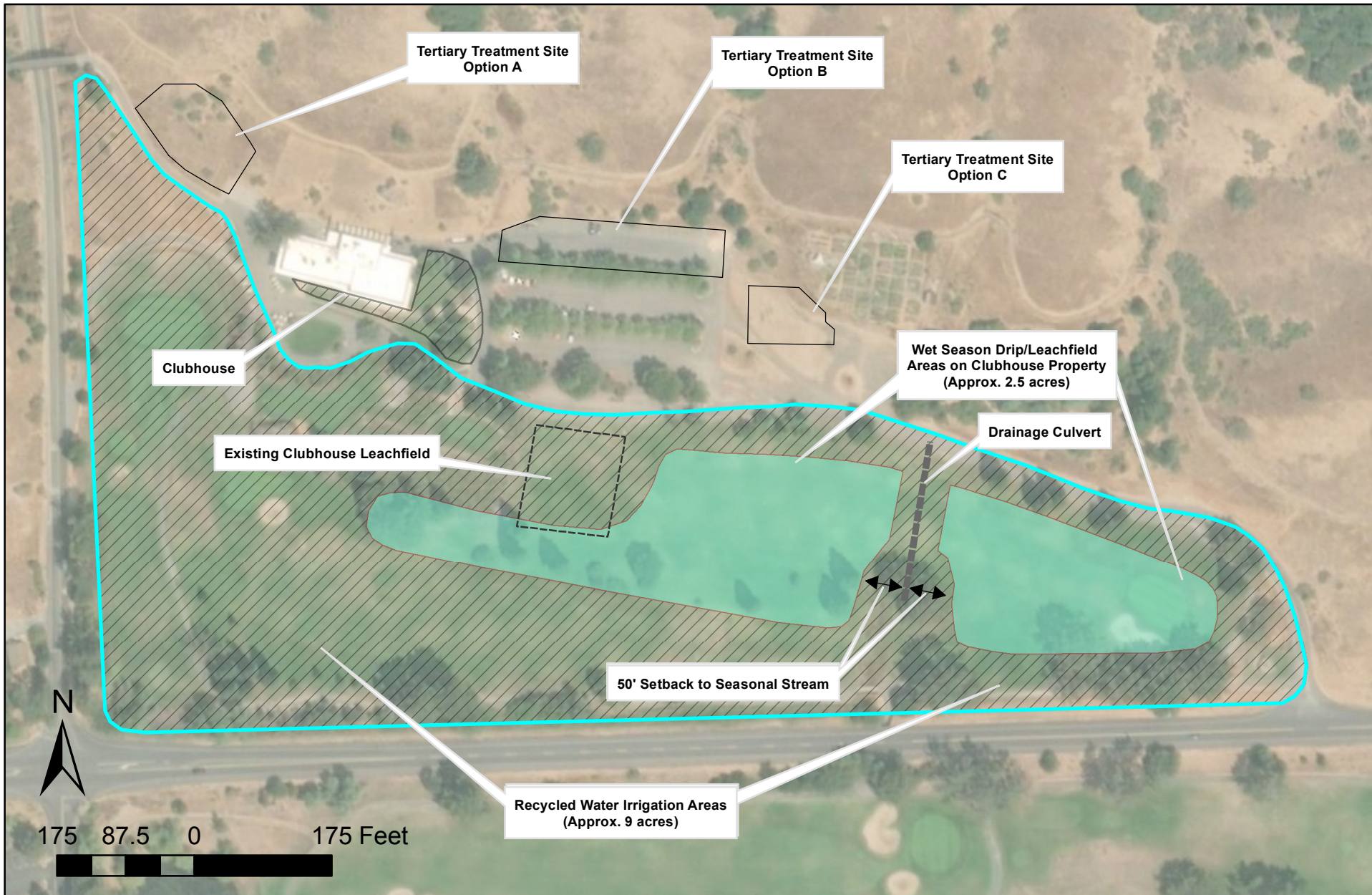

DATE: 2/14/2019  
 PROJECT: WOODACRE WW  
 PROJECT NO: 1600073  
 DRAWN: MF  
 APPROVED: NH



**WASTEWATER FACILITIES  
 ON CLUBHOUSE PARCEL**

**FIGURE  
 8-5**



VENT	
PIPE WITH FLOW DIRECTION	
FENCE	xxxxxx
PUMP	
MANHOLE	
VALVE	
DRAIN	
ABOVEGROUND STRUCTURE	
BELOWGROUND STRUCTURE	
STRUCTURAL SCREEN	

DATE:	2/14/2019
PROJECT:	WOODACRE WW
PROJECT NO.:	1600073
DRAWN:	TC
APPROVED:	NH

  
**QUESTA**
  
 ENGINEERING CORP.

Civil Environmental & Water Resources  
 170 228-8814  
 FAX: 228-248-2425  
 questacorp.com  
 P.O. Box 70356 1220 Brickyard Cove Road Point Richmond, CA 94807

## TERTIARY TREATMENT FACILITY EXAMPLE LAYOUT

**FIGURE  
8-6**

diffusers connected to positive displacement blowers. The ultra-filtration membranes are immersed directly in the aerated mixed liquor and are connected to the suction side of a centrifugal pump (or pumps). The clean permeate is drawn through the membranes and discharged to the disinfection system. The dimensions of a 50,000 gpd MBR unit would be approximately 40-ft long, by 8-ft wide by 12-ft high. The MBR would be vented partially to the biofilter odor control facilities and partially to the atmosphere, which is a common practice for odor control.

The MBR process is well suited for the project because of the small area requirement, relatively low demands for operator control of the system (based on ease of automation), commercial availability, and acceptance of the technology by the State Water Board's Division of Drinking Water (DDW) for water recycling applications. Background information and technical details on the MBR treatment process are covered in an EPA Fact Sheet and example manufacturer information, provided in **Appendix E**.

**UV Disinfection.** Treated water from the MBR would be passed through a UV light disinfection system housed in the control building. The system would include dual units, capable of treating the entire flow with one unit out of operation. The selected equipment would be from among several types of UV systems listed and accepted by the DDW as an approved technology under Title 22. An example UV system suitable for the project is provided in **Appendix E**. Field testing of the UV system would be required at the time of installation to validate conformance with Title 22 disinfection/virus inactivation requirements. The proposed equipment would include sensors to continuously monitor the effluent flow rate and UV transmittance in order to control the UV dose by varying the power output (i.e., UV intensity). The UV equipment also employs a programmable automatic sleeve-wiping mechanism to regularly maintain the unit against bulb fouling.

- **Sludge Handling.** Sludge would be withdrawn periodically from the MBR anoxic tank and collected in an adjacent, covered sludge bagging and dewatering area. Decant from the sludge dewatering facilities would be collected and drained back to the EQ tank. The bagged sludge would be hauled for disposal at an approved sanitary landfill. Dry sludge production is estimated to be approximately 50 pounds per day. Sludge bags, when filled, would be retained onsite in a covered area for several weeks of drying. Hauling of dry sludge (50-lb bags) would occur every few months. Manufacturer information and photos of typical sludge bagging system suited to this project is provided in **Appendix E**.
- **Biofilter Odor Control.** Odor control facilities would be provided for air vented from the EQ tank, portions of the MBR unit, sludge bagging/dewatering area and emergency storage tank. Odors would be controlled through capture and filtering through an organic media bed (biofilter) designed to remove volatile organic compounds, primarily hydrogen sulfide and methane. Activated carbon filters may be used at selected equipment locations, where practicable. The odor collection system would include various piping, ductwork and fans to create a vacuum condition at each process facility and move the foul air to and through the filter ("scrubber") media, which would be located on the back side (uphill) of the MBR treatment unit. The biofilter bed would be approximately 30 inches deep with a minimum surface area of about 300 ft<sup>2</sup>. The bottom 12 inches would contain plastic pipes or chambers for air distribution, gravel bedding and packing around the chambers, covered with an 18-inch depth of organic-compost filter media. A sprinkler system would be provided to maintain adequate moisture conditions and a bottom drain provided to direct any excess water back to the treatment

system (EQ tank). Preliminary sizing is based on a design rate of 3 ft<sup>2</sup>/cfm for an expected air flow of 100 cfm (U.S. EPA, 2003; Cornell University, 1996).

- **Control Systems.** Key elements of the control system would include the following:
  - **Flow Meters.** Primary flow meters would be installed: (1) following the EQ tank to measure inflow to the MBR unit; (2) downstream (discharge) side of the treatment system to monitor recycled water flows to the drip dispersal fields and irrigation system(s). Other flow meters would be installed within the system for internal monitoring and process control.
  - **Turbidity Meters/Controls.** A continuous turbidity meter would be installed downstream of the MBR unit. If the filter influent turbidity exceeds 0.2 NTU, an electronically actuated three-way valve prior to the disinfection process would divert the flow back through the EQ tank and MBR system for additional treatment. Otherwise, treated water would continue through the disinfection facilities and into the recycled water pump station for distribution to the either the sub-surface drip dispersal fields or irrigation system(s) on the golf course property.
  - **Telemetry.** The treatment plant (and main lift station in Woodacre) would be equipped with a telemetry control system allowing remote monitoring and control of various mechanical and electrical equipment and tank water levels. The control system would be monitored and maintained by treatment system personnel. Although the system would require daily attendance by an operator, the telemetry system would provide for continuous (24-hour) monitoring and emergency response from a remote location. The control system would provide for logging of data on system operations (e.g., flow, turbidity readings, pump operations), and would have auto-dialer/internet notification features to page the operator(s) in the event of alarm conditions.
  - **Control Building.** There would be a one-story control and operations building, approximately 600 square feet in size, to house the control and communications equipment, a small office, restroom, laboratory area, safety equipment and storage of various tools and supplies.
  - **Emergency Power.** A standby emergency generator would be provided to ensure continuous uninterrupted operation of the treatment system.

### ***Recycled Water Storage and Irrigation Use***

**Recycled Water Distribution Pump Station.** All treated water from the treatment plant will be collected and temporarily stored in an adjacent pump station for distribution for: (a) landscape, open space and/or golf course turf irrigation during the dry season; and (b) sub-surface drip dispersal during the wet season. Temporary storage will be provided in below ground tanks with capacity for a minimum of one day of peak wastewater flow. Separate pump systems will be provided for the irrigation system and drip dispersal system. The irrigation pump system will be designed with pressure tanks to provide a consistent pressurized supply to the Clubhouse Parcel for various irrigation uses. The submersible high head pumps will be used for the sub-surface drip dispersal system, sized according the drip field area and design, and provided with timer controls, high-flow override, alarm and remote operating and monitoring provisions.

**Recycled Water Irrigation.** During the dry season (typically April-October), the water from the recycling facility would be supplied for landscaping, habitat restoration, turf and open space irrigation on the Clubhouse Parcel and potentially other parts of the golf course property, which has historically relied on raw water supplies from MMWD. Recycled water would be sufficient to meet the normal irrigation needs of approximately 9 acres. There are presently approximately 12 acres of irrigated landscaping and golf course turf on the Clubhouse Parcel suitable for irrigation with recycled water (**Figure 8-5**). The recycled water would be supplied in a dedicated pressurized recycled water transmission line available for tie-in to the irrigation system(s) at the Clubhouse Parcel. The recycled water would not be connected to or mix with the potable supply to the property. Raw water from MMWD could be mixed with the recycled water to augment the irrigation system supply.

The golf course property owner/operator would have to comply with recycled water use area requirements, per Title 22 requirements outlined in **Section 5**. These cover items such as signage and markings, protection of drinking water fountains and outdoor eating areas, setbacks from wells, prevention of runoff and spray drift, and protection against cross-connection with domestic water lines.

In addition to irrigation, the treated water could potentially be used for other approved recycled water uses on the Clubhouse Parcel, which would depend on the future development of the property. A pump-out station would be provided for the potential recycled water use. Recycled water could also be made available through-out the year for use by sewer cleaning services, such as those conducting this work for nearby municipal sewer systems. Water for construction uses (e.g., dust control, soil compaction, equipment washing) could also be supplied from the recycled water pump-distribution station. Either of these off-site recycled water uses would require additional user agreements consistent with State requirements.

**Sub-surface Drip Dispersal Fields.** During the wet season or any other time irrigation uses are suspended, the recycled water would be routed to sub-surface drip dispersal fields. The proposed areas for sub-surface drip dispersal of treated water are located within an approximately 3.2-acre area within the Clubhouse Parcel in the general area of golf hole #1 and the rough are between #1 and #9 fairways; see **Figure 8-5**. These areas coincide with soils of suitable depth and permeability as indicated in the Soil Survey of Marin County, and further documented in engineering plans prepared in 2005 for proposed replacement of the golf course clubhouse onsite wastewater system.

Additional soils testing of the Clubhouse property will be required to formalize the recommended sizing, configuration and design parameters for a suitable drip dispersal system consistent with Marin County and State requirements. The drip field design would be adjusted, as needed, to accommodate future development plans for the Clubhouse Parcel.

**Recycled Water Management.** Under the recommended project, the irrigated turf and landscape areas of the golf course property would become a recycled water use area and, as such, would require various measures to comply with applicable Title 22 standards, including the following:

- The system must be operated to ensure no runoff of irrigation water from the recycled water use areas;



- No spray, mist or runoff may enter dwellings, designated outdoor eating areas, or food handling facilities;
- Drinking water fountains must be protected against contact with recycled water spray, mist or runoff;
- No irrigation with disinfected tertiary water can occur within 25 feet of a perennial (flowing) stream.
- Standard warning signs must be posted on the property alerting the public of the use of recycled water for irrigation;
- Minimum pipe separation distances (horizontal and vertical) must be maintained between recycled water lines and potable water lines, and measures taken to ensure no cross-connections between the two water systems;
- Above-ground facilities such as irrigation valves and control boxes must be labeled or tagged as part of a recycled water system; wherever possible, new piping and fittings should be purple pipe or marked with purple tape.
- Quick couplers and sprinkler heads must be of a type or secured in a manner that permits operation by authorized personnel only.

Implementation of the above measures would be the responsibility of the property owner as the designated water recycling user. Costs for implementing these measures would be borne by the property owner and not included as part of the project costs.

Off-site uses of recycled water would be managed by the County/District.

## **Recycled Water Production**

The volume of recycled water produced under average conditions is estimated to be: (1) approximately 25.6 acre-feet per year (8.3 million gallons) during the normal irrigation season of April through October; and (2) a total annual volume of 46 acre-feet (15 million gallons) for irrigation and other potential uses throughout the year. During the normal summer irrigation season the water balance-irrigation calculations indicate the optimum amount of landscape/turf irrigation area to be approximately 9 acres.

Recycled water would also be available during the winter wet season (November-March) that could be used for other uses such as construction water, sewer cleaning, and certain types of water-dependent environmental, depending on weather conditions.

## **Estimated Costs**

### ***Capital Costs***

The estimated capital costs for the recommended water recycling facilities are presented in **Table 8-4**. The bottom line in the table converts the total project costs to the average cost per connection, based on service to 360 parcels in the combined Woodacre and San Geronimo

communities. Detailed itemization of cost is provided in **Appendix H**, including quantities and unit cost assumptions. These assumptions were developed through discussions with manufacturers, equipment suppliers, and local contractors, and through review of recent contractor bids for similar work in Marin County, where applicable.

### **Annual Operation and Maintenance Costs**

The estimated annual operation and maintenance (O&M) costs for the recommended water recycling facilities are provided in **Table 8-5**, with supporting itemized calculations and assumptions are included in **Appendix H**. The O&M costs cover estimated labor, equipment, materials and other expenses required to perform the necessary inspections, water quality sampling, data analysis, report preparation, sludge disposal, and routine maintenance for the collection system and MBR treatment/recycling plant. Also included are estimates of annual energy costs (electrical) for operation of the main lift station (in Woodacre) and the treatment system. Additionally, O&M costs include an allowance for equipment repair/replacement, which would be required over the life of the system. An allowance of 10% is included as a contingency. Not included are any costs associated with the use and management of the recycled water for golf course irrigation, which would be borne by the golf course. The cost estimates were developed based on the expected operation and monitoring needs defined above, and using data and experience from monitoring and maintenance of other similar systems in Marin County and other Northern California communities. The average annual cost per property is based on an estimated 365 ESDs (equivalent single family dwellings), which includes 360 properties in the Woodacre and San Geronimo service areas, plus an allowance of 5 ESDs for the golf course clubhouse, which would be connected to the water recycling facilities.

**Table 8-2. Capital Cost Summary**

<b>Cost Item</b>	<b>Estimated Cost (\$)</b>
Collection System – Woodacre	\$4,216,575
Collection System – San Geronimo	\$1,956,800
Tertiary Treatment Plant	\$1,688,000
Recycled Water Irrigation and Drip Dispersal	\$1,022,500
Land/Easement Costs*	-
Mobilization/Demobilization	100,000
Permit Fees & Encroachment Fees	50,000
<b>Subtotal</b>	<b>\$9,033,875</b>
Contingency @ 15%	\$1,355,081
<b>Subtotal</b>	<b>\$10,388,956</b>
Engr & Environ Studies @ 15%	\$1,558,343
Construction Management @ 10%	\$1,038,896
Admin, Dist Formation, Financing @ 5%	\$519,448
<b>Total Estimated Cost</b>	<b>\$13,505,643</b>
<b>Estimated Cost Per Connection (360 parcels)</b>	<b>\$37,516</b>

\* It is assumed that the land/easement costs for locating the wastewater treatment plant, pipelines and recycled water dispersal facilities on the golf course property would be waived by the property owners in exchange for use and management of the recycled water produced by the project; preliminary economic analysis indicates this is a reasonable agreement and assumption.

**Table 8-3. Estimated Annual O&M Cost**

Category	Items	Cost (\$)
<b>District/Program Administration</b>	Insurance, legal, financial, administration	\$18,000
	RWQCB Permits	\$10,000
<b>Labor – Collection &amp; Treatment</b>	Systems Control Technician	\$14,000
	Grade III Operator (1/4 time)	\$46,800
	Grade I Operator (1/3 time)	\$57,000
	Field Technician (1/3 time)	\$62,400
	Engineering Consultation	\$15,000
	On-call Monitoring & Response Allowance	\$12,000
<b>Sludge Handling</b>	Bagging, Materials and Disposal Fees	\$4,800
<b>Sewer Lines</b>	Maintenance Cleaning	\$4,500
<b>Equipment</b>	Materials & Replacement	\$66,000
<b>Vehicle</b>	Lease and mileage	\$4,800
<b>Laboratory and Expenses</b>	Laboratory	\$24,000
	Cleaning Chemicals & Supplies	\$3,600
<b>Electrical</b>	Lift Station	\$661
	MBR Treatment Plant	\$25,730
	UV Disinfection	\$3,212
	Treated Water Distribution	\$3,212
	Misc electrical, phone, internet	\$600
<b>Sub-total</b>		\$379,613
10% Contingency		\$37,961
Estimated Total Annual Cost		\$417,575
<b>Estimated Annual Cost per Connection (365 ESDs)*</b>		<b>\$1,144</b>

\*Includes assumed 5 ESDs for Golf Course property

On a per acre-foot basis, the cost for production of recycled water is estimated to be in the range of \$3,257 to \$5,852. This is based on consideration of the specific capital and O&M costs associated with elevating the treatment level and delivering tertiary treated water for the proposed recycling uses. The range of costs account for the low (irrigation season only) and high (year-round potential) volume of recycled water produced by the project. Costs are estimated based on a 30-year operating period, using a 5% discount rate. Supporting assumptions and calculation worksheets are provided in **Appendix H**.

## Reliability of Facilities

**Table 8-4** provides an itemized summary of the reliability features that would be incorporated in the recommended water recycling facilities in compliance with specific requirements of Title 22. These include emergency storage and long-term (winter) sub-surface dispersal system, treatment system redundancies and other provisions to ensure that the system complies with all protections to public health and water quality required for approved uses of disinfected tertiary recycled water.

**Table 8-4. Water Recycling Treatment Plant Design and Reliability Features**

<b>FLEXIBILITY OF DESIGN (CCR Title 22, Article 8, § 60333)</b>
<p>Treatment plant design would provide flexibility of operation through:</p> <ol style="list-style-type: none"> <li>1. Influent equalization tank (EQ) and standby storage to regulate the flow through the treatment plant;</li> <li>2. Provisions for internal recycling of wastewater within the plant when discharge specifications are not met or for other temporary interruption of plant operations; and</li> <li>3. Providing 100% capacity sub-surface drip dispersal fields disposal of treated water throughout the wet weather season (5+ months), and supplemental or alternative method of disposal during the rest of the year.</li> </ol>
<b>ALARMS (CCR Title 22, Article 8, § 60335)</b>
<p>Alarm devices installed in the treatment system would provide warning of:</p> <ol style="list-style-type: none"> <li>1. Loss of power from the normal power supply;</li> <li>2. Failure of biological treatment (blower failure);</li> <li>3. Failure of filtration process (turbidity readings), and</li> <li>4. Failure of disinfection process (UV light sensors).</li> </ol> <p>The alarm devices would be independent of the normal power supply of the treatment plant. The plant operator, superintendent, and other parties responsible for the management of the plant would be alerted of any alarm condition. A telemetry system would be employed for remote notification to the treatment operator(s) who would be on-call 24 hours per day.</p>
<b>POWER SUPPLY (CCR Title 22, Article 8, § 60337)</b>
<p>The power supply would provide the following reliability features:</p> <ol style="list-style-type: none"> <li>1. Alarm and standby power source;</li> <li>2. Automatically actuated short-term retention provisions at the influent lift station/EQ tank, and overflow to the emergency storage tank(s) if necessary.</li> </ol>
<b>EMERGENCY STORAGE OR DISPOSAL (CCR Title 22, Article 10, § 60341)</b>
<p><b>Short-term.</b> Short-term emergency facilities would provide sufficient storage capacity at the influent flow equalization tank and supplementary emergency storage tank(s) for minimum of 24-hour storage of influent at peak flow. Standby power source (emergency generator) would be provided to assure uninterrupted operation of these units, and will also provide back-up power for the irrigation and drip dispersal pump station.</p> <p><b>Long-term.</b> Long-term disposal capacity for wastewater to be provided by sub-surface drip dispersal fields with capacity for the full daily design flow. It would be operated as the primary disposal method during the wet season, and as a supplemental or alternate method of disposal during the dry/irrigation season.</p>
<b>PRIMARY TREATMENT (CCR Title 22, Article 10, § 60343)</b>
<p>Influent EQ and short-term emergency storage would provide redundant capacity to augment primary treatment process within the MBR unit.</p>
<b>BIOLOGICAL TREATMENT (CCR Title 22, Article 10, § 60345)</b>

The biological treatment unit (MBR) would have alarm system and duplicate equipment (blowers and air diffusers) capable of producing oxidized wastewater with one unit not in operation.

**SECONDARY SEDIMENTATION (CCR Title 22, Article 10, § 60347)**

Secondary sedimentation not applicable for MBR treatment process.

**COAGULATION (CCR Title 22, Article 10, § 60349)**

Coagulation not required; the filtration system (MBR) is provided with effluent turbidimeters and automatic bypass to satisfy coagulation waiver requirements of the California Water Recycling Criteria.

**FILTRATION (CCR Title 22, Article 10, § 60351)**

Filtration processes for MBR provides:

1. Alarm;
2. Multiple (2) filter units capable of treating the entire flow with one unit not in operation;
3. Automatically actuated bypass, storage and treatment of “non-spec” water.

The MBR system is capable of achieving effluent turbidity limits established in Title 22 requirements for tertiary treatment using microfiltration.

**DISINFECTION (CCR Title 22, Article 10, § 60353)**

Reliability features provided by the disinfection system:

1. Alarm and standby UV light and/or chlorination systems;
2. Short-term retention for “non-spec” water; and
3. Long-term (5+ months) alternate disposal to sub-surface drip dispersal fields for fully treated or “non-spec” water.

## **PROJECT IMPLEMENTATION PLAN**

### **Agreement with Recycled Water User**

A legal agreement would be required between the County of Marin and the owners of the golf course property, which is anticipated to cover the following main points:

1. Long-term lease of portions of the Clubhouse Parcel for placement and operation of water recycling facilities;
2. Production and delivery of disinfected tertiary recycled water for exclusive use by the golf course property owners for irrigation uses;
3. Commitment of the golf course property owners to use and manage the recycled water and appurtenant transmission facilities in accordance with applicable State, Regional Water Board and County requirements; the owners would also have the option of contracting with the County/District for the performance of this work.

4. Provision of sewer service to replace existing septic systems at the clubhouse and maintenance yard, subject to the property owners paying an equitable annual user fee for sewer service.

The following is a preliminary outline and list of items expected to be addressed in the agreement:

- Facts and general background information (“recitals”), including statement of purpose and intent, interest and role of each party to the agreement, permit authorization for the water recycling facilities/operations, suitability and needs of the property for use of recycled water, etc.
- Definitions of terms used in the agreement, including technical, regulatory and legal
- Terms of the Agreement
  - Term/duration of the agreement
  - Description of the wastewater facilities, including map(s) and description of land area required
  - Recycled water quality and quantities
  - Applicable regulatory codes, documents and requirements
  - County/District operational responsibilities
  - Property owner operational responsibilities
  - Sewer service connection for golf course clubhouse and maintenance building and associated fees
  - Access provisions
  - Various legal provisions

## **Governance and Financing**

### ***Governance***

A public entity (District) would be required to assume responsibility for ownership and ongoing operation of any community facilities that are constructed. A public entity is also required to oversee the construction of the wastewater facility improvements, including the acquisition and management of funding for construction as well as for ongoing operation and maintenance. The public entity formed for ongoing operation and maintenance must be in place prior to initiation of project construction.

The present wastewater feasibility study and environmental studies are being conducted by the County of Marin, which has general authority for wastewater management throughout the unincorporated area of the County. Acting in this general capacity, the County has the authority to continue through the design and construction phase of the project, if this is desired.

**Appendix H** provides an overview of the potential options available along with some of the key considerations that may influence the local decision on an appropriate institutional arrangement for the community. The main options identified include: (a) creation of a new dependent district under the governing authority of the County Board of Supervisors; (b) creation of an independent district with a locally-elected board of directors; and (c) coverage/annexation under an existing independent district such as Marin Municipal Water District or Ross Valley Sanitation

District. In general, all options presented are technically viable; the ultimate decision by the community would likely focus on issues of local autonomy, economics and possibly political or personal preferences. Preliminary analysis indicates the creation of a dependent district under the County of Marin, as followed for the Marshall Community Wastewater project, as the apparent best course of action.

## ***Financing***

### *Construction Financing*

**Grant Funding.** Grant funds have been secured to pay for most of the engineering and environmental studies to date. Grant funds may also potentially be available to help finance a portion of project implementation. Such funds could potentially be used to pay for administration, planning and design-related services, and construction costs. However, it is likely that any grant funds would only be able to cover a portion of the total costs. For example, in the Marshall Phase Community Wastewater Project, grant funds covered roughly half of the overall project costs

**Assessment District.** The primary source of funding for implementation of the recommended water recycling project would be provided through the formation of a local assessment district. This is one of the most common methods used to finance sewer systems and other public works projects. The assessments would be secured against the properties in the project service area that receive benefits from the facilities. The funds raised through this process would then be used to support low-interest loans and/or the sale of bonds to pay for the balance of the construction costs not covered by grants.

### *Ongoing Operation and Maintenance Fees*

Once constructed, the project facilities would require ongoing operation and maintenance, the costs for which would be paid through the collection of fees or user charges from all properties served by the project. These fees are normally collected as part of the annual property tax bill. Estimated annual operation and maintenance costs are summarized in **Table 8-3**, indicating an annual cost of approximately \$1,144 per parcel. Further details on the estimated costs are included in **Appendix H**. As discussed below, annual O&M fees would be established by ordinance for all property owners receiving wastewater services, and would normally be updated and approved annually by the Board of Supervisors (or District Board of Directors).

## **Ordinances**

It is anticipated that project implementation would require adoption of two ordinances pertaining to the provision of wastewater service as noted below. Since the proposed project does not entertain the possibility of making recycled water available to multiple parties, an ordinance addressing the use of recycled water would not be necessary. However, an ordinance specifically for the sale and use of recycled water for off-site construction watering and sewer line cleaning would be developed if this practice is adopted as part of the facility operations. Requirements related to the use of recycled water by the golf course property owner(s) (primary recycled water “User”) would be covered in an agreement between the County/District and the golf course property owner(s).

## ***Wastewater Regulations Ordinance***

The Wastewater Regulations Ordinance would be the basic document regulating the use of the community wastewater system, including such things as installation and connection of building sewers, installation of sewer laterals, permits and procedures for installation and connections to the system, discharge of waters and wastes into the system, construction standards, prohibitions, enforcement and other administrative issues.

## ***Fee Ordinance***

The fee ordinance would cover the fees charged to property owners receiving wastewater services, and is normally updated and approved annually by the Board of Supervisors (or District Board of Directors). It would, for example, address the method of determining the fees related to the administration of the wastewater facilities, including operating, maintaining, managing, upgrading, and replacing components of the sewer system, treatment plant and water recycled operations. It would also address the method of fee collection, which is normally via the property tax bill.

## **Tentative Water Recycling Requirements of Regional Water Board**

### ***General WDR for Small Domestic Wastewater Systems - Order WQ 2014-0153-DWQ***

The recommended water recycling project would qualify for coverage and would most appropriately be regulated under the State Water Board's *General Waste Discharge Requirements for Small Domestic Wastewater Systems - Order WQ 2014-0153-DWQ* (General Order). This is a general permit applicable to small, community-type wastewater systems such as the Woodacre-San Geronimo project. Facilities with average monthly wastewater flows of 100,000 gpd or less are eligible for coverage under this General Order. The San Francisco Bay Regional Water Quality Control Board has applied Order WQ 2014-0153-DWQ to other community wastewater projects in the region, including the Marshall Community Wastewater System in Marin County.

The provisions under the General Order cover the entire wastewater system, which is defined in the Order as including "... the collection system, treatment equipment, pumping stations, treatment ponds, clarifiers, and/media filters, disinfection systems, recycled water systems (including distribution systems), storage ponds, land application areas, and other systems associated with the collection, treatment, storage, and disposal of wastewater". The Order contains requirements for various types of wastewater treatment and disposal systems, including water recycling facilities. In addition to general provisions for water quality protection, it includes performance standards, effluent limitations, and horizontal siting criteria applicable to different treatment, storage and disposal methods. The General Order provides a "Model Monitoring and Reporting Program" (Attachment C in the General Order), which sets forth the standard scope and details normally applied, with provisions for project-specific requirements assigned by the Regional Water Board as deemed necessary.

Some of the key requirements applicable to the Woodacre–San Geronimo project would include the following:



- **Title 22 Water Recycling Criteria and Engineering Report.** The project will be expected to adhere to all applicable requirements for production, storage and use of disinfected tertiary recycled water per Title 22 Water Recycling Criteria. Compliance details will be demonstrated in an Engineering Report for the water recycling facilities, subject to review and approval by the State Water Board Division of Drinking Water (DDW), per Article 7, Section 60323 of Title 22. The required Engineering Report will describe the details of the facilities and operations plan for the treatment, storage, distribution and use of recycled water, in order to document compliance with all relevant requirements of Title 22. The Engineering Report will be prepared in accordance with DDW guidelines.
- **Water Recycling System Setbacks.** **Table 8-6** lists the horizontal setback requirements applicable to the siting of various wastewater system components. The setbacks reflect a combination of requirements cited in the General Order, Title 22, State Water Well Standards, and California Plumbing Code plus locally adopted criteria in Marin County. Adjustment of setback distances may be made by the Regional Water Board and/or the DDW on a project-specific basis, also considering outcomes and recommendations from the EIR process.

**Table 8-5. Summary of Horizontal Setback Requirements (feet)**

<b>System Component</b>	<b>Domestic Well</b>	<b>Flowing Steam<sup>1</sup></b>	<b>Ephemeral Stream<sup>2</sup></b>	<b>Property Line</b>	<b>Lake or Reservoir<sup>3</sup></b>
Treatment Plant	100	100	50	5	200
Sub-surface Dispersal Fields	100	100	50	5	200
Irrigation Use Areas	50	25	50	25	200

<sup>1</sup> Year-round and seasonal (intermittent) streams

<sup>2</sup> Surface water drainage features that carry runoff during and shortly following rain events.

<sup>3</sup> Natural lakes and water supply reservoirs

- **Effluent Limitations.** Anticipated effluent limitations for the water recycling facility are listed in **Table 8-6**, based on Title 22 standards and requirements contained in the General Order for MBR treatment units. An effluent limit for total nitrogen must be considered for any wastewater system with a design flow over 20,000 gpd. The removal requirement of 50% (treated water compared to influent concentration) is the standard applicable to systems deemed to have a “low threat” of water quality impact, considering the location, site conditions, and method of dispersal or reuse. Land application for landscaping, open space and/or golf course irrigation fits the category of “low threat” due to the uptake and attenuation of nitrate by vegetation.

**Table 8-6. Proposed Effluent Limits**

Constituent	Average	Maximum
BOD (mg/L)	30 (monthly)	45 (7-day ave.)
Total Suspended Solids (mg/L)	30 (monthly)	45 (7-day ave.)
Turbidity (NTU)	0.2 <sup>1</sup>	0.5 <sup>2</sup>
Total Coliform (MPN/100 ml)	2.2 <sup>3</sup>	23 <sup>4</sup>
Total Nitrogen (mg/L)	50% Removal <sup>5</sup>	-

<sup>1</sup> Not to be exceeded more than 5% of time in 24-hr period

<sup>2</sup> Not to be exceeded at any time

<sup>3</sup> Median for seven day period

<sup>4</sup> Not to be exceeded more than once in any 30-day period

<sup>5</sup> May be calculated on an annual basis

- **Irrigation with Recycled Water.** Requirements applicable to landscape, open space and/or golf course irrigation operations include:
  - No irrigation is permitted within 24 hours of forecasted precipitation with a greater than 50-percent probability of occurring, during precipitation events, or when the irrigation area soils are saturated.
  - No irrigation is permitted when the wind speed exceeds 30 miles per hour.
  - Surface runoff of recycled water from the irrigation area is prohibited.
  - Mosquito breeding shall be mitigated by ensuring no standing water more than 48 hours after application of irrigation water.

Compliance with all requirements for limiting public exposure to recycled water as contained in Title 22 Water Recycling Criteria and the required Engineering Report.
- **Sub-surface Drip Dispersal Fields.** Requirements applicable to the sub-surface drip dispersal fields include:
  - Wastewater (in this case tertiary treated recycled water) shall not surface at any location of the disposal area.
  - No part of the disposal system shall extend to a depth where the recycled water may pollute groundwater.
  - As applicable, the pressure distribution system shall be equipped with cleanouts or a flushing system to allow solids to be removed from distribution pipes and orifices when needed.
- **Required Technical Reports.** Within 90 days following the Regional Board's issuance of coverage under the General Order, submission of the following reports will be required:

- *Spill Prevention and Emergency Response Plan* that describes operation and maintenance activities to prevent accidental releases of wastewater and to effectively respond to such releases to minimize environmental impacts.
- *Sampling and Analysis Plan (SAP)* describing the procedures that will be followed to comply with the required sampling and testing requirements of the Order.
- *Sludge Management Plan* which contains estimates of sludge volumes generated by the treatment plant and describes the equipment, processes and procedures that will be followed for collection, dewatering, drying and disposal of the sludge.

### **Statewide General WDRs for Sanitary Sewers (SWRCB Order 2006-0003-DWQ)**

In addition to the General Order WQ 2014-0153-DWQ, the project will also be required to comply with the Statewide General WDRs for Sanitary Sewers. This is a general permit pertaining to the management of sanitary sewer systems of more than one mile in length that are owned or operated by a municipality, sanitary district or other public authority. Enrollment under the General Permit must occur at least three months prior to start of operations. The Order will require the County (District) to develop and implement a written Sewer System Management Plan (SSMP), including provisions to provide proper and efficient management, operation, and maintenance of sanitary sewer systems, while taking into consideration risk management, costs and benefits. Additionally, an SSMP must contain a spill response plan that establishes standard procedures for immediate response to a sanitary sewer overflow in a manner designed to minimize water quality impacts and potential nuisance conditions. The Order also contains spill notification, monitoring and reporting requirements.

## **Permits, Right-of-Way, Design, Construction & Community Outreach**

### ***Permits***

In addition to the Waste Discharge Requirements issued by the Regional Water Board, the following is a list of the permits anticipated to be required for project implementation:

- General Construction Stormwater Permit for land disturbance of one acre or more
- General WDRs for Sanitary Sewers (SWRCB Order No. 2006-0003-DWQ)
- Streambed Alteration Agreement for pipeline creek crossings - California Department of Fish and Wildlife
- Air quality permit - Bay Area Air Quality Management District
- Encroachment permits for sewers, force mains, and lift stations within road rights-of-way; Marin County Department of Public Works (DPW)
- Grading, drainage, building and electrical permits; Marin County DPW and Building Department
- Septic tank abandonment and drip dispersal installation permits; Marin County Environmental Health Services

## ***Utilities***

Utility requirements for the project are expected to include:

- PG&E – treatment plant and pump stations
- MMWD – potable water supply to treatment building
- AT&T – telephone and internet service

## ***Facilities Design***

Design of the wastewater collection, treatment and recycling facilities is expected to include the following elements:

- Surveying
- Geotechnical investigation
- Soils, percolation and groundwater evaluations for sub-surface drip dispersal facilities
- Collection system design
- Treatment plant design
- Civil engineering -including grading, drainage, utilities, storage ponds, pumps, piping etc.
- Electrical engineering
- Design reports, plans, specifications, engineers estimate

## ***Construction Management***

Construction management would include:

- Bidding assistance
- Services during construction:
  - Requests for information, change orders, submittals, payment requests, etc
  - Construction inspection and testing
  - Daily logs and photo documentation
  - Utilities and coordination
  - As-built Drawings
- O&M Manual(s)
- Start-up Assistance

## ***Community Outreach***

Community outreach would be an on-going activity during project implementation including: (a) public meetings with the affected property owners in the service area and other interested parties; (b) executing access agreements with various property owners for design work and construction access in some cases; (c) obtaining easements, if necessary; and (d) ongoing announcements, FAQs and other communications with members of the community and neighborhood steering committee(s).

## ***Projected Schedule***

Year 1: It is anticipated that in the next year and a half, the new or continued use of the golf course property will be determined. At that point, the following steps would be initiated sequentially.

Year 2: The CEQA review for the apparent best alternative will recommence. This should take approximately one year from scoping session to ratification by the Marin County Board of Supervisors.

Year 3: Formation of District; initiate agreements with golf course property owners; identify and secure funding sources to supplement local assessments.

Year 4: Design the system, prepare Engineer's Report and conduct Assessment Proceedings.

Year 4: Apply for State permits.

Year 5: Prepare final bid package, issues Request for Proposals, and select construction contractor(s) – 6 months.

Year 6: Construction – 18 months.

## **OPERATIONAL PLAN**

The following summarizes the operational plan for the recommended wastewater collection, treatment and water recycling facilities, including responsible parties, operation and maintenance activities, and monitoring and reporting requirements.

### **Responsible Parties**

#### ***County***

The County/District would be the owner and responsible party for operation and maintenance of the wastewater collection facilities, recycled water treatment plant, and recycled water transmission lines.

It is anticipated that the operations would be performed by a qualified and properly certified wastewater facilities contractor. The contractor would be required to be a California certified wastewater treatment plant operator Grade III, minimum. Preliminary estimates of staffing for contract O&M services include:

- Chief Operator, Grade III
- Grade I Operator
- Field Technician
- Systems Control Technician

The County/District would also retain the services of an engineering consultant for oversight of operations, engineering analysis and other technical assistance as needed. The County may also establish a contractual arrangement with Marin Municipal Water District for additional support services, such as laboratory analytical work, emergency response, or other technical assistance.

#### ***San Geronimo Golf Course Property Owner***

The San Geronimo Golf Course property owner would be the primary Recycled Water User. They would be responsible for maintenance and operation of the irrigation distribution system

and the recycled water uses areas (i.e., the landscaping, habitat restoration, open space or golf course turf areas). They would carry-out their responsibilities in accordance with the terms of an operating/lease agreement with the County/District and in accordance with all State and Regional Water Board requirements for use of recycled water.

The property owner will designate a Use Area Supervisor, who would be the person having responsible charge for: (a) operation and maintenance of recycled water irrigation facilities within the use areas on the property; (b) prevention of potential hazards; (c) implementing and complying with applicable permit conditions and best management practices for use of recycled water on the golf course property; (d) coordination with any cross-connection control programs for the property, as applicable; (e) control of onsite piping to prevent any cross connections with potable water supplies; and (f) day-to-day communications and coordination with the County/District water recycling facility operators.

## **Operation and Maintenance**

Operation and maintenance (O&M) guidelines will be provided in an O&M Manual covering the wastewater collection, treatment and recycling facilities. This document will incorporate the WDRs and Monitoring and Reporting Program (MRP) requirements issued by the RWQCB along with specific operation and maintenance instructions for all system components and equipment at the time of project facilities construction. A summary of anticipated operation and maintenance activities is presented below.

### ***Wastewater Collection System***

#### ***Gravity Sewers***

Operation and maintenance activities for a conventional gravity sewer system consist of cleaning the sewers, monitoring sewers for illegal inflow connections, and pump station operation and maintenance. Access for cleaning is provided by manholes (6-inch and 8-inch gravity sewers) and by clean-outs (for 4-inch laterals). Cleaning of gravity sewers may require removal of obstructions from time to time, as well as flushing. Video inspection of sewer lines would typically be performed from time-to-time as a preventative measure and/or to investigate specific sections of sewer lines.

Main pump station O&M would involve routine onsite inspections (e.g., weekly) to observe pump station operations and conditions, as well as on-going monitoring of operations remotely via telemetry. Major inspections and servicing would be conducted quarterly or as needed, including evaluation and servicing of all major pumping components, valves, piping, controls, alarms, structural elements and other mechanical/electrical equipment. The emergency generator would be tested and operated during these quarterly inspections. Repair and/or replacement of equipment components would be performed, as needed. Operator(s) would be tasked with the responsibility to respond to alarms or other emergency conditions typically within 2 to 4 hours.

#### ***Pressure Sewers***

On-lot grinder pumps require periodic maintenance and cleaning, which are normally handled by the sewer district; the associated electrical energy costs are absorbed directly by the property owner. Annual inspection of all grinder pumps is recommended. High-pressure flushing of the pressure sewer lines may be required every few years to scour slime and solids buildup. A full walk-through inspection of the pressure sewer alignments is recommended

yearly, accessing all valve boxes, exercising valves, and other visual inspections. Visual inspection of pressure lines at creek crossings is recommended to be done at least quarterly.

### ***Treatment System***

System maintenance would include regular inspection of all equipment and processes. A telemetry system would be incorporated to facilitate remote, continuous monitoring of the critical elements of the pump stations and the treatment system. Ongoing inspection and maintenance of the wastewater treatment facility and collection system is anticipated to include on-site physical work several days a week.

### ***Sub-surface Drip Dispersal System***

During the period of use (i.e., wet season months) drip dispersal system operation would entail the following:

- Monthly inspection of each drip field area, including surface conditions, valve boxes, and measurement of water level in monitoring wells;
- Inspect and service subsurface drip dispersal systems per manufacturer's recommendations, including supply lines, air relief valves, filters and flush return lines.
- Repair/replace drip field components (e.g., valves, utility boxes, risers), as needed.

### ***Landscape Irrigation with Recycled Water***

Operations would primarily consist of visual observations of irrigation use areas, noting and correcting any evidence of ponding or runoff of irrigation water, and other abnormal conditions. Additionally, permit requirements will dictate adherence to the following minimum irrigation practices for use of recycled water:

- Avoid wastewater spraying with 24 hours of forecasted rainfall with greater than 50% probability of occurring, during rainfall event, or if surface soil is saturated;
- Avoid wastewater spraying when wind speeds exceed 30 miles per hour; and
- Limit irrigation to avoid ponding, soil saturation or creation of runoff.

**Table 8-9** provides a summary listing of management and operation requirements regarding golf course irrigation that would be incorporated in the recycled water use agreement between the property owner(s) and the County/District.

**Table 8-7. Management and Operation Requirements for Landscape Water Recycling**

- *Designate a Use Area Supervisor, who shall be the person designated by the Golf Course property owner(s) to have responsible charge for: (a) operation and maintenance of recycled water irrigation facilities within the property use area(s); (b) prevention of potential hazards; (c) implementing and complying with applicable permit conditions and best management practices for use of recycled water on the property; (d) coordination with any cross-connection control programs for the property facilities, as applicable; (e) control of onsite piping to prevent any cross connections with potable water supplies; and (f) day-to-day communications and coordination with the County/District Water Recycling Facility operators.*
- *Comply with use area conditions per Title 22, WDRs and project-specific BMPs.*
- *Maintain a copy of use area requirements, BMPs and other relevant documents for use by property maintenance personnel and for inspection by County, Regional Water Board and DDW staff.*
- *Submit onsite observation reports and use data to the County/District for inclusion in required reports to the Regional Water Board and DDW.*
- *Ensure that property maintenance personnel receive training to assure proper operation of recycling equipment, worker protection, and compliance with applicable requirements.*
- *Maintain in good working order and operate as efficiently as possible any facility or control system to achieve compliance with applicable requirements for use of recycled water.*
- *Implement and adhere to the following general management practices for use of recycled water for landscape irrigation:*
  - a) *application of recycled water at reasonable agronomic rates considering soil, climate, and nutrient demand;*
  - b) *management of recycled water to prevent nuisance conditions or breeding of mosquitoes;*
  - c) *conduct irrigation during periods lowest public use, with consideration to allow maximum drying time prior to subsequent public use;*
  - d) *perform required inspections, reporting and regular maintenance of areas irrigated with recycled water;*
  - e) *manage operations to minimize worker contact with recycled water.*
- *Implement other best management practices as specifically adopted for the facility, including measures identified in the Title 22 Engineering Report, Waste Discharge Requirements, Environmental Impact Report mitigation measures, or, as applicable, BMPs identified in State Water Board Order No. 2009-0006-DWQ – General Permit for Landscape Irrigation Uses of Municipal Recycled Water: [http://www.waterboards.ca.gov/water\\_issues/programs/water\\_recycling\\_policy/docs/wqo\\_2009\\_0006\\_general\\_permit.pdf](http://www.waterboards.ca.gov/water_issues/programs/water_recycling_policy/docs/wqo_2009_0006_general_permit.pdf)*



## Monitoring and Reporting

The wastewater system will be monitored to verify compliance with performance objectives and to ensure safe and proper operation of the collection, treatment, storage, disposal and irrigation facilities. Specific monitoring requirements will be established as permit conditions by the Regional Water Board in the MRP. They are anticipated to include the following.

### ***Wastewater Flow***

Wastewater flows will be monitored at the treatment plant at two primary locations: (1) influent EQ tank; and (2) recycled water discharge line (to the dispersal/irrigation pump station). Flows will be monitored to determine the total daily flow into the system, as well as the distribution of flow to the drip dispersal/irrigation systems. Flows will be measured using in-line flow meters and/or pump event counts, dose volume and pump run-time data. Flow monitoring will also be conducted at the drip dispersal/irrigation pump station to measure and record the volume of recycled water discharged to the sub-surface drip dispersal fields and to the landscape irrigation system.

### ***Wastewater Influent and Effluent Sampling***

Wastewater effluent will be sampled routinely to monitor and assess the performance of various components of the treatment system and to verify conformance with performance requirements (e.g., effluent limits). Wastewater effluent will be sampled at the storage/dosing tanks prior to discharge to the irrigation and drip dispersal fields, and in accordance with requirements established by the Regional Water Board. Recommendations for sampling parameters and frequency are listed in **Table 8-8**. Analyses may be made from time to time for other parameters as diagnostic tools to assist in system operations and maintenance. A critical task will be daily sampling and analysis for coliform bacteria per Title 22 water recycling requirements. Contract arrangements with MMWD for coliform testing at their San Geronimo Water Treatment Plant would be an efficient way to meet this critical operating requirement. Sampling and analysis of recycled water for "Priority Pollutants"<sup>4</sup> would be required once every five years.

---

<sup>4</sup> Priority Pollutants refer to a list of 126 specific pollutants that includes heavy metals and specific organic chemicals, The list can be found in Code of Federal Regulations at 40 CFR 401.15.

**Table 8-8. Recommended Monitoring Schedule**

Wastewater Parameter	Measurement Units	Anticipated Frequency	
		Influent	Effluent
Flow	gallons per day	Daily	Daily
BOD	mg/L	Monthly	Monthly
Total Suspended Solids (TSS)	mg/L	Monthly	Monthly
Turbidity	NTU	N/A	Continuous
Total Coliform	MPN/100 mL	N/A	Daily
Total Kjeldahl Nitrogen (TKN)	mg/L	Monthly	Monthly
Nitrate-Nitrogen	mg/L	Monthly	Monthly
Priority Pollutants		-	Every 5 years

***Sub-surface Drip Dispersal Fields***

Monitoring of the drip dispersal fields shall include inspections and observations of the following:

- Daily and monthly wastewater flows;
- Pump controllers and automatic distribution valves to confirm proper operation per manufacturer;
- Groundwater levels and evidence of soil saturation or surface ponding in disposal areas;
- Evidence of burrowing animals damaging to drip lines or appurtenances;
- Soil erosion, vegetation (e.g., root) problems, or other disturbance affecting the drip field.

***Landscape Irrigation***

Monitoring of the recycled water discharge to the landscape irrigation system is anticipated to include the following items during periods when irrigation water is applied:

- Recycled water applied for irrigation (metered, monthly)
- Acreage irrigated (calculated, monthly)
- Local rainfall amounts (from weather station, monthly)
- Application rate (calculated, gal/acre/month)
- Landscape irrigation area observations for soil erosion, containment of applied water, soil saturation/ponding, nuisance odors or vectors, off-site discharge of applied wastewater (monthly during recycled water use period)

***Surface Water and Groundwater Monitoring***

Surface water and groundwater monitoring requirements may be established by the Regional Water Board as permit conditions for the water recycling facilities. Specific monitoring recommendations (constituents, locations, frequency) should be developed following the

completion of and utilizing information from the environmental review of the project. Preliminary recommendations for consideration include:

- **Surface Water Monitoring.** Establish surface water monitoring locations (“upstream” and “downstream”) on the year-round (flowing) streams that lie within 100 feet of the landscape irrigation areas, and conduct monthly sampling during the portion of the irrigation season when recycled water is applied.
- **Groundwater Monitoring.** Install a series of monitoring wells around the drip dispersal field(s), including at least one or two up-gradient control wells, and several wells on the down-gradient side of the dispersal areas. Details of the monitoring locations, parameters, and frequency would be determined in consultation with the Regional Water Board staff.

## ***Reporting***

Routine reporting of monitoring results will be required for the facility in accordance with a schedule included as a condition of the WDRs and Monitoring and Reporting Program issued by the Regional Water Board. Quarterly and Annual monitoring reporting is anticipated.

### *Quarterly Monitoring Reports*

Quarterly reports are due on the first day of the second month after the quarter ends and will ordinarily include:

- Results of all required monitoring.
- Comparison of monitoring data to the discharge specifications, applicable effluent limits, Title 22 requirements, and disclosure of any violations along with an explanation of any violation of those requirements.
- If requested by staff, copies of laboratory analytical report(s) and chain of custody form(s).

### *Annual Report*

Annual Reports are due by March 1<sup>st</sup> of the following monitoring year and will ordinarily include:

- Tabular and graphical summaries of all monitoring data collected during the year, with a section devoted specifically to recycled water monitoring and compliance per Title 22.
- Evaluation and discussion of the performance of the wastewater treatment facility and recycling operations, including capacity issues, nuisance conditions, problems, and forecast of any anticipated changes in the next year.
- Description of ultraviolet light disinfection system maintenance activities performed, addressing inspections performed, lamp bulb replacement, lamp sleeve cleaning, and manufacturer recommended maintenance activities.

- Discussion of compliance and the corrective action taken, as well as any planned or proposed actions needed to bring the discharge into compliance with requirements.
- Discussion of any data gaps and potential deficiencies/redundancies in the monitoring system or reporting program.
- Name and contact information for the wastewater operator responsible for operation, maintenance, and system monitoring.
- If required, groundwater monitoring report prepared by a California licensed professional containing an analysis of groundwater data collected during the year and a general evaluation of any impacts the wastewater discharge is having on groundwater quality.

## SECTION 9: REFERENCES

- California Division of Mines and Geology. 1976. Geology of the San Geronimo Valley Area, Marin County, California. Geology for Planning in Central and Southeastern Marin County, California. OFR 76-2 S.F., Plate 1A. San Geronimo, Geology.
- California Division of Mines and Geology. 1976. Interpretation of Relative Stability of Slopes the San Geronimo Valley Area, Marin County, California. Geology for Planning in Central and Southeastern Marin County, California. OFR 76-2 S.F., Plate 2A. San Geronimo, Slope Stability.
- California Regional Water Quality Control Board, San Francisco Bay Region. July 8, 2005. Pathogens in Tomales Bay Watershed - Total Maximum Daily Load (TMDL). Proposed Basin Plan Amendment and Staff Report.
- Cornell Waste Management Institute. 1996. Odor Treatment – Biofiltration. Cornell University Ithaca, NY <http://compost.css.cornell.edu/odors/odortreat.html>
- Crites, R. and G. Tchobanoglous. 1998. Small and Decentralized Wastewater Management Systems. WCB/McGraw Hill.
- Marin County Environmental Health Services. File review of available septic system permit information for parcels in study area.
- Marin County Environmental Health. 2017. Sewage Disposal Regulations <http://www.marincounty.org/depts/cd/divisions/environmental-health-services/septic-systems>
- Orengo Systems, Inc. 2016. AdvanTex® AX100 Treatment Systems. Rev. 2.3 [http://www.orengo.com/systems/advantex\\_wastewater\\_treatment.cfm](http://www.orengo.com/systems/advantex_wastewater_treatment.cfm)
- State Water Resources Control Board. June 2009. Order No. 2009-0006-DWQ. General Waste Discharge Requirements for Landscape Irrigation Uses of Municipal Recycled Water [http://www.waterboards.ca.gov/water\\_issues/programs/water\\_recycling\\_policy/docs/wqo\\_2009\\_0006\\_general\\_permit.pdf](http://www.waterboards.ca.gov/water_issues/programs/water_recycling_policy/docs/wqo_2009_0006_general_permit.pdf)
- State Water Resources Control Board. 2014. Order WQ 2014-0090-DWQ. General Waste Discharge Requirements for Recycled Water Use [http://www.waterboards.ca.gov/board\\_decisions/adopted\\_orders/water\\_quality/2014/wqo2014\\_0090\\_dwq\\_revised.pdf](http://www.waterboards.ca.gov/board_decisions/adopted_orders/water_quality/2014/wqo2014_0090_dwq_revised.pdf)
- State Water Resources Control Board. 2014. Order WQ 2014-0153-DWQ. General Waste Discharge Requirements for Small Domestic Wastewater Treatment Systems [http://www.waterboards.ca.gov/board\\_decisions/adopted\\_orders/water\\_quality/2014/wqo2014\\_0153\\_dwq.pdf](http://www.waterboards.ca.gov/board_decisions/adopted_orders/water_quality/2014/wqo2014_0153_dwq.pdf)
- U.S. Department of Agriculture - Soil Conservation Service. March 1985. Soil Survey of Marin County, California.
- U.S. Environmental Protection Agency. 2002. Onsite Wastewater Treatment Systems Manual

U.S. Environmental Protection Agency. 2003. Using Bioreactors to Control Air Pollution. EPA-456/R-03-003 <https://www3.epa.gov/ttnecat1/dir1/fbiorect.pdf>

U.S. Environmental Protection Agency. September 2007. Wastewater Management Fact Sheet – Membrane Bioreactors

U.S. Department of the Interior - US Geological Survey. 2000. USGS geological map and map database of parts of Marin, San Francisco, Alameda, Contra Costa, and Sonoma County, California

## Appendix A

---

# Onsite Wastewater Treatment Literature

- AdvanTex Packed Bed Filter
- UV Disinfection
- Geoflow Drip Dispersal

**AdvanTex**® Treatment Systems

# AX-RT

Manufactured by **Orenco Systems**®, Inc.



*A number of vacation homes along beautiful Smith Mountain Lake in Virginia treat their wastewater – and protect the lake – with AdvanTex® AX-RT Treatment Systems.*

## Dependable, Affordable Treatment For Residential & Small Commercial Wastewater

**Orenco Systems**®, Inc.

814 Airway Avenue, Sutherlin, Oregon, USA 97479  
Toll-Free: 800-348-9843 • +1-541-459-4449 • [www.orenco.com](http://www.orenco.com)

### Applications:

- 1-6 bedroom homes
- Small commercial properties
- New construction, repairs
- Tight lots, other site constraints
- Poor soils, shallow bury
- Stringent permit requirements
- Nitrogen reduction, disinfection
- Surface discharge



# AdvanTex® - AX-RT Treatment System

## Dependable, Affordable Wastewater Treatment, Anywhere!

The AdvanTex® AX-RT Wastewater Treatment System is the latest residential (and small commercial) treatment system in Orenco's AdvanTex line.

AdvanTex systems consistently produce clear, odorless effluent ... effluent that meets the most stringent permit limits and is ideal for subsurface irrigation and other water-saving uses. That's one reason why AdvanTex won the Water Environment Federation's "2011 Innovative Technology Award." It also won for its low power costs and low operating & maintenance costs. Plus AdvanTex is easy to install, too. Here's why:

### Pre-Plumbed Treatment System Saves On Excavation, Installation, O&M

The AX-RT is a compact "plug and play" wastewater treatment system. It can be shallowly buried and installed right behind a septic tank, as easily as a septic tank, so contractors can schedule more jobs in a single day.

The AX-RT unit includes the following functional areas of the treatment process:

1. Textile media for advanced treatment
2. Recirculation/blending chamber
3. Gravity or pump discharge to final dispersal
4. Optional Orenco UV unit when disinfection is required

This simple design fits on the smallest lots and reduces costs for excavation, installation, and O&M. That means property owners can buy AdvanTex quality at a competitive price.



*Since 2003, 116 AdvanTex Treatment Systems have been installed in Sunset Bay, a lakefront subdivision in northeast Tennessee, and 23 have been AX-RTs. According to Arthur Helms, Helms Construction, the RT's are "a lot easier to install. This one only has a few connections, so you can't hardly screw it up." Even better, Helms says that the RT "saves about 8 hours labor and saves on fittings ... I make more money with the RT. I can do it and go on to the next one."*

### Components

- |   |  |
|---|--|
| 1. Biotube® effluent filter                                     | 8. Tank baffle                               |
| 2. Inlet  | 9. Recirc return valve                       |
| 3. Treatment tank – recirc/blend chamber                        | 10. Treatment tank – recirc/filtrate chamber |
| 4. Recirc transfer line   | 11. Outlet                                   |
| 5. Recirc pumping system (discharge pumping system not visible) | 12. Splice box                               |
| 6. Manifold and spin nozzles                                    | 13. Passive air vent                         |
| 7. Textile treatment media                                      | 14. Control panel (not shown)                |

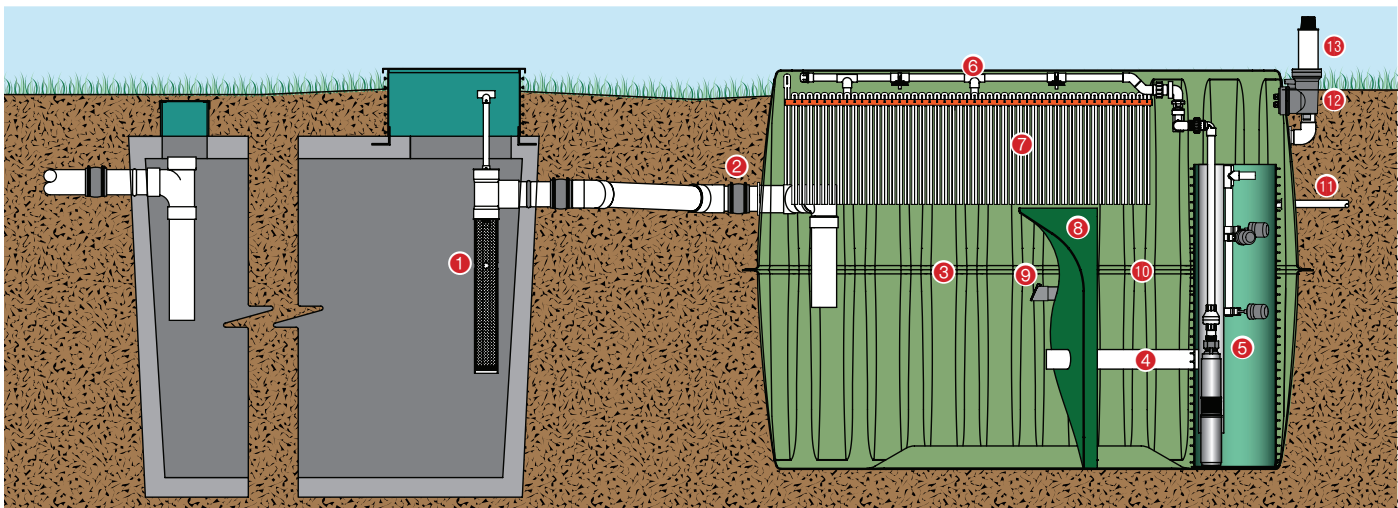

The AX-RT is a completely prepackaged "plug & play" wastewater treatment system that can be quickly installed right behind an existing (or new) watertight septic tank. The AX-RT serves 1-6 bedroom homes.

# AdvanTex® - AX-RT Treatment System

## Low Power Costs, Low Maintenance Costs

No blowers. No odors. The AX-RT is passively vented and uses only \$2-\$3 per month in electricity.<sup>1</sup> Other products can use anywhere from ten to twenty times more! AX-RT customers also have low lifetime costs. The AX-RT is easily maintainable with an annual service call, thanks to its accessible, cleanable filters and media. And the AX-RT's high-quality, high-head pumps last 20 years or more!

*Homeowner Nancy Smith was the first person to receive a \$400 cash incentive from Energy Trust of Oregon for buying an energy-efficient wastewater system: an AX-RT. Smith's drainfield failed the day before Thanksgiving and she immediately started researching replacement systems. "My determining factor was the electric use," said Smith. "Incomes are going down, expenses are going up ... I have to know going forward what things are going to cost." Smith chose the AX-RT because the annual cost for electricity runs less than \$40; other systems can run as high as \$500 or more.*

## Consistent, Reliable Performance

Stringent testing programs consistently show that AdvanTex Treatment Systems produce effluent with BOD<sub>5</sub>/TSS at or below 10 mg/L and nitrogen reduction of 60-70+%. In fact, the Maryland Department of the Environment has rated AdvanTex as tops among all "Best Available Technologies" for nitrogen-reduction.<sup>2</sup>



<sup>1</sup> Assumes electricity costs of \$0.10 per kWh and 3-4 occupants

<sup>2</sup> [http://www.state.md.us/programs/Water/BayRestorationFund/OnsiteDisposalSystems/Pages/Water/cbwrf/osds/brf\\_at.aspx](http://www.state.md.us/programs/Water/BayRestorationFund/OnsiteDisposalSystems/Pages/Water/cbwrf/osds/brf_at.aspx)

## The AdvanTex Advantage:

- Reliable, reputable
- Clear, re-usable effluent
- No noise or odors
- Complete "plug & play" package
- Easy to install and maintain
- Energy efficient
- Competitively priced
- For 1-6 bedroom homes

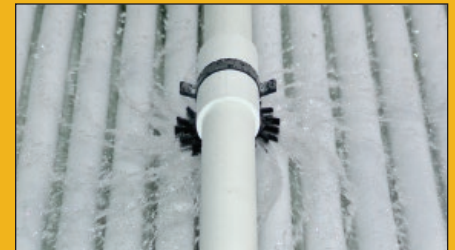

### Textile Treatment Media

Spin nozzles microdose wastewater effluent onto highly absorbent textile filters at regular intervals, optimizing treatment.



### Ultraviolet Disinfection

Our optional UV unit reduces bacteria by 99.999%, allowing wastewater re-use for irrigation, toilet flushing, etc. It uses no chemicals and has no moving parts. The UV unit is protected in its own chamber inside the AX-RT and just needs a lamp replacement every other year.



### Smart Controls

The AX-RT comes standard with Orenco's Veri-Comm™ remote telemetry control panel and monitoring system. That means service providers can oversee the system, from office or home. (Non-telemetry "smart" controls also available.)

# AdvanTex® - AX-RT Treatment System

## Carefully Engineered by Orenco

Orenco Systems has been researching, designing, manufacturing, and selling leading-edge products for decentralized wastewater treatment systems since 1981. The company has grown to become an industry leader, with about 300 employees and more than 300 points of distribution in North America, Australasia, Europe, Africa, and Southwest Asia. Our systems have been installed in about 70 countries around the world.



AdvanTex® Treatment System AXN Models meet the requirements of NSF-ANSI Standard 40 for Class I Systems.



Powered by **Franklin Electric**

# Orenco®

Orenco Systems®, Incorporated

814 Airway Avenue  
Sutherlin, OR 97479 USA  
T: 800-348-9843  
T: 541-459-4449  
F: 541-459-2884

[www.orenco.com](http://www.orenco.com)  
[www.orenco.com/sales/choose\\_a\\_system/](http://www.orenco.com/sales/choose_a_system/)

ABR-ATX-AXRT-1  
Rev. 1.3, © 04/15  
Orenco Systems®, Inc.

## Use the AX-RT for Applications Like These ...

### Small Lots

In 2011, Mike Madson, a septic system installer in Oregon, replaced a failing system along the beautiful North Umpqua River with an AX-RT. "That particular situation was really, really confining," says Madson. "There was a high bank to the river about 25 feet away and roots everywhere; we had to get things in there in compact fashion. We even had to add a drainfield to the site; the old one was bootlegged in, cedar trees had grown into it, and the leach line was plugged up." The AX-RT incorporates the recirc and discharge processes right within the RT unit, so its smaller footprint made this installation possible.



### Nitrogen Reduction

Bob Johnson of Atlantic Solutions has sold (and services) more than 325 AX-RTs, mostly in Maryland, for the state's aggressive nutrient-reduction program. Maryland requires Total Nitrogen of less than 20 mg/L to protect the Chesapeake Bay. After a year of testing 12 RTs under Maryland's BAT (Best Available Technologies) Program, Johnson reports that TN averaged just 14.6 mg/L, while BOD<sub>5</sub>/TSS averaged <5 mg/L. Says Johnson, "When you look at life cycle costs and percent of nitrogen reduction, the AX-RT costs less than other technologies for every pound of nitrogen removed."



### Strict Permit Limits, Including Surface Discharge

Kevin Davidson, an engineer with Agri-Waste Technology, designed the first AX-RT in North Carolina to replace a failing system under North Carolina's "Surface Discharge" permit. According to Davidson, the property had poor soil conditions, plus there was no room for a new drainfield. The state allowed the AX-RT for surface discharge because it produces such outstanding effluent that it could meet the required permit limits. And, with UV disinfection, it could meet the limit for fecals, too. Consequently, treated and disinfected effluent could then be discharged to a ditch.



Photo courtesy of Kevin Davidson

Davidson was able to use the existing septic tank, and the RT's configuration eliminated the need for a discharge tank, separate UV basin, and several risers and lids, reducing costs. On the O&M side, he appreciates having the UV sensors integrated into the control panel, especially the one that allows the service provider to know the bulb is working, without having to pull it out. Says Davidson, "I think the RT is the best unit, when you look at aesthetics, installation cost, ability to treat waste, and support from Orenco. Compared to other technologies, I would grade Orenco at the top."

Distributed by:

# AdvanTex<sup>®</sup> AX100 Treatment Systems

For Onsite Treatment of Commercial and Multi-Family Wastewater



Ideal for:

- Multi-family residential properties
- Cluster systems, community systems
- Subdivisions, resorts, golf course developments
- Mobile and manufactured home communities
- Parks, RV parks, rest areas
- Truck stops, restaurants, casinos
- Schools, office buildings



**Orenco Systems<sup>®</sup>**  
Incorporated

*Changing the Way the  
World Does Wastewater<sup>®</sup>*

**800-348-9843**  
**orencos.com**

# We've Written the Blueprint for the Decade

## The Product

Orenco's AdvanTex® Treatment Systems utilizing the commercial-sized AX100 can make raw wastewater up to 98% cleaner, meeting stringent regulatory requirements. It can also reduce nitrogen significantly, depending on influent and configuration. And the AX100 offers all the benefits of Orenco's residential-sized AdvanTex Treatment Systems:

- Consistent, reliable treatment, even under peak flows
- Compact package, small footprint, for small sites
- Premanufactured package, including textile medium, for quality control
- Low maintenance requirements; low life-cycle costs
- Production of clear, odorless effluent that's ideal for reuse

## The Program

It takes more than a product, however, to solve onsite wastewater problems. It takes a comprehensive program ... one that ensures a successful project every time and provides support for the life of the system. That's what Orenco Systems® has done. We've engineered a program, not just a product.

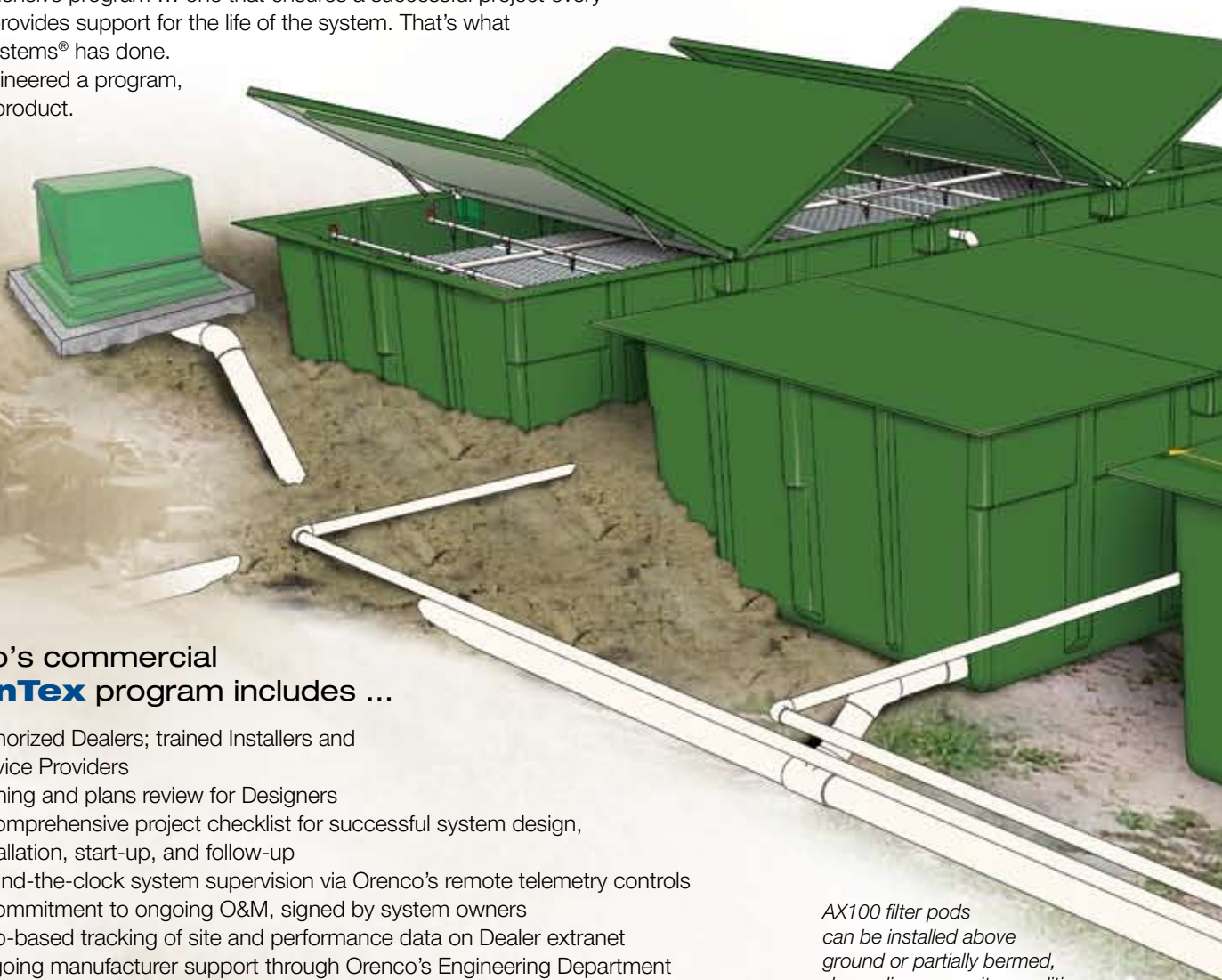

### Orenco's commercial AdvanTex program includes ...

- Authorized Dealers; trained Installers and Service Providers
- Training and plans review for Designers
- A comprehensive project checklist for successful system design, installation, start-up, and follow-up
- Round-the-clock system supervision via Orenco's remote telemetry controls
- A commitment to ongoing O&M, signed by system owners
- Web-based tracking of site and performance data on Dealer extranet
- Ongoing manufacturer support through Orenco's Engineering Department

*AX100 filter pods can be installed above ground or partially bermed, depending upon site conditions.*

# Centralized Wastewater Treatment Industry

## Decades of Research, Thousands of Installations

Orenco's patented\* AdvanTex Treatment System is a recirculating filter that's configured like a recirculating sand filter — a packed bed filter technology that Orenco engineers have helped to perfect since the 1970s. Like recirculating sand filters, AdvanTex is reliable and low-maintenance. It is superior to other packed bed filters, however, in its serviceability and longevity.

It is also superior in its treatment media. AdvanTex uses a highly efficient, lightweight textile that has a large surface area, lots of void space, and a high degree of water-holding capacity. Consequently, AdvanTex Treatment Systems can provide treatment equivalent to that of sand filters at loading rates as high as 25-50 gpd/ft<sup>2</sup> (1000-2000 L/d/m<sup>2</sup>). That means AdvanTex can treat high volume commercial and multi-family flows in a very compact space.

Our textile-based, multi-pass treatment technology has undergone third-party testing and evaluation to ANSI Standards. About 20,000 residential-sized AdvanTex filters have been installed since 2000. And more than 2,500 commercial-sized AX100 units are now in operation, including the installations described on the back page.



### Textile Media

The treatment medium is a uniform, engineered textile, which is easily serviceable and allows loading rates as high as 50 gpd/ft<sup>2</sup> (2000 L/d/m<sup>2</sup>).



### Spray Nozzles

Efficient distribution is accomplished via specially-designed spray nozzles.



### Laterals and Lids

Isolation valves, flushing valves, and hinged lids with gas springs allow easy access and servicing by a single operator.



### Telemetry Controls

Orenco's telemetry-enabled control panels use a dedicated phone line and ensure round-the-clock system supervision and real-time, remote control.

# AdvanTex® AX100 Treatment Systems

## Carefully Engineered by Orenco

Orenco Systems has been researching, designing, manufacturing, and selling leading-edge products for small-scale wastewater treatment systems since 1981. The company has grown to become an industry leader, with about 250 employees and 150 distributors and dealers representing most of the United States, Canada, Mexico, Australia, New Zealand, and parts of Europe. Our systems have been installed in more than 60 countries around the world.

Orenco maintains an environmental lab and employs dozens of civil, electrical, mechanical, and manufacturing engineers, as well as wastewater treatment operators. Orenco's systems are based on sound scientific principles of chemistry, biology, mechanical structure, and hydraulics. As a result, our research appears in numerous publications and our engineers are regularly asked to give workshops and offer trainings.



**Orenco Systems®**  
Incorporated

*Changing the Way the  
World Does Wastewater®*

**814 Airway Avenue  
Sutherlin, OR 97479**

**T • 541-459-4449  
800-348-9843**

**F • 541-459-2884**

**www.orenco.com**

**ABR-ATX-AX100-1  
Rev. 1.6, © 09/10  
Orenco Systems®, Inc.**



## Oregon Riverside Community

Since 2003, twelve AX100s have been providing advanced secondary wastewater treatment in Hebo, Oregon, for a small community collection system that discharges directly into Three Rivers, after UV disinfection. The average annual design flow is 17,000 gpd (64,400 L/d) with a peak daily design flow of 80,000 gpd (303,000 L/d) to account for I&I contributions from the collection system. Effluent BOD<sub>5</sub> and TSS are averaging 4.4 and 4.5 mg/L, respectively.



## Malibu, California Restaurant

Ten AX100s at the top of a Malibu bluff are treating high-strength waste from a large (200+ seat) beachfront restaurant, 100 feet (30 m) below. This high-visibility tourist destination requires reliable, odor-free operation. Effluent sampling indicates excellent treatment, including nitrogen reduction. At an adjacent residential community, another system, consisting of 20 AX100s capable of treating up to 60,000 gpd (227,000 L/d) peak flows, has also been installed.

## Mobile, Alabama Utility-Managed Subdivisions

South Alabama Utilities (SAU) in Mobile County, Alabama, has become the subject of nationwide classes, presentations, and tours because of its ambitious and innovative solution for serving nearly 4,000 new customers in 47 new subdivisions (as well as a number of new schools and commercial properties) northwest of Mobile. How? By installing more than 60 miles (96.5 km) of interconnected Orenco Effluent Sewers that are followed by 141 AdvanTex AX100s to treat nearly half a million gpd (1.9 million L/d) of effluent, at better than 10 mg/L.



*Champion Hills is one of the many subdivisions in rural Mobile County served by Orenco's effluent sewers and treatment systems.*

Under SAU's program, developers, builders, homeowners, and the utility all share the cost of extending wastewater infrastructure. Overall costs vary by development, but SAU currently charges each homeowner about \$2,000 to provide and install the on-lot equipment. Overall costs are about half the cost of conventional sewers.

*To order a complete design/engineering package for Orenco's Commercial AdvanTex Treatment Systems, contact your local Commercial AdvanTex Dealer. To find a Commercial Dealer, go to [www.orenco.com/systems](http://www.orenco.com/systems) and click on "Locate a Dealer." Or call 800-348-9843 and ask for Systems Engineering.*

# Orenco® UV and AXUV Disinfection Units

## Applications

The Orenco® UV and AXUV Disinfection Units provide UV disinfection in residential applications after advanced secondary treatment (10 mg/L cBOD<sub>5</sub>/TSS), when disinfection is required before dispersal. Treated effluent flows by gravity through the contact chamber and around the UV lamp where it is disinfected in a 360-degree contact zone.

Orenco UV units dramatically reduce bacteria and viruses. In side-by-side NSF® testing, they reduced bacteria by 99.999% (5 logs), meeting or exceeding the performance of other residential UV disinfection units.

Both the Orenco UV and AXUV Disinfection Units require installation inside a pump or gravity discharge basin or in a separate tank following advanced secondary treatment. Both are gravity-flow units.

The AXUV is specifically designed to follow AdvanTex® Treatment Systems. It can be also be mounted inside of the AX20-RT Treatment System.

*The Orenco® UV Disinfection Unit is unlike any other disinfection unit on the residential wastewater market. It dramatically reduces bacteria and viruses, when used as directed.*



*Warning: UV radiation burns retinas and skin! Do not look directly at an operating UV lamp or expose skin to UV lamp light!*

## To Order

Call your nearest Orenco Systems®, Inc. Distributor. For nearest Distributor, call Orenco at 800-348-9843, or visit [www.orenco.com](http://www.orenco.com) and click on "Where to Buy."

## Standard Features & Benefits

### Better Product

- UL-recognized
- NSF® equivalency tested
- Fecal coliform reduction of 99.999% (5 logs)
- Flow path designed to maximize contact time between effluent and lamp
- Unit comes fully-assembled
- Components designed to work together; no piecemeal disinfection units and wiring
- Quick-disconnect coupling makes unit easy to remove for inspection and cleaning
- Teflon® sleeve ...
  - protects lamp
  - reduces breakage
  - minimizes buildup
  - minimizes service intervals
  - makes cleaning easy
- Yearly service interval and lamp replacement

### Better Controls

- Power ballast and lamp current sensor housed in control panel (not a tank or wet well) to minimize corrosion and failure due to environmental exposure
- Panel prevents discharge of non-disinfected effluent due to lamp failure or control panel failure<sup>1</sup>
- Audible and visible alarm activated if lamp fails<sup>2</sup>
- E-mail alert sent if lamp fails<sup>3</sup>
- For more information, call Orenco at 800-348-9843 or 541-459-4449

<sup>1</sup> AXUV only

<sup>2</sup> AXUV or UVIB panel only

<sup>3</sup> AXUV with VCOM® panel only

# Orenco®

Orenco Systems®, Incorporated



UV Disinfection Unit Components

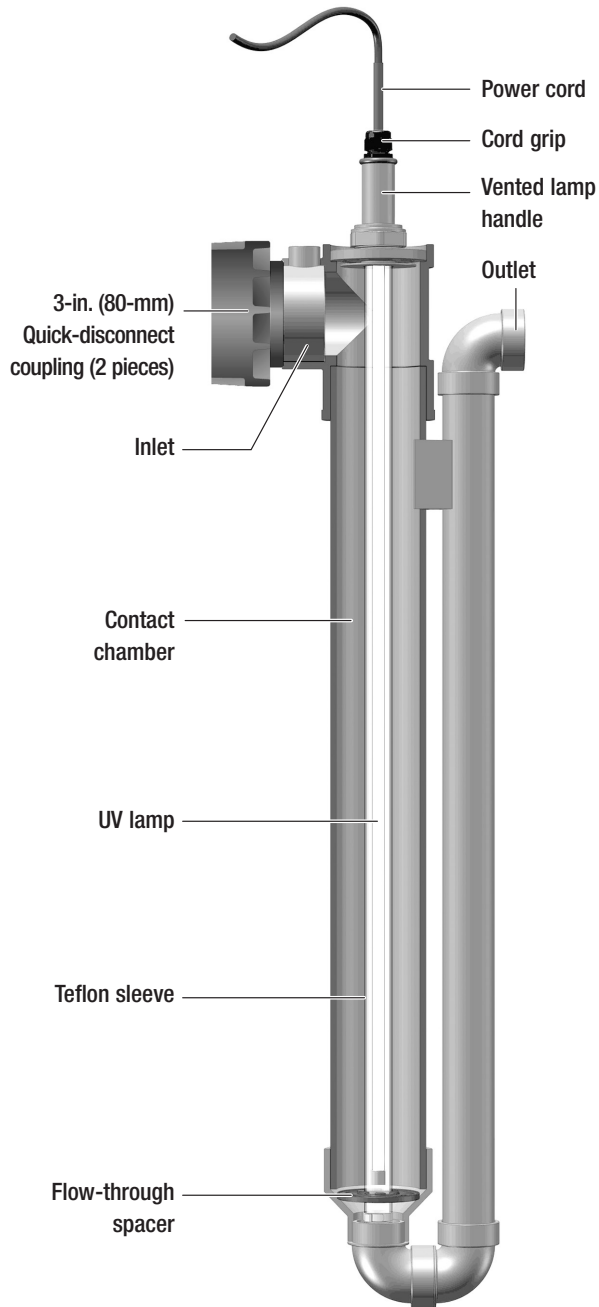

Performance

Typical contact chamber UV dose (65% transmittance, 20% lamp degradation)	276,000 $\mu\text{W}\cdot\text{s}/\text{cm}^2$ at 1 gpm (0.06 L/sec) 55,000 $\mu\text{W}\cdot\text{s}/\text{cm}^2$ at 5 gpm (0.32 L/sec) 28,000 $\mu\text{W}\cdot\text{s}/\text{cm}^2$ at 10 gpm (0.63 L/sec)
Minimum target dose	30,000-38,000 $\mu\text{W}\cdot\text{s}/\text{cm}^2$
Lamp	31 in. (787 mm), 92 VAC, 50 or 60 Hz, 425 mA, 38 W; 254 nm UVC intensity at 1m is 125 $\mu\text{W}/\text{cm}^2$
Power cord length	600V, 18/2 UL Type TC, 25 ft (7.62 m) std
Cord plug	UL listed four-pin connector, lamp-holder, electric discharge, 1000 V or less
Ballast	120 VAC, 50 or 60 Hz, located in UL listed Orenco® control panel
Circuit breaker	10 A, OFF/ON switch; Single-pole 120 V*, DIN rail mounting with thermal magnetic tripping characteristics
Audible alarm*	95 dB at 24 in. (610 mm), warble-tone sound
Visual alarm*	7/8-in. (22-mm) diameter red lens, "Push-to-silence," UL Type 4X rated, 1 W LED light, 120 V

\* Standard on VeriComm, MVP, and UVIB panels. Not available with UVIBSUB panels.

Model Codes for Ordering

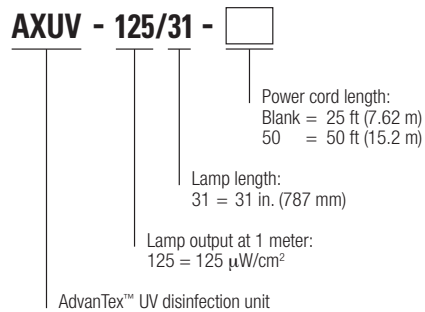
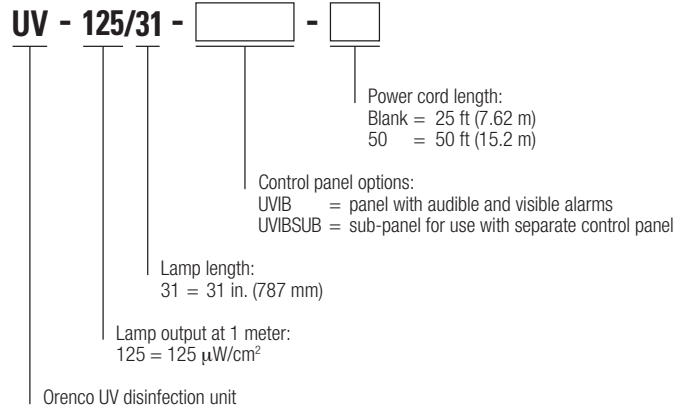



**And this is a wastewater dispersal field.  
No Worries.**

**GEOFLOW**  
SUBSURFACE DRIP SYSTEMS



## Geoflow WASTEFLOW®

Geoflow's subsurface drip systems solve many of the problems that plague traditional methods of wastewater dispersal. Since the effluent is dispersed underground where it is absorbed in the biologically active soil layer, there is no surface contamination, no ponding, no run-off problems, no bad smells.

Issues such as overspray and aerosol drift are eliminated, dose scheduling is unaffected by land use or weather, and it is a politically and environmentally favorable means of dispersing wastewater.

With subsurface drip, secondary reclaimed wastewater can be used, eliminating the ongoing cost of additional effluent treatment.

Geoflow drip dispersal is recommended for commercial, municipal, industrial, residential and agricultural applications.



Subdivision in Minnesota.

## How It Works

The WASTEFLOW dripline has factory-installed emitters evenly spaced along the tubing. The dripline is usually installed six to ten inches below the surface, directly into the biologically active soil horizon where the treated effluent can be absorbed by the plants, animal life, and soil.

Wastewater is pumped to the dripfield on a time-activated dose cycle. The slow, even application of effluent with resting periods is key to the drip system's success.

## Easy To Install — New or Retrofit

Geoflow subsurface systems are simple to install. The tubing can be laid on a graded parcel then covered with topsoil or installed using a tubing plow or trencher.

Subsurface drip also solves the problem of small or odd-shaped areas, such as property edges and around buildings and other structures. The flexible tubing can easily be fit to uneven spaces. Since the wetted area is within close proximity of each emitter, run-off problems are easily eliminated.



Plow single or multiple driplines at a time.

## But What About...?

**Clogging** — Geoflow drip systems are installed with self-cleaning filters to keep large particles from entering the drip field.

WASTEFLOW emitters are also self-cleaning and have been used for over 15 years in actual onsite applications. They are made with large orifices, raised entry ports, and turbulent flow paths to keep smaller particles from collecting in the emitters.

**Root intrusion** — Each emitter features ROOTGUARD<sup>®</sup>, patented protection against roots entering the emitters. The non-toxic active ingredient, Treflan<sup>®</sup>, directs root growth away from the emitters. Treflan is impregnated into the emitters during the molding process.

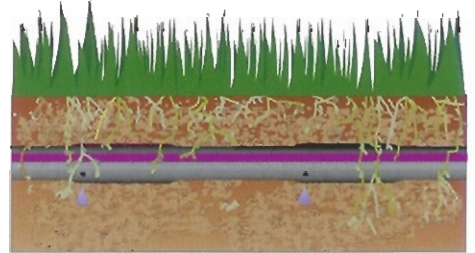

Rootguard keeps roots from penetrating and clogging the emitters.

**Bacterial growth** — Geoflow's WASTEFLOW dripline is coated inside with the anti-bacterial, *Ultra-Fresh*<sup>®</sup> to inhibit bacterial growth on the walls of the tube and in the emitters. *Ultra-Fresh* has been found to be effective in preventing slime build-up inside the tube, even with effluent that has very high BOD.



Look for the anti-bacterial turquoise lining.

This eliminates the need to scour the dripline with high flush velocities.

There is virtually no discharge into the environment because the active ingredient, TBT-maleate, does not migrate readily through plastic (Note: Ultra-Fresh does not treat the water flowing through the tube.)

**Freezing climates** — Geoflow systems can be used year round, even in freezing conditions. The polyethylene dripline is flexible enough so as not to crack when it freezes. The dripline self-drains through the emitters every time the system is turned off, and will not hold water. Sound design, including drainback of the system, air vacuum breakers and insulation of the more rigid parts of the system keep the system working even in the coldest climates.

**Difficult sites** — Geoflow systems can be effective in areas with

- tight soils,
- rocky terrains,
- steep slopes,
- high water tables.

Design guidelines are available directly from Geoflow and at [www.geoflow.com](http://www.geoflow.com).



A steep slope installation in California — 65% slope.

## Testimonials

### Higgins Corner Retail Development Nevada County, California

"The Geoflow dripline system proved to be successful in four areas: Foremost, there was a tremendous cost saving in installing the Geoflow system. Secondly, the time and effort saved in installing Geoflow as compared to the construction of deep absorption trenches was also a benefit. Thirdly, one and a half acres of land could be used for other monetary-inducing projects; and fourth, the final disposal site looks like the original untouched property. Neighbors are pleasantly surprised at the final effluent disposal field."

*Mark Kahl, Design Engineer  
7H Technical Services Group Inc.*



Higgins Corner, Nevada County, CA.

### Ocala Airport Ocala, Florida

"The [44-acre] site has operated successfully at an average of 500,000 gpd over a three-year period. Monitoring data reveals that groundwater quality has not been adversely effected despite high loading rates... The cost to operate and maintain a subsurface reuse system is much less than a conventional irrigation system..."

*Ed T. Earnest, P.E. Utility Engineer,  
City of Ocala Engineering Dept.*



Ocala Airport.

### Omaha Beach Golf Course Matakana, New Zealand

"As part of the construction of the new 9-holes the developer installed a new subsurface drip irrigation system on some of the new fairways to act as part of the overall community treated effluent disposal system... We are extremely pleased with the system, which gives a very even deep green appearance to the fairways where it was been installed. The fairways that are irrigated with the subsurface drip system are in better condition than those that do not yet have the system."

*Allan Anderson,  
Head Greenkeeper*



Omaha Beach Golf Course, N.Z.

## Typical Layout

WASTEFLOW dripline is made of flexible 1/2" polyethylene tubing coated on the inside with an anti-bacterial lining to inhibit bacterial growth. The factory-installed emitters are spaced evenly along the tubing.

The dripline is placed six to ten inches below the surface, directly into the biologically active soil horizon. Effluent is pumped on a time-activated dose cycle through a self-cleaning filter out to the dripfield, providing slow, even application of effluent.

The system returns back to the pump tank or treatment tank in a closed loop, and is kept clean with regular flushing.

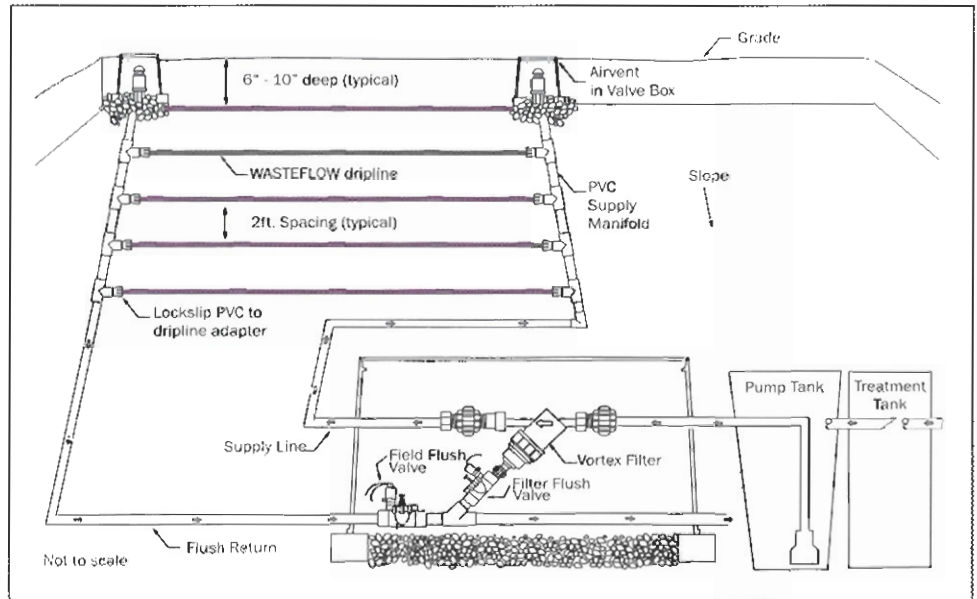

Typical disposal field elements and layout

## The Drip Emitters

Geoflow offers two different emitters, the Classic and the PC.



WASTEFLOW Classic



WASTEFLOW PC

Each dripper has a filter built in at the entry port to keep particles out.



### Turbulent flow path

Effluent travels through a turbulent flow path that helps keep any fine particles from settling inside the dripper.

### CUTAWAY OF THE PC EMITTER



**Dose mode** – When pressurized, the rubber diaphragm flexes across the compensating chamber to regulate flow across 7 to 60 psi.



**Flushing mode** – As the pump is powered on and off again, the rubber diaphragm relaxes across the exit hole enabling the dripper to self-flush every cycle.

## Geoflow Team

The people at Geoflow are the subsurface drip experts. We offer training, answers to your questions, and support every step of the way from concept through design and installation.

**Geoflow dripline comes with an unprecedented 10-year limited warranty for root intrusion, workmanship and materials.**

### GEOFLOW, INC.

506 Tamal Plaza  
Corte Madera, CA 94925  
[www.geoflow.com](http://www.geoflow.com)

Tel: (800) 828-3388  
Fax: (415) 927-0120

WASTEFLOW is manufactured under U.S. patents 5,332,160 and 5,116,414, and foreign equivalents. WASTEFLOW and ROOTGUARD are registered trademarks of A.I. Innovations. Treflan is a registered trademark of Dow AgroSciences. Ultra-Fresh is a registered trademark of Thomson Research Associates, Inc., Canada.

**GEOFLOW**  
SUBSURFACE DRIP SYSTEMS

Look for the purple stripe on the tubing to be sure you are getting Geoflow!

## Appendix B

---

# Onsite System Upgrade Options and Cost Estimates

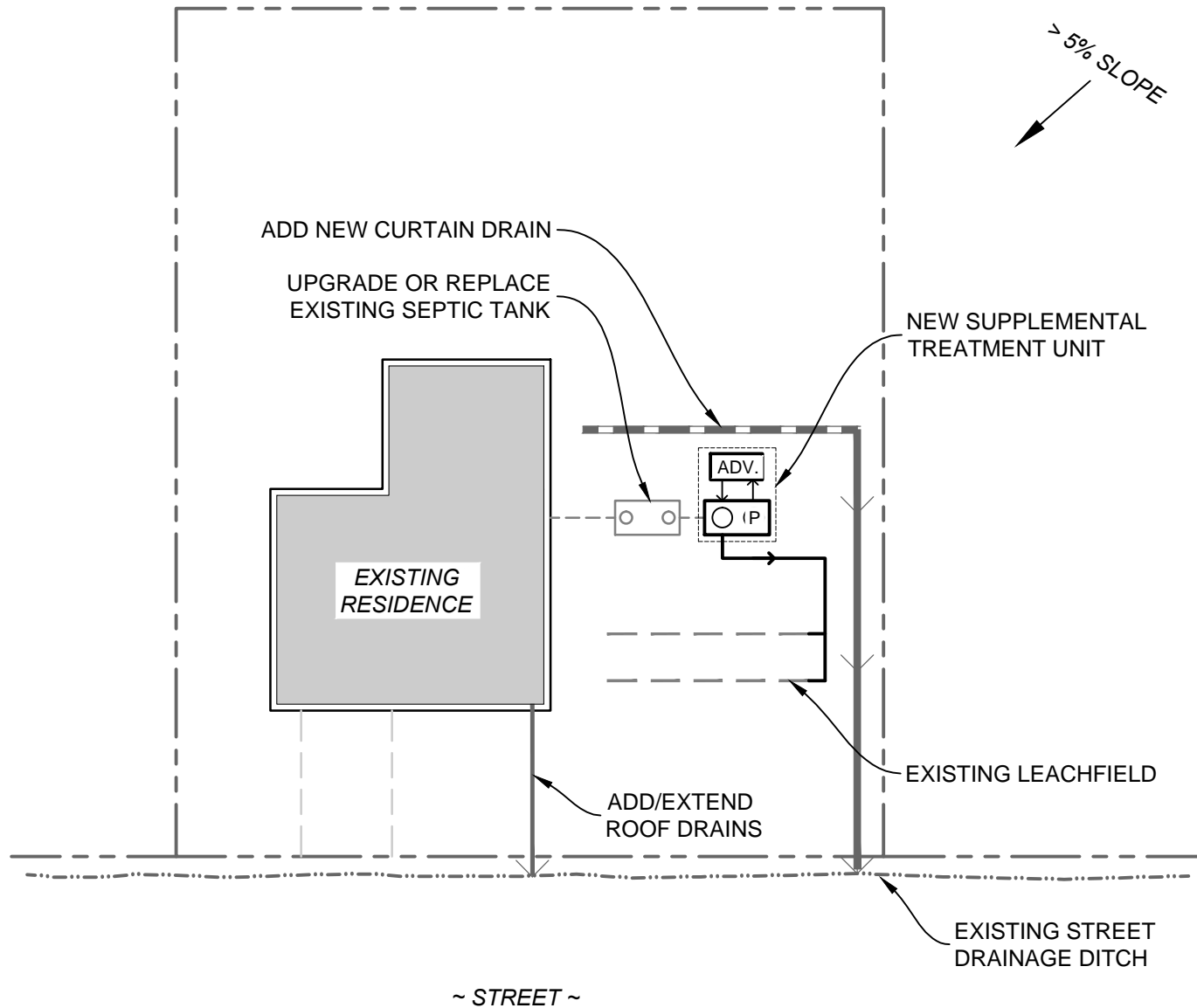

Sl#	Rev	Date	By	Description	App'd

Design: NH/PP  
Drawn: ML  
Checked: PP  
App'd: NH

D:\STAFF\WOODACRE\WOODACRE\_WASTEWATER\_FEASIBILITY\FIGURE\_B-1.DWG





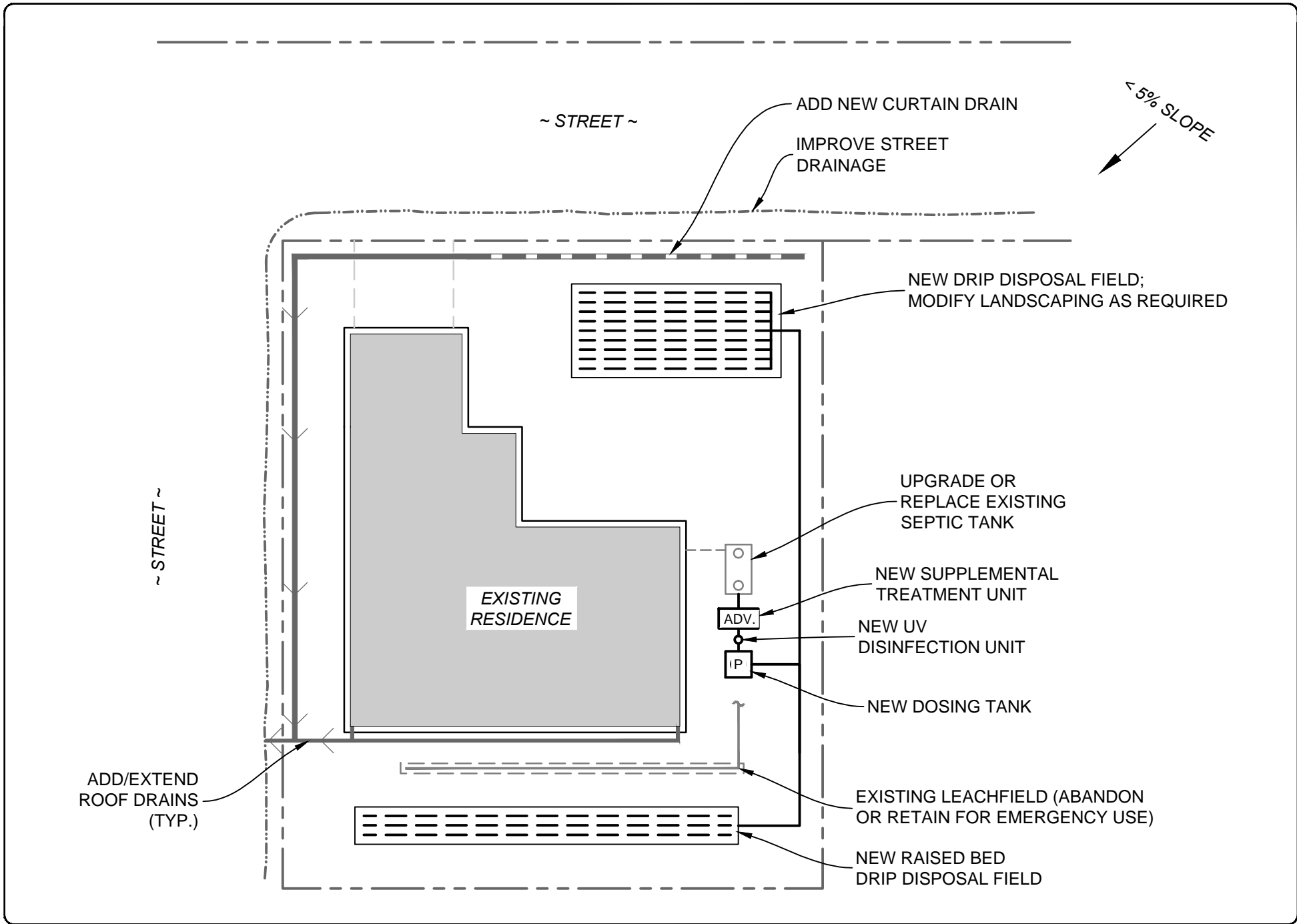

**WOODACRE/SAN GERONIMO FLATS  
WASTEWATER FEASIBILITY STUDY**  
WOODACRE, CALIFORNIA

**QUESTA**  
ENGINEERING CORP.  
Civil Environmental & Water Resources  
©10 238-6114  
FAX 910 238-2623  
P.O. Box 70356 1220 Birchyard Cove Road Point Richmond, CA 94807

Sl#	Rev.	Date	By:	Description:	App'd:

Design: NH/PP  
Drawn: ML  
Checked: pp  
App'd: NH

**ON-SITE UPGRADE EXAMPLE  
TREATMENT, DISPOSAL FIELD, & DRAINAGE**

Size: D Project: 1600073  
Scale: AS NOTED  
FIGURE: B-3

DATE: 10/10/17 10:00 AM 10/10/17 10:00 AM 10/10/17 10:00 AM 10/10/17 10:00 AM

**Preliminary Construction Cost Estimate**  
**Alternative 2 - Onsite Upgrades & Management Program**  
**MODERATE LEVEL WORK**  
**Add Supplemental Treatment & Drainage Improvements**

ITEM	UNIT	QTY	UNIT COST (\$)	TOTAL COST (\$)
<b>I. SITE PREPARATION &amp; MOBILIZATION</b>	LS	1		\$1,500
<b>II. SEPTIC TANK</b>				
Inspect, waterproof, upgrade risers, inlet & outlet	LS	1		\$1,000
<b>III. SUPPLEMENTARY TREATMENT</b>				
Install AdvanTex & Controls	LS	1		\$9,500
<b>IV. DISPERSAL SYSTEM - EXISTING GRAVITY</b>				
Inspect, add observation wells, pipe connections	LS	1		\$1,000
<b>V. DRAINAGE IMPROVEMENTS</b>				
Install new curtain drain	LF	100	75	\$7,500
Surface drainage improvements	LS	1		\$1,500
<b>VI. ELECTRICAL</b>	LS	1		\$1,500
<b>VII. SITE RESTORATION &amp; DEMOBILIZATION</b>	LS	1		\$1,500
<b>VII. INSPECTION/TESTING</b>	LS	1		\$500
<b>IX. PERMITTING</b>	LS	1		\$2,000
			<b>TOTAL</b>	<b>\$27,500</b>

**Preliminary Construction Cost Estimate**  
**Alternative 2 - Onsite Upgrades & Management Program**

**MODERATE LEVEL WORK**  
**Add PD Leachfield & Drainage Improvements**

ITEM	UNIT	QTY	UNIT COST (\$)	TOTAL COST (\$)
<b>I. SITE PREPARATION &amp; MOBILIZATION</b>	LS	1		\$1,500
<b>II. SEPTIC TANK</b>				
Inspect, waterproof, upgrade risers, inlet & outlet	LS	1		\$1,000
<b>III. CONVERT/ADD NEW PD LEACHFIELD</b>				
New dosing tank	LS	1		\$5,000
Dosing pump & controls	LS	1		\$2,500
New PD leachfield	LF	100	50	\$5,000
Modify existing leachfield piping	LS	1		\$500
<b>V. DRAINAGE</b>				
Install new curtain drain	LF	100	75	\$7,500
Surface drainage improvements	LS	1		\$1,500
<b>VI. ELECTRICAL (UPGRADE)</b>	LS	1		\$1,500
<b>VII. SITE RESTORATION &amp; DEMOBILIZATION</b>	LS	1		\$1,500
<b>VII. INSPECTION/TESTING</b>	LS	1		\$500
<b>IX. PERMITTING</b>	LS	1		\$2,000
			<b>TOTAL</b>	<b>\$30,000</b>

**Preliminary Construction Cost Estimate**  
**Alternative 2 - Onsite Upgrades & Management Program**  
**HIGH CONSTRAINTS AND WORK LEVEL**

**Add Treatment, Drip Field & Drainage Improvements**

ITEM	COST RANGE (\$)	
	Low Estimate	High Estimate
<b>I. SITE PREPARATION &amp; MOBILIZATION</b>	\$1,500	\$1,500
<b>III. SEPTIC TANK</b>		
Inspect, waterproof, upgrade risers, inlet & outlet	\$1,000	
Abandon existing septic tank		\$1,500
Install new septic tank		\$5,500
<b>IV. SUPPLEMENTARY TREATMENT</b>		
AdvanTex & Controls	\$9,500	\$9,500
UV Unit		\$1,000
<b>IV. DRIP DISPERSAL SYSTEM</b>		
Dosing Tank	\$4,500	\$5,000
Pump and Controls	\$2,500	\$2,500
Drip Piping and Valves	\$2,500	\$3,500
Raised Bed Soil Fill		\$5,000
<b>V. DRAINAGE IMPROVEMENTS</b>		
Install new curtain drain	\$7,500	\$7,500
Surface drainage improvements	\$1,000	\$1,500
<b>VII. ELECTRICAL (UPGRADE)</b>	\$1,500	\$1,500
<b>VIII. SITE RESTORATION &amp; DEMOBILIZATION</b>	\$1,500	\$2,500
<b>VIII. INSPECTION/TESTING</b>	\$1,000	\$1,000
<b>IX: PERMITTING</b>	\$2,000	\$2,000
<b>TOTAL</b>	\$36,000	\$51,000

**Estimated Capital Costs**  
**Alternative 2 - Onsite System Upgrade and Management Program**

<b>Upgrade Work Category</b>	<b>Number of Systems</b>	<b>Average Cost per System</b>	<b>Total Cost (\$)</b>
Low Level	54	\$3,000	\$162,000
Moderate Level	43	\$28,750	\$1,236,250
High Level	263	\$43,500	\$11,440,500
<b>Subtotal</b>			<b>\$12,838,750</b>
<b>Contingency @ 15%</b>			<b>\$1,925,813</b>
<b>Subtotal</b>			<b>\$14,764,563</b>
<b>Engineering and Environmental Studies @ 15%</b>			<b>\$2,214,684</b>
<b>Construction Management @ 10%</b>			<b>\$1,476,456</b>
<b>Project Admin, District Formation and Financing @ 5%</b>			<b>\$738,228</b>
<b>TOTAL</b>			<b>\$19,193,931</b>
<b>Average Cost Per Connection (360 parcels)</b>			<b>\$53,316</b>

**Estimated Annual Operation and Maintenance Costs  
Alternative 2 - Onsite System Upgrade and Management Program**

Items	Assumptions	Estimated Annual
District/Program Administration	Insurance, legal, financial, permits @ \$150/parcel	\$54,000
On-lot System Inspection, Monitoring & Reporting	Annual inspection of all systems, remote monitoring, data compilation, annual reporting, as-needed engineering consultation @ \$300 ea	\$108,000
Maintenance	Equipment, materials, maintenance & replacement @ \$200/yr each	\$72,000
Laboratory & Expenses	Sampling 20% of individual treatment systems annually, surface and groundwater sampling, travel expenses and supplies	\$36,000
Electrical*	Property owner expense for treatment & dispersal pumps and other electro-mechanical items @ \$30/yr	\$10,800
Septic Tank Pumping*	25% of tanks pumped annually @ \$400 each	\$36,000
<b>Subtotal</b>		<b>\$316,800</b>
Contingencies (@ 10%)		\$31,680
<b>TOTAL</b>		<b>\$348,480</b>
<b>ANNUAL COST PER PARCEL (360)</b>		<b>\$968</b>

\* Direct cost to property/system owner, varies according to system use

Appendix C

---

# Fire Road Community Leachfield Information

## APPENDIX C

### FIRE ROAD COMMUNITY LEACHFIELD - ALTERNATIVE 3

The following information regarding site conditions and community leachfield options at the Fire Road site is from the 2011 Woodacre Flats Wastewater Feasibility Study.

#### Fire Road Site Conditions

As part of the 2011 Woodacre Flats Wastewater Feasibility Study, field reconnaissance investigations were conducted on several large properties in the Woodacre area to identify sites that might be suitable and of sufficient size to accommodate a community wastewater disposal system. A few potential sites were located on the Dickson Ranch property and on lands owned by the Tamalpais Union High School District, east of Woodacre. Based on the amount of area, soil conditions, and land owner interests and concerns, the most promising site identified was an approximately 1.5-acre wooded knoll on Dickson Ranch property located along the Fire Road ridgeline. This is referred to as the Fire Road Site and, from preliminary analysis, was estimated to have sufficient capacity to accommodate a community leachfield system of the size required to serve the Woodacre Flats area.

The Fire Road Site was initially identified as a potential area of interest from review of air photos, and topographic and geologic maps. It lies on a portion of the ridgeline composed of sandstone. The area considered suitable for a community leachfield a 1.5-acre knoll, extending approximately 1,000-feet along the ridgeline in a southeast-northwest direction, sloping predominantly to the north and northeast at grades varying from about 5 to 20 percent. A small portion of the site (estimated 5 to 10 percent) drains in a southwesterly direction toward Woodacre. Immediately north of the knoll, the slopes steepen considerably to greater than 30%, which continue downhill to San Geronimo Valley Drive. The knoll is wooded, mostly with bay trees, a few oaks and Douglas fir, and two distinct clusters of redwoods. There is a limited amount of understory vegetation. The steeper hillslopes to the north and northeast are densely wooded, with predominantly with redwoods and Douglas fir. There is no development on the site or on any lands between the site and San Geronimo Valley Drive.

As a result of its topographically high position, there are no watercourses on or within 200 to 300 feet of the Fire Road site. Runoff from the site is dispersed by sheet flow, and is slowed by the gentle slopes, vegetative cover, and sandy soil conditions. Farther down the hillslope to the north and northeast, swales form which eventually become seasonal drainages at the base of the hillslope near San Geronimo Valley Drive. There are no known wells on the site or in the immediate vicinity. The nearest well an agricultural supply well located approximately 600 feet to the southeast.

Following initial hand-auger soils inspection, four exploratory test pits were excavated in the Fire Road site by Questa on June 4, 2010, to evaluate soil suitability for wastewater disposal. Test pit locations are shown in **Figures C-1, C-2 and C-3**. All test pits showed similar soil conditions, consisting of loam and sandy loam topsoils underlain by highly weathered sandstone to the depth explored. No groundwater or evidence of seasonal saturation was observed in any of the profiles. **Table C-1** summarizes the soil profiles logs.



**Table C-1: Soil Profile Summary, Fire Road Site**

Test Pit #	Depth (inches from surface)	Soil Description
T-1	0 - 21	Loam
	21 - 66	Very weathered sandstone
	66 - 90	Very weathered sandstone, increasing density
T-2	0 - 24	Fine sandy loam
	24 - 66	Highly weathered sandstone; textures to sandy clay loam
	66 - 78	Weathered sandstone, very soft and friable
T-3	0 - 16	Loam to sandy loam
	16 - 72	Weathered sandstone, variable from sandy loam to sandy clay
T-4	0 - 28	Sandy loam
	28 - 60	Very weathered sandstone; textures to sandy loam

No percolation testing conducted; however, based on the observed sandy soil conditions and experience with other similar soils in the Woodacre area, soil percolation rates are estimate to be in the range of 5 to 15 minutes per inch (MPI), with faster rates in the upper 2 to 3 feet and becoming slower with depth. These percolation rates would be suitable for disposal of either primary/septic tank effluent or secondary treated wastewater effluent, making the site feasible for a variety leachfield designs, including standard and pressure distribution trenches (2 to 5-foot deep), mound systems, or subsurface drip dispersal. Formal percolation testing in accordance with standard Marin County procedures should be conducted prior to final project selection and design to verify percolation rates and leachfield sizing for the service area and wastewater flows to be accommodated.

### Community Leachfield Options

Based on the favorable soil and site conditions along with the amount of available land area, several different design options and configurations were considered for the Fire Road site. This resulted in the development of three different community leachfield options, identified as Alternatives 3A, 3B and 3C, and illustrated in **Figures C-1, C-2 and C-3**, respectively. The following briefly describes these alternatives.

- **Alternative 3A.** The first Fire Road option is a shallow pressure distribution leachfield system for disposal of septic tank effluent. The trenches would be constructed with the use of Infiltrator Chambers to eliminate the need for hauling large quantities of drain rock to the Fire Road site. The trenches would be 30-inches deep and 36-inches wide, with

an effective wastewater application area of 5 ft<sup>2</sup> per lineal foot. This is based on the combination of 3-ft wide bottom area plus 12 inches sidewall area (two sides), following sizing criteria contained in the RWQCB Minimum Guidelines. Minimum trench spacing would be 6 feet (on centers); however a spacing of 10 feet was assumed to provide a reasonable margin of safety for avoidance of trees and other local incongruities in the topography. Using an average percolation rate of 10 minutes per inch (MPI) would give a wastewater loading rate of 0.8 gpd/ft<sup>2</sup>, or 4.0 gpd/lineal foot of trench. Although the use of Infiltrator Chambers is recommended, if rock-filled trenches are preferred from a regulatory standpoint or for other reasons, the trench dimensions and overall sizing would be the same as presented above. No extra capacity credit is assumed for the use of Infiltrator Chambers in this analysis. The costs for rock-filled trenches and rock-hauling impacts would be greater than for the recommended Infiltrator Chamber design.

The available disposal area at the Fire Road site is estimated to be approximately 65,000 to 66,000 square feet, which would accommodate approximately 6,500 to 6,600 lineal feet of trench at 10-foot o.c. trench spacing. At the above wastewater loading assumptions, leachfield capacity could be provided up to approximately 26,400 gpd.

- **Alternative 3B.** The second option considered for Fire Road included a secondary treatment system that would have the effect of reducing the required leachfield area by one-half compared with Alternative 3A. Using the same pressure distribution system design as for Alternative 3A (including Infiltrator Chambers), the wastewater loading rate would increase two-fold from 0.8 to 1.6 gpd/ft<sup>2</sup>. This would increase the loading rate to 8 gpd/ft<sup>2</sup>, and increase the overall disposal capacity of the site. Using the same trench spacing of 10 feet o.c., the leachfield would occupy approximately half of the available disposal area, leaving enough unused area to serve as a 100% replacement area.

The assumption of a higher wastewater loading rate for dispersal of secondary treated water is derived from Marin County regulations (in effect since 1996) and is supported in technical literature (e.g., U.S. EPA Onsite Wastewater Treatment Systems Manual, 2002). Marin County regulations authorize increased leachfield loading rates (as compared with standard septic tank effluent) for systems that include advanced treatment using either an intermittent sand filter, recirculating sand filter, or packed bed filter such as AdvanTex. For soils with percolation rates up to 90 minutes per inch, the application rate may be increased up to two times the standard rate for septic tank effluent. The scientific rationale is that wastewater with low organic strength (low BOD) reduces the amount of organic material delivered to the soil absorption field, and promotes the maintenance of aerobic soil conditions and microbial populations that are more efficient (as compared with anaerobic bacteria) in assimilating the organic materials in the effluent. The net result is reduced soil clogging and better water transmission through the soil.

- **Alternative 3C.** Using the same secondary treatment system as 3B, Alternative 3C would include a subsurface drip dispersal system in lieu of the shallow pressure distribution leachfield system included in the other two Fire Road alternatives.

The drip dispersal system uses a specially manufactured dripline, such as Geoflow Wasteflow<sup>TM</sup>, developed for wastewater applications. Technical literature describing subsurface drip dispersal equipment and design/installation procedures is provided in **Appendix A**. In brief, the dripline consists of 1-inch diameter polyethylene tubing with pressure-compensating emitters spaced 12 to 24 inches apart. The driplines are

typically installed at a depth of 6 to 12 inches in below ground surface, and up to 18 inches in wooded areas. Spacing between driplines depends is typically 24 inches, although it can be varied around vegetation. The drip dispersal system would be organized into a series of zones (of roughly equal disposal capacity) to be dosed from the central wastewater effluent dosing station at the disposal site.

The sizing and design of the drip field would follow criteria contained in Marin County sewage disposal regulations and manufacturer recommendations. The sandy/loamy soil conditions at the site would warrant a wastewater application rate in the range of 0.6 to 1.0 gpd/ft<sup>2</sup>, based on the surface area of the disposal field. Using an average value of 0.8 gpd/ft<sup>2</sup>, the required disposal area for a design flow of 26,400 gpd would be about 33,000 square feet. Including an additional 100% reserve field, the required area would be double, or about 66,000 square feet. The estimated 65,000 to 66,000 square feet at the Fire Road site would accommodate both a 100% primary and 100% reserve drip field, or dual alternating fields.

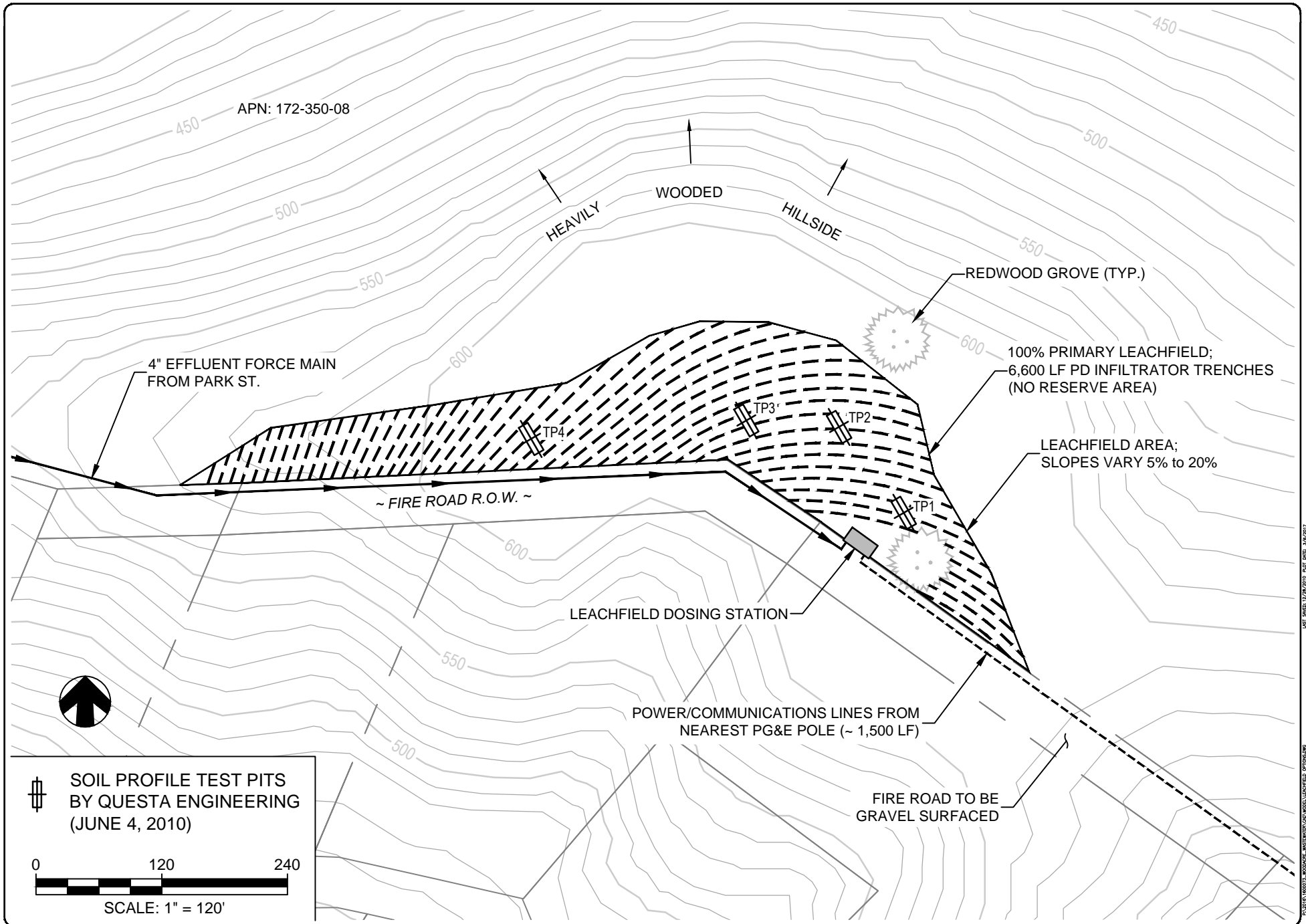

**SOIL PROFILE TEST PITS  
BY QUESTA ENGINEERING  
(JUNE 4, 2010)**

SCALE: 1" = 120'

**WOODACRE/SAN GERONIMO FLATS  
WASTEWATER FEASIBILITY STUDY**  
 WOODACRE, CALIFORNIA

**QUESTA**  
 ENGINEERING CORP.  
Civil Environmental & Water Resources  
 010 236-6114  
 FAX 010 236-6203  
 P.O. Box 70356 1220 Birchyard Cove Road Point Richmond, CA 94807

Sl#	Rev.	Date	By	Description	App'd

Design: NH/PP  
 Drawn: ML  
 Checked: pp  
 App'd: NH

**ALTERNATIVE 3A - FIRE RD LEACHFIELD  
PRIMARY TREATMENT - PD LEACHFIELD**

Sheet: D  
 Project: 1600073  
 Scale: AS NOTED  
 FIGURE: C-1

DATE: 12/29/2010 10:43:57 AM

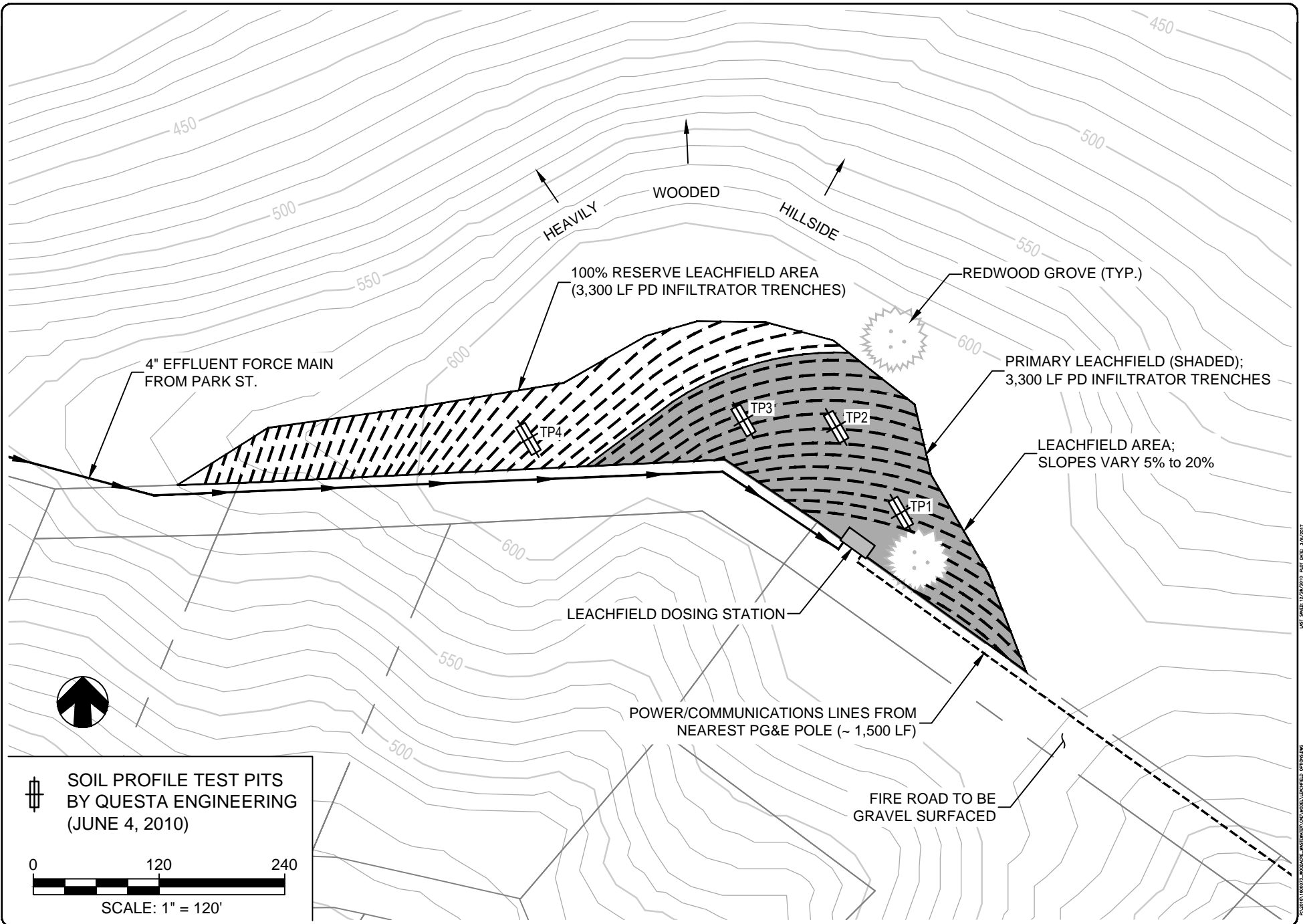

**SOIL PROFILE TEST PITS  
BY QUESTA ENGINEERING  
(JUNE 4, 2010)**

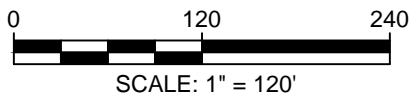

**WOODACRE/SAN GERONIMO FLATS  
WASTEWATER FEASIBILITY STUDY**  
 WOODACRE, CALIFORNIA

  
 Civil Environmental & Water Resources  
 010 236-6114  
 FAX 010 236-6203  
 P.O. Box 70356 1220 Birchyard Cove Road Point Richmond, CA 94807

Sl#	Rev.	Date	By	Description	App'd

Design: NH/PP  
 Drawn: ML  
 Checked: pp  
 App'd: NH

**ALTERNATIVE 3B - FIRE RD LEACHFIELD  
SECONDARY TREATMENT - PD LEACHFIELD**

Size: D  
 Project: 1600073  
 Scale: AS NOTED  
 FIGURE: C-2

DATE: 12/29/2010 10:43:58 AM

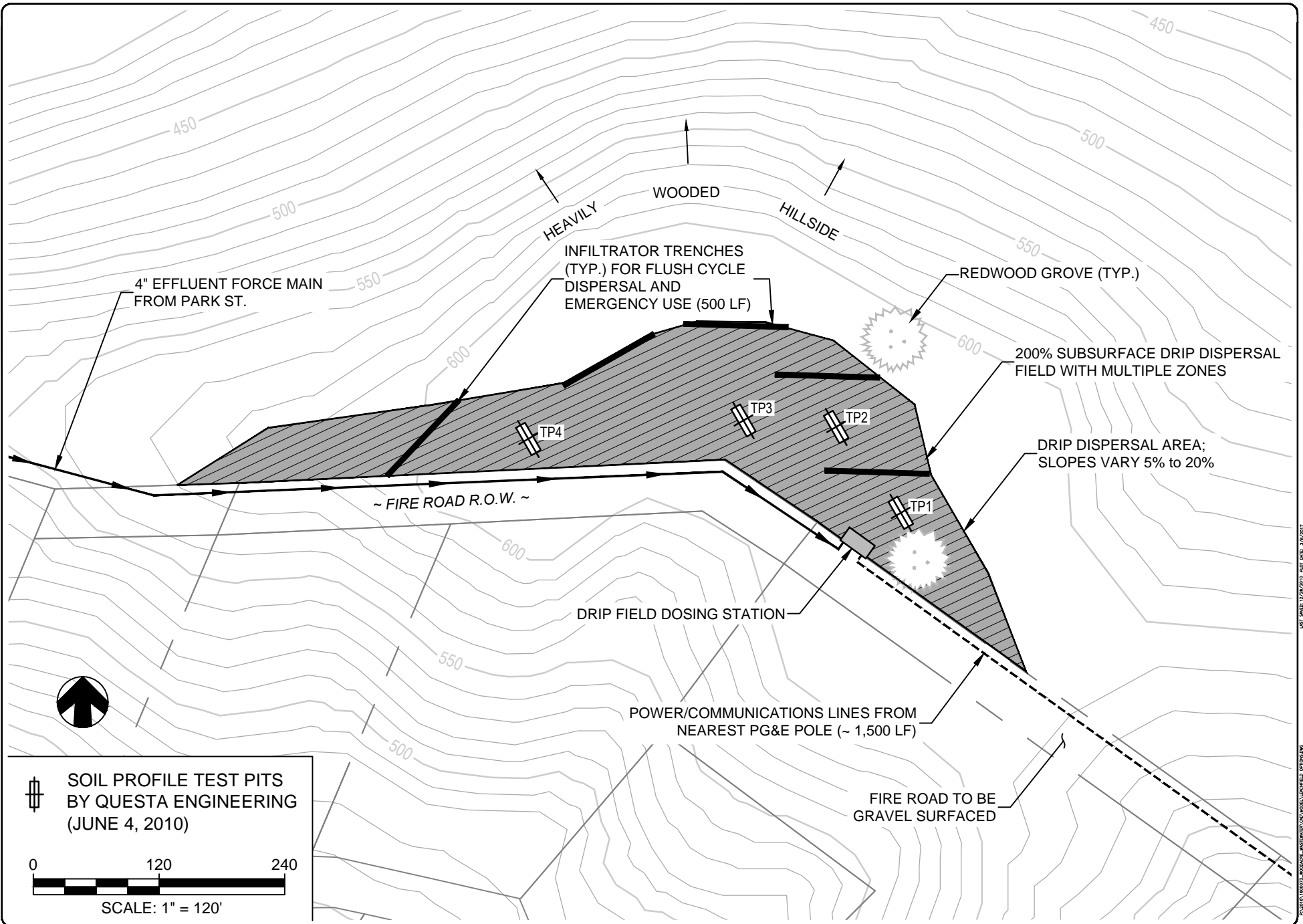

SOIL PROFILE TEST PITS BY QUESTA ENGINEERING (JUNE 4, 2010)

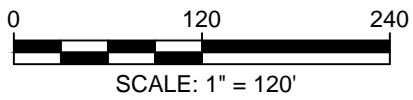

**WOODACRE/SAN GERONIMO FLATS WASTEWATER FEASIBILITY STUDY**  
WOODACRE, CALIFORNIA

**QUESTA ENGINEERING CORP.**  
Civil Environmental & Water Resources  
1220 Birchyard Cove Road • Point Richmond, CA 94807  
910.236.6114 FAX 910.236.2423

Sl#	Rev.	Date	By	Description	Appr'd

Design: NH/PP  
Drawn: ML  
Checked: pp  
Appr'd: NH

**ALTERNATIVE 3C - FIRE RD LEACHFIELD SECONDARY TREATMENT - DRIP DISPERSAL**

Sheet D Project 1600073  
Scale: AS NOTED  
FIGURE: C-3

DATE: 12/29/2010 11:03 AM; PLOT DATE: 3/4/2017

**Construction Cost Estimate**  
**Alternative 3B - Woodacre - Fire Road Community System**  
**Secondary Treatment and Pressure Distribution Leachfield (200%)**

<b>Design Flow: 26,400 gpd</b>		<b>Service Connections: 176 parcels @ 150 gpd/parcel</b>		
Item	Units	No. of Units	Cost per Unit (\$)	Total Cost (\$)
				<b>Effluent Sewer</b>
<b>Treatment</b>				
Pre-anoxic Tank	GAL	30,000	\$3.50	\$105,000
(1) 10,000-gal Equalization Influent/Effluent Tank	GAL	10,000	\$4.00	\$40,000
(1) 30,000-gal Recirculation Tank & pumps	GAL	30,000	\$4.00	\$120,000
AdvanTex Treatment Units	EA	11	\$30,000	\$330,000
Electrical and Control System	EA	1	\$40,000	\$40,000
Effluent Lift Station - Tanks, Pumps, Controls	GAL	15,000	\$4.00	\$60,000
Site Improvements, Control Building and Fencing	LF	1	\$40,000	\$40,000
<b>Treatment Subtotal</b>				<b>\$735,000</b>
<b>PD Chamber Leachfield System</b>				
Access Road Improvements	SF	15,000	\$4.00	\$60,000
4" Force Main from Park Street	LF	2,200	\$65	\$143,000
(1) 10,000-gal Leachfield Dosing Tank	GAL	10,000	\$3.50	\$35,000
Pumps and Controls	LS	1	\$20,000	\$20,000
PD Chamber Leachfield	LF	6,600	\$50.00	\$330,000
Piping, Valves & Appurtenances	LF	2,000	\$25	\$50,000
Emergency Overflow Dosing Tank & Siphons	LS	1	\$25,000	\$25,000
Electrical Service and Wiring	LS	1	\$60,000	\$60,000
Monitoring Wells	EA	6	\$2,000	\$12,000
Leachfield Fencing	LF	2,500	\$15	\$37,500
<b>Disposal Subtotal</b>				<b>\$772,500</b>
			<b>Total</b>	<b>\$1,507,500</b>

NOTE - Sewer Option: STEP/STEG

\* Primary treatment provided by on-lot septic tanks

**Capital Cost Summary**  
**Alternative 3B - Fire Road Community Leachfield**  
**Woodacre - San Geronimo Wastewater Feasibility Study**  
**Effluent Sewers, Secondary Treatment, PD Chamber Leachfield (200%)**

Cost Item	Estimated Capital Cost (\$)
	Alternative 3B 26,400 gpd 176 Connections
Collection System (Effluent STEP/STEG)	\$ 2,697,175
Treatment Plant	\$735,000
Disposal System	\$772,500
Land/Easement Cost	\$100,000
Mobilization/Demobilization	\$100,000
Permit Fees & Encroachment Fees	\$30,000
<b>Sub-total</b>	<b>\$4,434,675</b>
Contingency @ 15%	\$665,201
<b>Sub-total</b>	<b>\$5,099,876</b>
Engr & Environ Studies @ 15%	\$764,981
Construction Management @ 10%	\$509,988
Admin, Dist Formation, Financing @ 5%	\$254,994
<b>Total Estimated Cost</b>	<b>\$6,629,839</b>
<b>Estimated Cost Per Connection</b>	<b>\$37,670</b>

Assumes use of STEG/STEP collection system  
Collection system throughout extended Woodacre study area



Appendix D

---

# Wastewater Collection Systems

## APPENDIX D WASTEWATER COLLECTION SYSTEMS

### 1.0 INTRODUCTION

Provided here is a review of different methods of sewage collection for use in connection with a community wastewater system for the Woodacre-San Geronimo Flats study area. The basic types of sewage collection methods reviewed include:

- Conventional Gravity Sewers
- Pressure Sewers, with individual grinder pumps
- Small Diameter Effluent Sewers, including Septic Tank Effluent Pump (STEP) and Gravity (STEG).

Included are a general overview of each type of sewage collection system, along with typical advantages, disadvantages and operation and maintenance for each method. Preliminary layouts of collection system options for Woodacre and San Geronimo sub-areas are provided based on review of topographic mapping of the service area, supplemented with field reconnaissance inspections. These represent best professional judgement of the range of options for sewage collection suitable for feasibility analysis. Further study during project design could reveal changes in alignments or other refinements that may result in improvements or cost savings. The collection system layouts provide the information needed to define the expected routing of sewer lines, estimation of the need for individual pump systems, and the probable locations of sanitary lift station(s). The information also provides basic data for preliminary hydraulic analysis of pumping requirements and an estimation of pipe sizes and corresponding costs.

### 2.0 CONVENTIONAL GRAVITY SEWERS

#### General Description

In a conventional gravity sewer, untreated wastewater travels through a system of sewer pipes installed at a minimum grade to maintain gravity flow. Sewer pipes are usually six or eight-inch minimum diameter, with four-inch diameter lateral connections from buildings, and typically require a minimum of 4.5 feet of backfill cover. Pipe and fitting material can be PVC, ABS, high density polyethylene (HDPE) or ductile iron. Conventional gravity sewers require manholes generally: (a) at all intersections of sewer lines other than side sewer connections less than six inches in diameter; (b) at all vertical or horizontal angle points; and (c) at intervals not greater than 400 feet. Manholes provide access for maintenance and cleaning. Since conventional gravity sewers require a constant downhill grade, gravity sewer mains may need to be installed at considerable depths where the terrain is flat or undulating.

## Advantages and Disadvantages

### *Advantages*

Conventional sewers are normally cost effective and appropriate in densely developed areas. The primary advantage of conventional sewers is the proven long-term reliability, long service life, and relatively low operation and maintenance (O&M) costs. Maintenance requirements for gravity sewers consist of routine cleaning of the sewer pipes and maintenance of lift stations. Another advantage is that construction techniques for conventional gravity sewers are familiar to most construction contractors and maintenance personnel.

### *Disadvantages*

The typical disadvantages of conventional gravity sewers include costly and infeasible construction due to sparse population, flat terrain, high groundwater, shallow bedrock, or unstable soils. Infiltration from groundwater leaking into the sewers and inflow from direct storm water runoff into the sewers are an almost unavoidable component of conventional gravity sewers. Infiltration and inflow (I/I) may burden the treatment facility with sewage flows beyond capacity during wet weather. However, I/I can be mitigated by using high-quality pipe materials and construction along with an ongoing preventative maintenance program.

## Operation and Maintenance

Operation and maintenance activities for a conventional gravity sewer system consist of cleaning the sewers, monitoring sewers for illegal inflow connections, and pump station operation and maintenance. Pump station O&M involves repair and maintenance of mechanical, electrical and structural equipment. Access for cleaning is provided by manholes (6-inch and 8-inch gravity sewers) and by clean-outs (for 4-inch laterals). Cleaning of gravity sewers may require removal of obstructions from time to time, as well as flushing. Video inspection of sewer lines is also typically performed periodically as a preventative measure and/or to investigate specific sections of sewer lines.

## 3.0 PRESSURE SEWERS

### General Description

Pressure sewers are one of the most popular and successful alternatives to conventional gravity sewers. A pressure sewer is a small diameter pipeline, which is installed following the profile of the ground. Typical main diameters are 2 to 6 inches, and PVC and HDPE are the usual piping material. Burial depths usually have a 30-inch minimum cover.

In residential areas served by a pressure sewer, each home uses a small grinder pump to discharge to the main line (**Figure D-1**). A typical grinder pump and connection detail is provided in **Figure D-1**. The pump grinds the solids in the wastewater into slurry in the manner of a kitchen sink garbage grinder. Grinder pumps to serve individual homes usually range from one to two-horsepower in size. Installations using duplex (2) pumps

and/or large horsepower motors can be used to serve several homes with one pumping unit. Multifamily and commercial properties may make use of duplex pump stations designed for larger flows.

The service line leading from the pumping unit to the main is usually 1.25-inch diameter PVC or HDPE. A check valve on the service line prevents backflow, which is insured with a redundant check valve at the pumping unit. If a malfunction occurs, a high liquid level alarm is activated. This alarm may be a light mounted on the outside wall of the home, or it may be an audible alarm that can be silenced by the resident. In the instance of an activated alarm, the resident would notify the sewer service district, which would respond to make the necessary repair.

Where the terrain and land area favorable, pressure sewer systems can also be designed in a “cluster” configuration, where small groups of houses have gravity sewers leading to a common grinder pump unit/station for each “cluster”. The cluster grinder pump units all discharge into the pressure sewer main, which may also have connections from individual grinder pump units.

## Advantages and Disadvantages

### ***Advantages***

With a typical pipe depth of about 36 inches, pressure sewers eliminate the need for the deep excavation, multiple lift stations, and groundwater dewatering and shoring involved in the installation of conventional gravity sewers. The shallow depth, positive pressure, and tight-glued PVC joints or fused HDPE joints also prevent groundwater infiltration and exfiltration, and substantially reduce the potential for stormwater inflow. In many instances, small diameter HDPE pipe can be installed using Horizontal Directional Drilling (HDD) methods, which is typically much less expensive than open-cut trench installation, and greatly reduces the impacts to road pavement, traffic interruption, and hauling requirements for trench bedding material and excavated soils.

### ***Disadvantages***

The main disadvantage of pressure sewers is the added complexity of the large number of pumps and controls that would have to be installed and maintained at the individual residences. Most modern grinder pump units are very reliable, have a relatively long service life, and include built-in alarms to alert the homeowner in the event of a pump failure. Nevertheless, the impact during extended power outages is much greater with pressure sewers due to limited reserve storage at individual pump units and lack of readily available back-up power. Grinder pump units normally provide emergency storage capacity of about 50 to 100 gallons, unless an additional storage tank is added. Some sanitary districts require grinder pumps to be installed with a transfer switch to allow pump operation using a portable generator. Larger commercial or multi-family complexes can be equipped with an automatic backup generator.

Another disadvantage of pressure sewers is the greater reliance upon on-lot facilities. The facilities located on private property require access easements for system maintenance or repair, and much more ongoing interaction with property owners and attention to public relations by the sewer district personnel.

## Operation and Maintenance

On-lot grinder pumps require periodic maintenance and cleaning, which are normally handled by the sewer district; the associated electrical energy costs are absorbed directly by the property owner. Additionally, high-pressure flushing of the pressure sewer lines may be required every few years to scour slime and solids buildup.

### 4.0 SMALL DIAMETER EFFLUENT SEWERS – PUMP (STEP) AND GRAVITY (STEG)

#### General Description

Small diameter, septic tank effluent pump (STEP) and gravity (STEG) sewers are a popular alternative, especially for low density areas and to minimize sewer pipe sizes and deep trench construction. Unlike conventional sewers, primary treatment is provided at each connection by a septic tank, and only the settled wastewater is collected. Where the terrain is appropriate, the septic tank effluent can be collected by gravity flow (STEG system) in a common small diameter collection main. Where the terrain is flat or undulating individual pumping units (STEP) can be used. In these cases, each connection includes one or more effluent pumps located either in the septic tank or in a separate pump chamber. The septic tank effluent is then pumped into a small diameter force main (2 to 4-inch PVC or HDPE). Grit, grease, and other troublesome solids which might cause obstructions in the pumps or collector mains are separated from the waste flow and retained in septic tanks installed upstream of each connection. With the solids removed, the collector main need not be designed to carry solids, unlike conventional sewers. **Figure D-3** illustrates typical STEP/STEG sewer layout; **Figure D-4** provides details of a typical STEP unit.

Where the terrain and land area favorable, STEP/STEG systems can also be designed in a “cluster” configuration, where small groups of houses have gravity sewers leading to a common septic tank and pumping unit for each “cluster”. The cluster STEP units all discharge into the STEP pressure main, which may also have connections from individual STEP units.

#### Advantages and Disadvantages

##### ***Advantages***

Effluent STEP/STEG sewers have many of the same advantages cited for pressure sewers. An added advantage is the absence of solids in the sewer lines, since the solids are retained in septic tanks. This reduces the stress on pumping facilities and eases the passage of wastewater through the system. The removal of solids from the waste flow also significantly reduces the load on the treatment plant. Because of their smaller size, reduced gradients and lack of manholes, STEP/STEG systems can also have a distinct cost advantage over conventional gravity sewers where adverse conditions create excavation problems or where roadway restoration costs in developed areas can be excessive.

## ***Disadvantages***

STEP/STEG sewers usually are not well suited in high-density developments because of the cost of installing and maintaining the septic tanks. Since sewage is maintained in an anaerobic or septic state in STEP/STEG systems, nuisance gases are produced that may cause odor problems at individual connections. However, the venting of odors is no different from the conditions with individual septic systems; odors are vented through the house plumbing stacks. Another disadvantage of STEP/STEG sewers is the reliance on septic tank pump-outs and disposal of septage. Accumulated digested sludge and scum must be removed from the septic tank and disposed of on a periodic basis (every three to five years, on average). Although this is no different from existing conditions where onsite septic systems used.

The main disadvantage of STEP sewers is the added complexity of the large number of pumps and controls that would have to be installed and maintained at the individual residences. Most modern STEP units are very reliable, have a relatively long service life, and include built-in alarms to alert the homeowner in the event of a pump failure. Nevertheless, the impact during extended power outages can be a concern with STEP sewers depending on the amount of reserve storage capacity provided at the STEP unit and lack of readily available back-up power. STEP units are normally configured to provide emergency storage capacity of about 100 to 200 gallons in the septic tank or a separate pump basin, which should normally be sufficient for a one to two-day power outage. Some sanitary districts require STEP units to be installed with a transfer switch to allow pump operation using a portable generator. Larger commercial or multi-family complexes can be equipped with an automatic backup generator.

Finally, as noted previously under the discussion of pressure sewers, STEP/STEG sewers require easements for maintenance and repair of on-lot facilities along with greater attention to public relations and considerable interaction between the district personnel and property owners.

## **Operation and Maintenance**

Operation and maintenance activities for a STEP/STEG sewer system consist mainly of septic tank pump-outs and maintenance, annual inspection and repair, and cleaning out of individual on-lot pump facilities, as needed. Because STEP collection lines are pressurized and do not transport any solids, solids accumulation and associated cleaning of the sewer lines are not normally required to the same degree as for conventional sewers.

## **5.0 COLLECTION SYSTEM LAYOUTS AND RECOMMENDATIONS**

### **Preliminary Collection System Layouts**

The attached figures show the layout of various collection system options for Woodacre and San Geronimo service areas as follows.

- Figure D-5
- Figure D-6
- Figure D-7

- Figure D-8
- Figure D-9

## Recommendations

Following are recommended methods for sewage collection systems for Woodacre and San Geronimo service areas for different community wastewater system alternatives.

### ***Project Alternative 3 – Fire Road Community Leachfield***

Sewage collection would be provided by a combination of septic tank effluent pump (STEP) and small diameter (4-inch) gravity effluent sewers. This would include the continued use of existing or upgraded on-lot septic tanks, cluster tanks for multiple properties in some cases, and a system of 2-inch to 4-inch diameter pressure piping to bring the septic tank effluent to a central treatment plant location at Park Street.

### ***Water Recycling Alternatives 4 through 6***

**Woodacre.** The recommended sewage collection method for Woodacre is a conventional gravity system for most of the area, with a main lift station located at the northeast corner of Railroad Avenue and San Geronimo Valley Drive, and a force main from the lift station to the treatment plant at San Geronimo Golf Course. The force main would follow one of two alternative routes: (a) via San Geronimo Valley Drive to the west entrance to the Golf Course maintenance yard; or (b) via Railroad Avenue and Sir Francis Drake Boulevard. Because of the undulating terrain, a pressure sewer would be used for properties along Redwood Drive, tying in at the main lift station. The pressure sewer would eliminate the need for deep sewer construction and/or multiple lift stations that would be needed for a gravity sewer line in this area. The properties along the Redwood Avenue pressure sewer branch would all have individual on-lot grinder pumps.

**San Geronimo.** The recommended sewage collection method for San Geronimo is a pressure sewer system. The pressure sewer network would consist of 2-inch, 3-inch and 4-inch diameter pipes, running west-to-east on Sir Francis Drake Blvd, San Geronimo Valley Dr. and Meadow Way, eventually connecting together at San Geronimo Valley Drive before entering the golf course and following the maintenance road to the proposed wastewater treatment plant. Due to the flat and undulating terrain, which slopes steadily downstream, away from the golf course, analysis shows that gravity sewers would be a significantly more expensive option for San Geronimo, requiring deep trenching and multiple lift stations in the community.

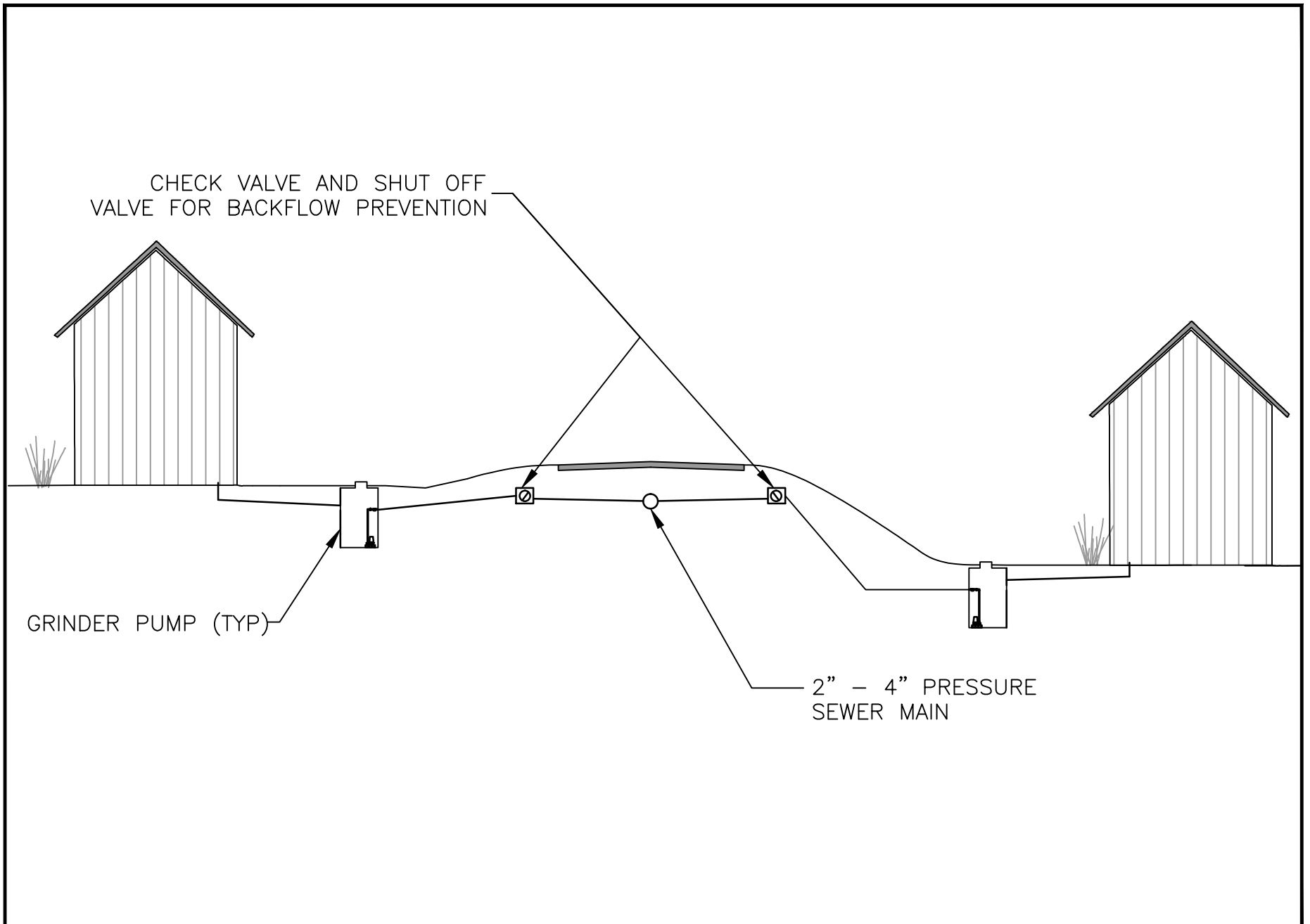

Date:	2/27/17
Drawn:	AM/MF
Appr'd:	NH
Dwg. No:	1600073/CAD/MODEL

  
**QUESTA**

*Civil  
Environmental  
& Water Resources*

**ENGINEERING CORP.**

(510) 236-6114  
 FAX (510) 236-2423  
 .questa@questaec.com  
 P.O. Box 70356 1220 Brickyard Cove Road Point Richmond, CA 94807

**TYPICAL PRESSURE SEWER**

**WOODACRE/SAN GERONIMO  
WASTEWATER FEASIBILITY STUDY**

**FIGURE  
D-1**



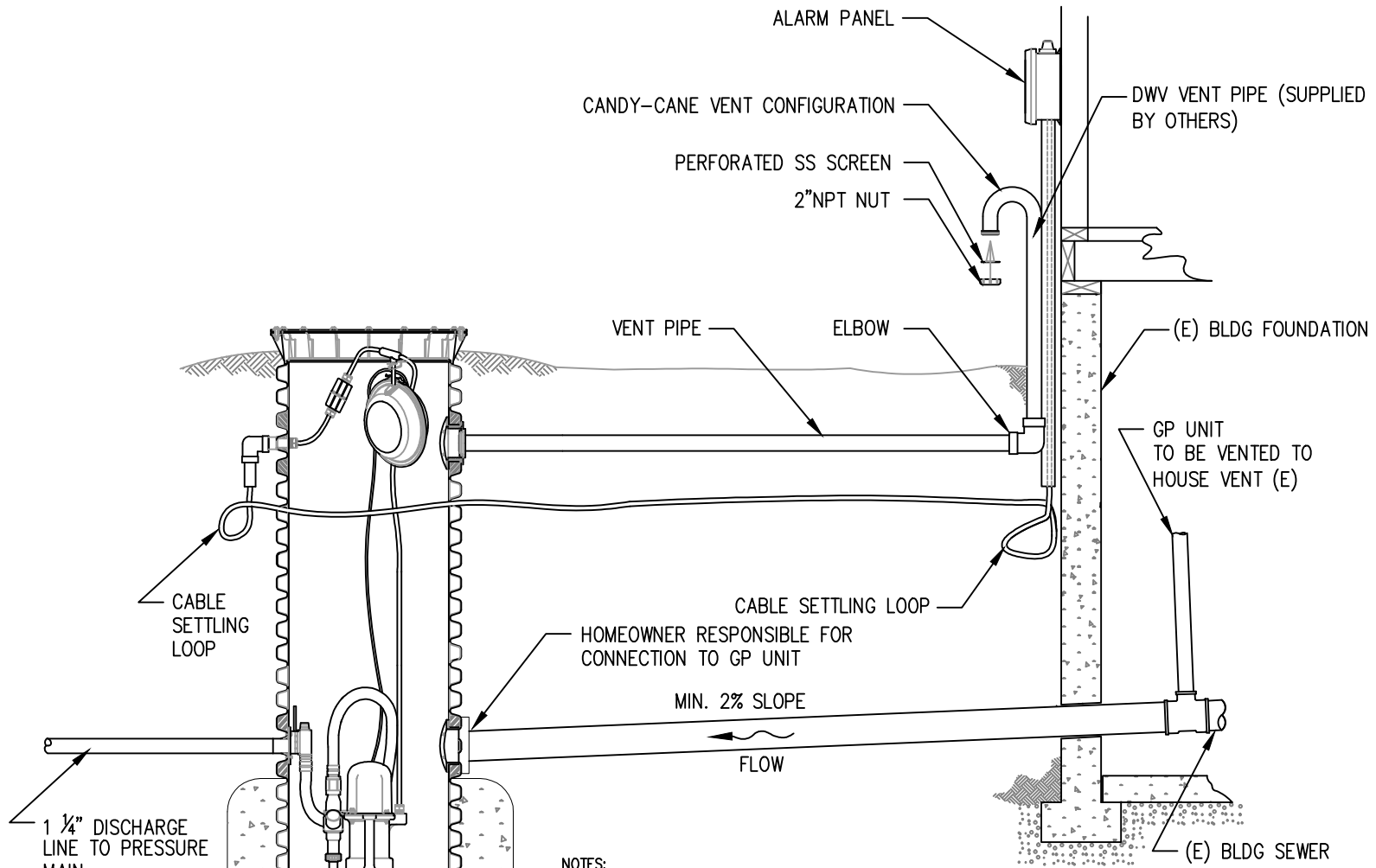

**NOTES:**

1. CONTRACTOR TO INSTALL GRINDER PUMPS ACCORDING TO MANUFACTURER'S REQUIREMENTS.
2. CONTRACTOR TO PROVIDE INLET, CAPPED AND FIELD MARKED.
3. HOMEOWNER SHALL CONNECT (E) SEWER TO INLET, WITH MIN. 2% SLOPE.
4. GRINDER PUMP UNIT WILL VENT THRU (E) PLUMBING VENT.
5. IF (E) PLUMBING VENTILATION IS NOT PER 1997 UPC, CONTRACTOR SHALL CONNECT OPTIONAL 2" VENT PIPE TO EXTERIOR OF BUILDING.

Date: 2/27/17  
 Drawn: AM/MF  
 Appr'd: NH  
 Dwg. No: 1600073/CAD/MODEL

**QUESTA**  
 Civil Environmental & Water Resources  
 ENGINEERING CORP

(510) 236-6114  
 FAX (510) 236-2423  
 -questa@questaec.com  
 P.O. Box 70356 1220 Brickyard Cove Road Point Richmond, CA 94807

**TYPICAL GRINDER PUMP UNIT**  
  
**WOODACRE/SAN GERONIMO  
 WASTEWATER FEASIBILITY STUDY**

**FIGURE  
 D-2**

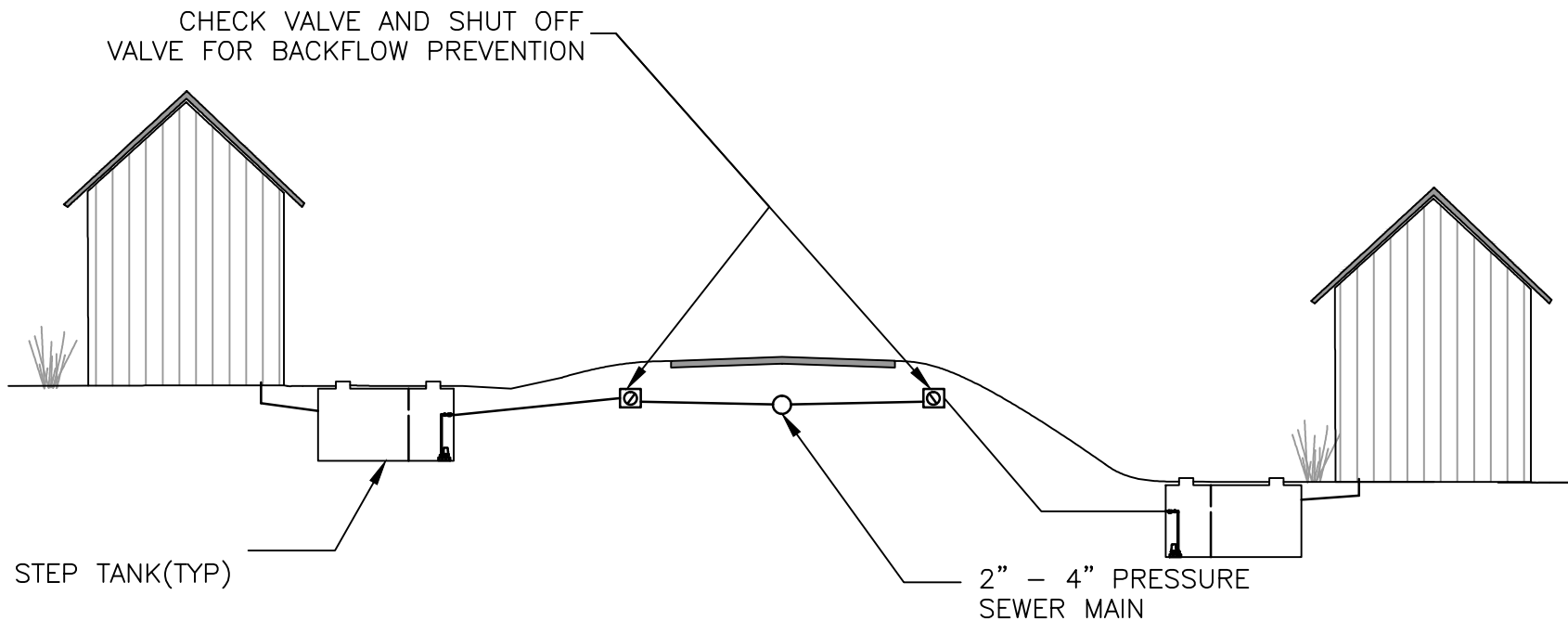

Date: 2/27/17  
 Drawn: AM/MF  
 Appr'd: NH  
 Dwg. No: 1600073/CAD/MODEL

**QUESTA** *Civil Environmental & Water Resources*

ENGINEERING CORP. (510) 236-6114 FAX (510) 236-2423 .questa@questaec.com  
 P.O. Box 70356 1220 Brickyard Cove Road Point Richmond, CA 94807

**TYPICAL STEP SYSTEM**

**WOODACRE/SAN GERONIMO  
 WASTEWATER FEASIBILITY STUDY**

**FIGURE  
 D-3**

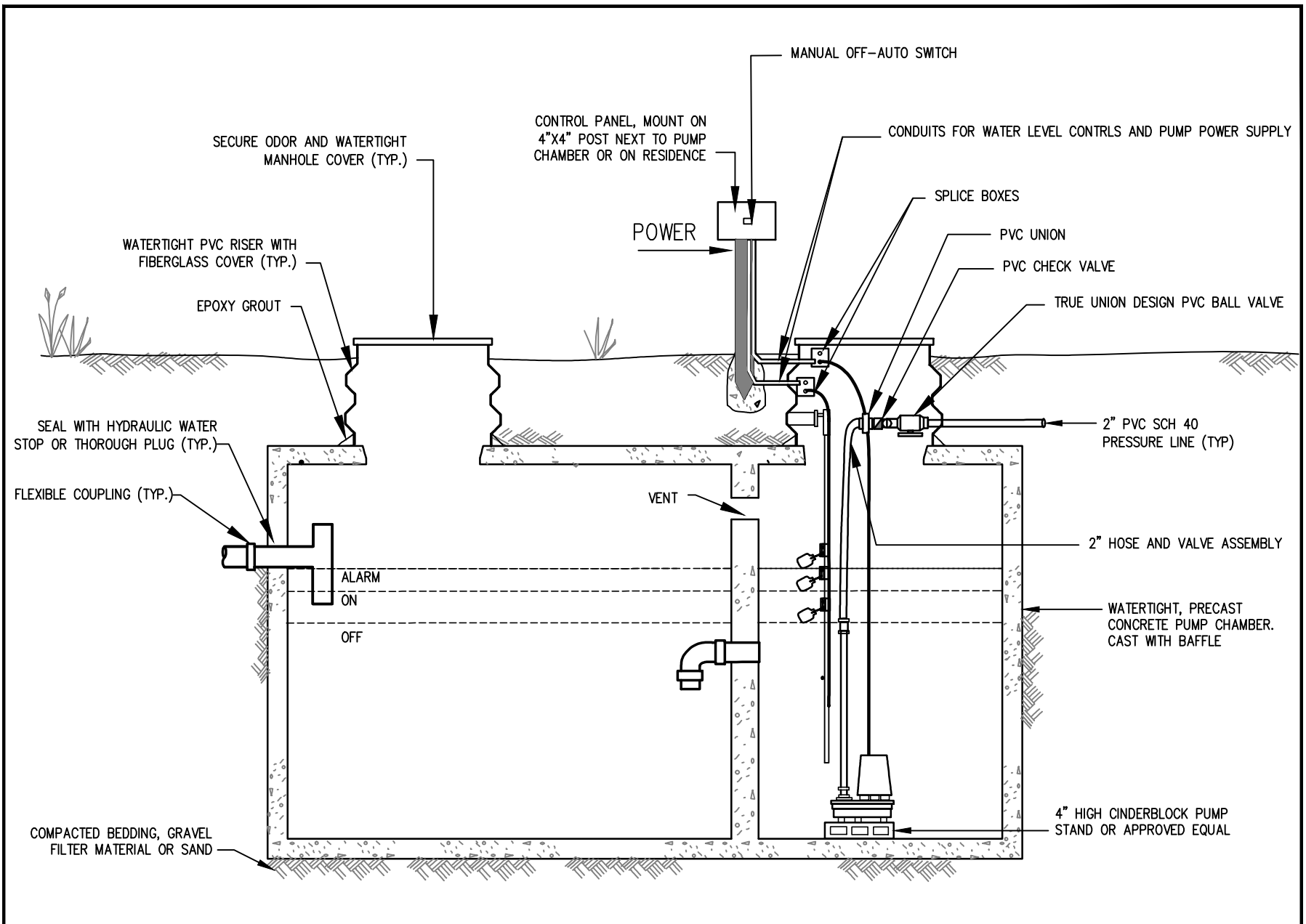

Date:	2/27/17
Drawn:	AM/MF
Appr'd:	NH
Dwg. No:	1600073/CAD/MODEL

  
**QUESTA**
  
*Civil Environmental & Water Resources*
  
 ENGINEERING CORP.

(510) 236-6114  
 FAX (510) 236-2423  
 • [questa@questaec.com](mailto:questa@questaec.com)  
 P.O. Box 70356 1220 Brickyard Cove Road Point Richmond, CA 94807

**TYPICAL SEPTIC TANK WITH  
 EFFLUENT PUMP (STEP)  
 WOODACRE/SAN GERONIMO  
 WASTEWATER FEASIBILITY STUDY**

**FIGURE  
 D-4**

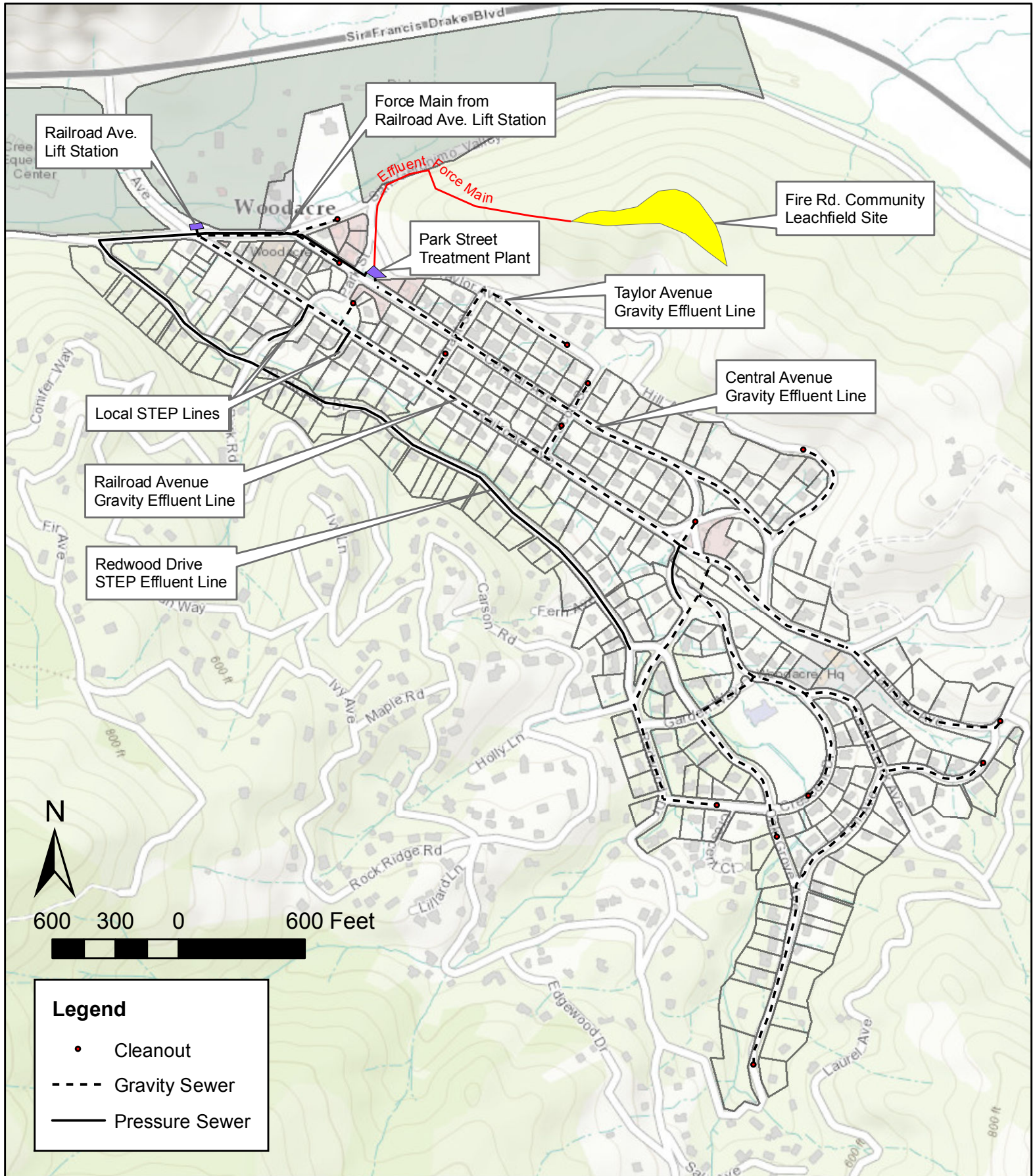

DATE: 2/28/2017  
 PROJECT: WOODACRE WW  
 PROJECT NO.: 1600073  
 DRAWN: DD/MF  
 APPROVED: NH



**FIRE ROAD LEACHFIELD  
 ALTERNATIVE  
 EFFLUENT STEP/STEP  
 SYSTEM**

**FIGURE  
 D-5**

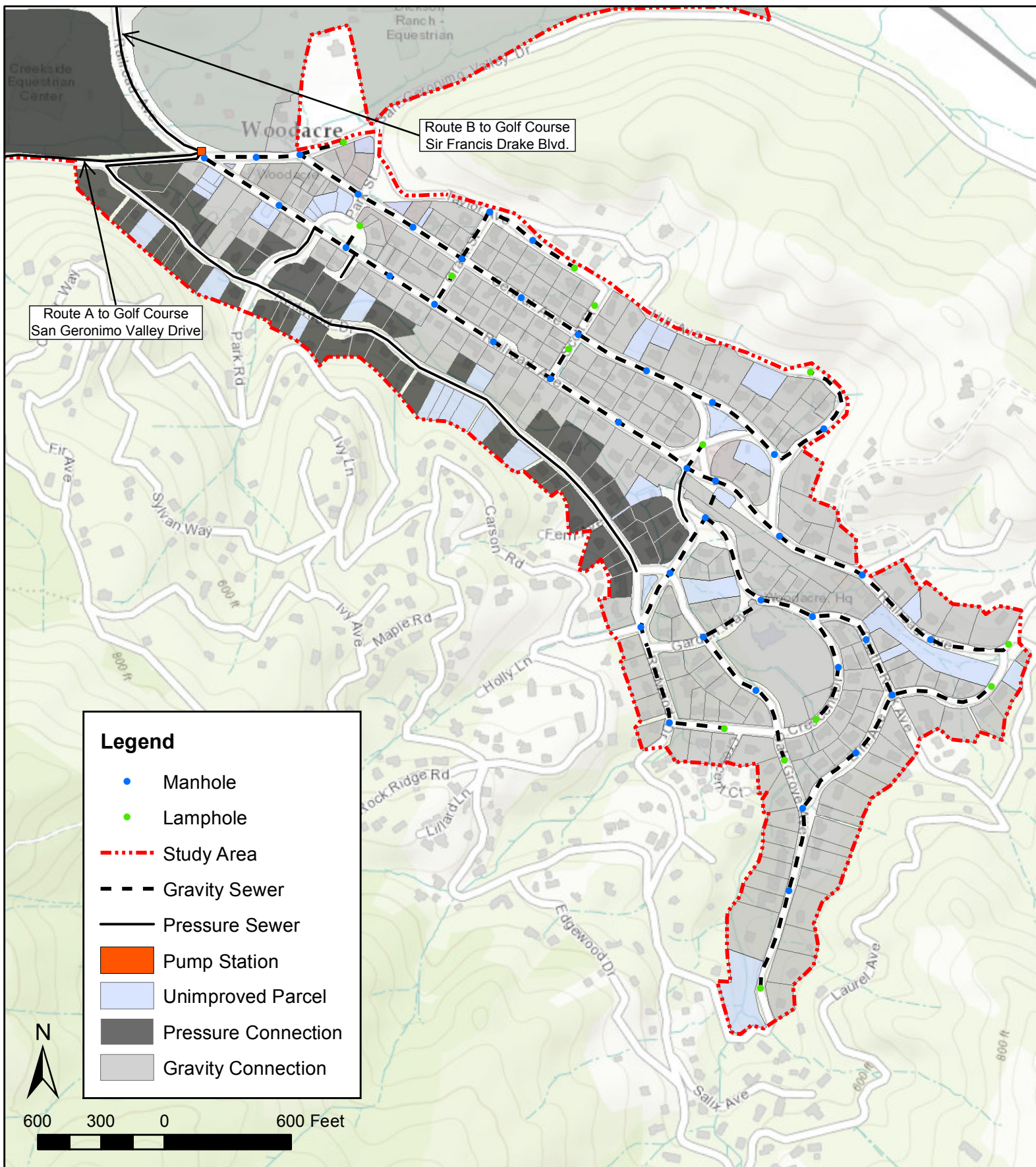

DATE: 12/20/2016  
 PROJECT: WOODACRE WW  
 PROJECT NO.: 1600073  
 DRAWN: DD  
 APPROVED: NH



**WOODACRE  
 GRAVITY SEWER  
 SYSTEM PLAN**

**FIGURE  
 D-6**

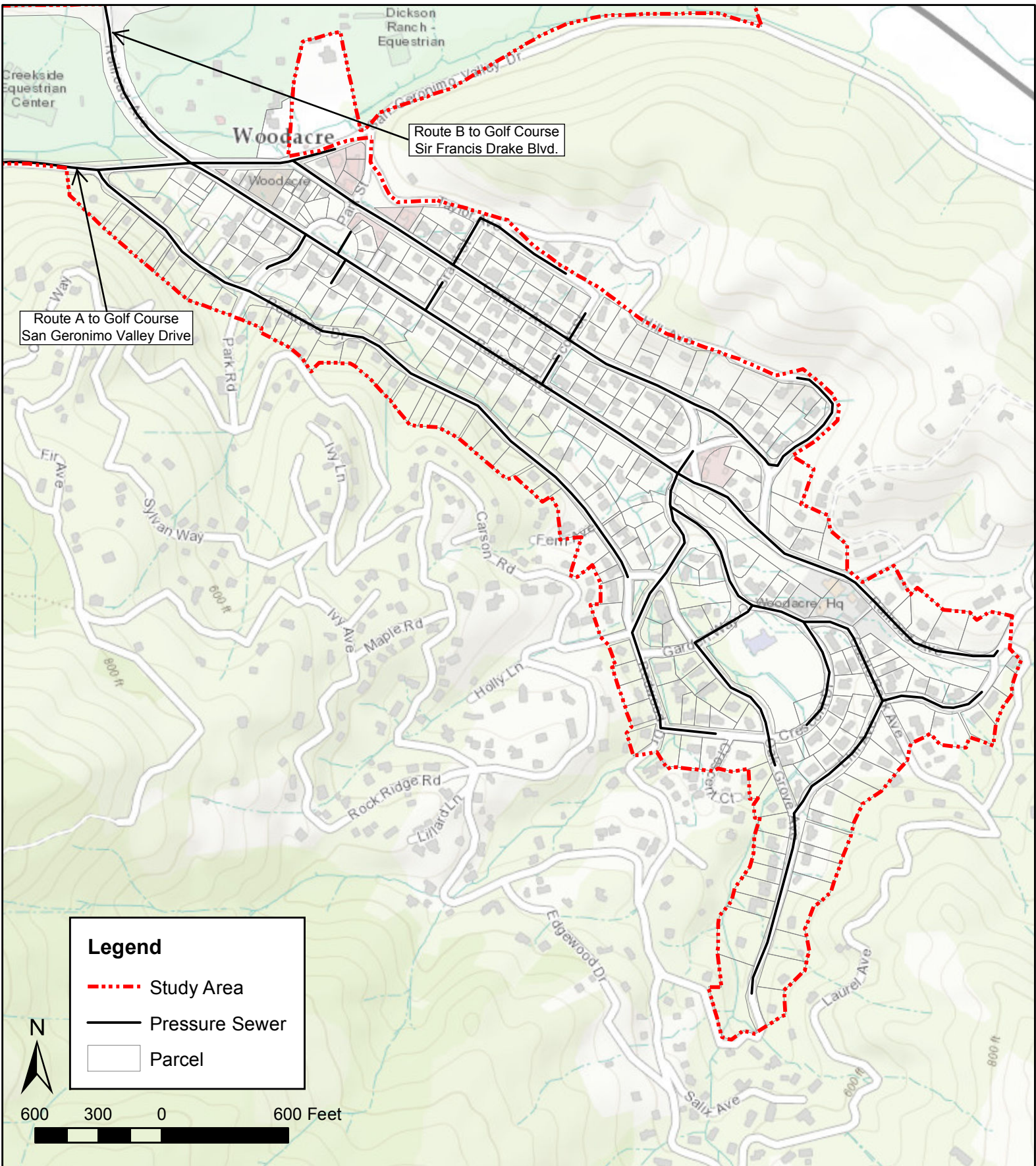

DATE: 12/20/2016  
 PROJECT: WOODACRE WW  
 PROJECT NO.: 1600073  
 DRAWN: DD  
 APPROVED: NH



**WOODACRE  
 PRESSURE SEWER  
 SYSTEM PLAN**

**FIGURE  
 D-7**

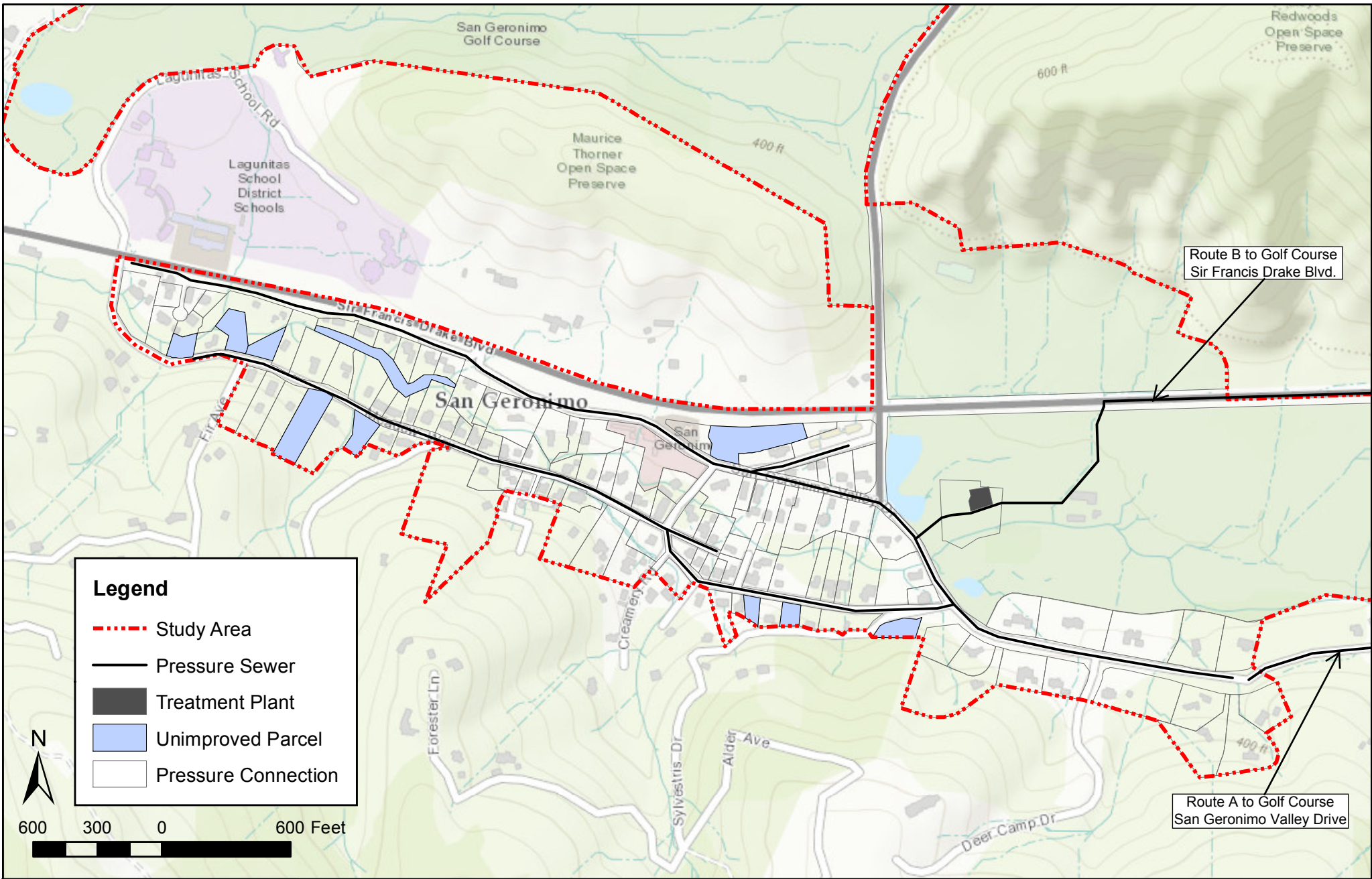

**Legend**

- - - Study Area
- Pressure Sewer
- Treatment Plant
- Unimproved Parcel
- Pressure Connection

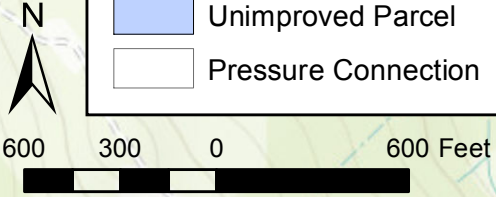

DATE:	12/20/2016
PROJECT:	WOODACRE WW
PROJECT NO.:	1600073
DRAWN:	DD
APPROVED:	NH



**SAN GERONIMO  
PRESSURE SEWER  
SYSTEM PLAN**

**FIGURE  
D-8**

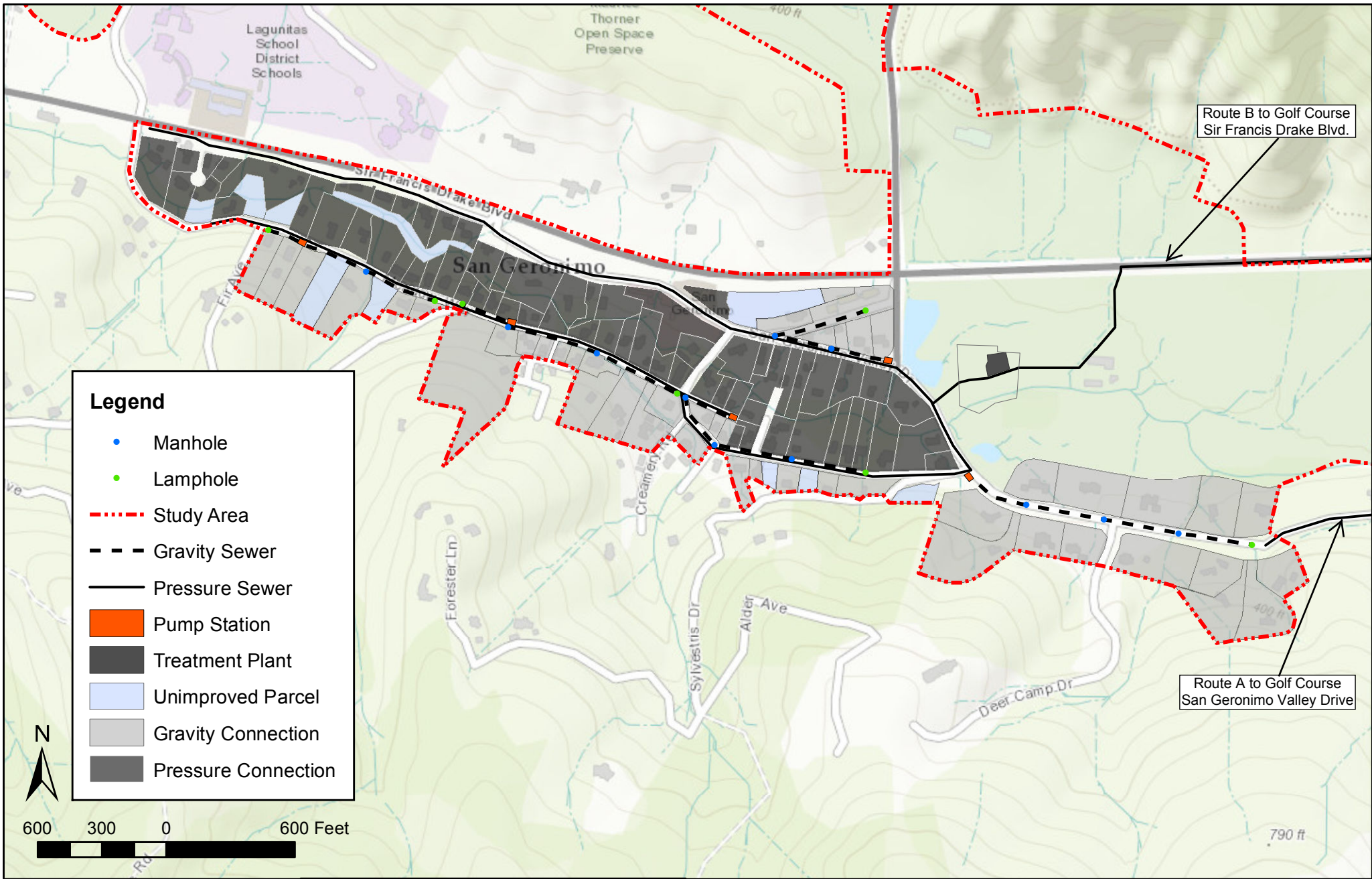

**Legend**

- Manhole
- Lamphole
- - - Study Area
- - - Gravity Sewer
- Pressure Sewer
- Pump Station
- Treatment Plant
- Unimproved Parcel
- Gravity Connection
- Pressure Connection

DATE:	12/20/2016
PROJECT:	WOODACRE WW
PROJECT NO.:	1600073
DRAWN:	DD
APPROVED:	NH



**SAN GERONIMO  
CLUSTER SEWER  
SYSTEM PLAN**

**FIGURE  
D-9**



Appendix E

---

# Wastewater Treatment Literature



# Wastewater Management Fact Sheet

## Membrane Bioreactors

### INTRODUCTION

The technologies most commonly used for performing secondary treatment of municipal wastewater rely on microorganisms suspended in the wastewater to treat it. Although these technologies work well in many situations, they have several drawbacks, including the difficulty of growing the right types of microorganisms and the physical requirement of a large site. The use of microfiltration membrane bioreactors (MBRs), a technology that has become increasingly used in the past 10 years, overcomes many of the limitations of conventional systems. These systems have the advantage of combining a suspended growth biological reactor with solids removal via filtration. The membranes can be designed for and operated in small spaces and with high removal efficiency of contaminants such as nitrogen, phosphorus, bacteria, biochemical oxygen demand, and total suspended solids. The membrane filtration system in effect can replace the secondary clarifier and sand filters in a typical activated sludge treatment system. Membrane filtration allows a higher biomass concentration to be maintained, thereby allowing smaller bioreactors to be used.

### APPLICABILITY

For new installations, the use of MBR systems allows for higher wastewater flow or improved treatment performance in a smaller space than a conventional design, i.e., a facility using secondary clarifiers and sand filters. Historically, membranes have been used for smaller-flow systems due to the high capital cost of the equipment and high operation and maintenance (O&M) costs. Today however, they are receiving increased use in larger systems. MBR systems are also well suited for some industrial and commercial applications. The high-quality effluent produced by MBRs makes them particularly applicable to reuse applications and for surface

water discharge applications requiring extensive nutrient (nitrogen and phosphorus) removal.

### ADVANTAGES AND DISADVANTAGES

The advantages of MBR systems over conventional biological systems include better effluent quality, smaller space requirements, and ease of automation. Specifically, MBRs operate at higher volumetric loading rates which result in lower hydraulic retention times. The low retention times mean that less space is required compared to a conventional system. MBRs have often been operated with longer solids residence times (SRTs), which results in lower sludge production; but this is not a requirement, and more conventional SRTs have been used (Crawford et al. 2000). The effluent from MBRs contains low concentrations of bacteria, total suspended solids (TSS), biochemical oxygen demand (BOD), and phosphorus. This facilitates high-level disinfection. Effluents are readily discharged to surface streams or can be sold for reuse, such as irrigation.

The primary disadvantage of MBR systems is the typically higher capital and operating costs than conventional systems for the same throughput. O&M costs include membrane cleaning and fouling control, and eventual membrane replacement. Energy costs are also higher because of the need for air scouring to control bacterial growth on the membranes. In addition, the waste sludge from such a system might have a low settling rate, resulting in the need for chemicals to produce biosolids acceptable for disposal (Hermanowicz et al. 2006). Fleischer et al. 2005 have demonstrated that waste sludges from MBRs can be processed using standard technologies used for activated sludge processes.

## MEMBRANE FILTRATION

Membrane filtration involves the flow of water-containing pollutants across a membrane. Water permeates through the membrane into a separate channel for recovery (Figure 1). Because of the cross-flow movement of water and the waste constituents, materials left behind do not accumulate at the membrane surface but are carried out of the system for later recovery or disposal. The water passing through the membrane is called the *permeate*, while the water with the more-concentrated materials is called the *concentrate* or *retentate*.

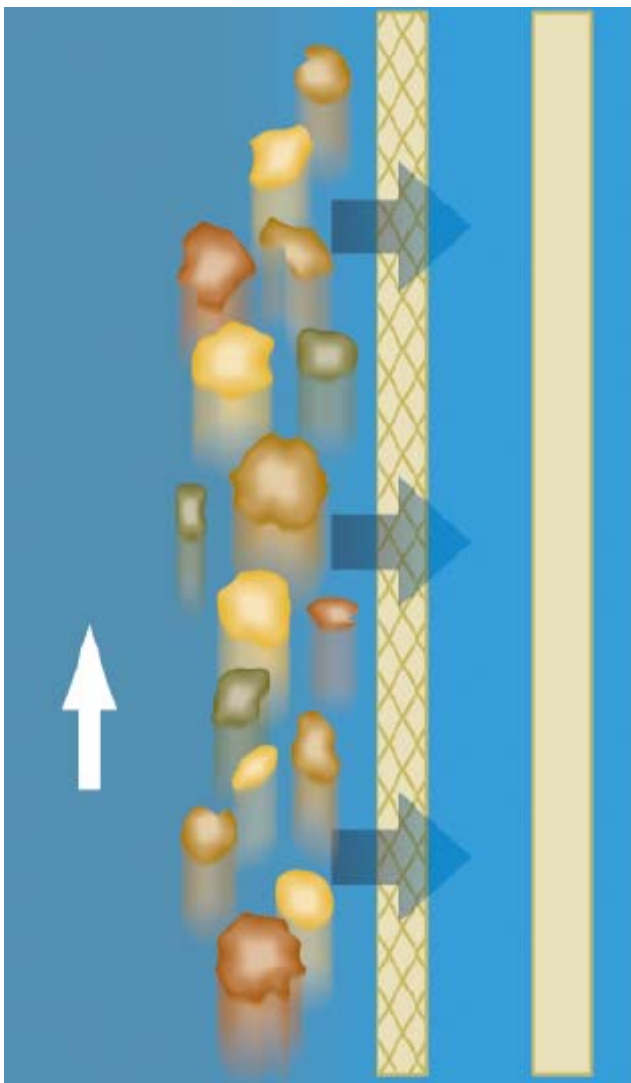

**Figure 1. Membrane filtration process (Image from Siemens/U.S. Filter)**

Membranes are constructed of cellulose or other polymer material, with a maximum pore size set during the manufacturing process. The require-

ment is that the membranes prevent passage of particles the size of microorganisms, or about 1 micron (0.001 millimeters), so that they remain in the system. This means that MBR systems are good for removing solid material, but the removal of dissolved wastewater components must be facilitated by using additional treatment steps.

Membranes can be configured in a number of ways. For MBR applications, the two configurations most often used are hollow fibers grouped in bundles, as shown in Figure 2, or as flat plates. The hollow fiber bundles are connected by manifolds in units that are designed for easy changing and servicing.



**Figure 2. Hollow-fiber membranes (Image from GE/Zenon)**

## DESIGN CONSIDERATIONS

Designers of MBR systems require only basic information about the wastewater characteristics, (e.g., influent characteristics, effluent requirements, flow data) to design an MBR system. Depending on effluent requirements, certain supplementary options can be included with the MBR system. For example, chemical addition (at various places in the treatment chain, including: before the primary settling tank; before the secondary settling tank [clarifier]; and before the MBR or final filters) for phosphorus removal can be included in an MBR system if needed to achieve low phosphorus concentrations in the effluent.

MBR systems historically have been used for small-scale treatment applications when portions of the treatment system were shut down and the

wastewater routed around (or bypassed) during maintenance periods.

However, MBR systems are now often used in full-treatment applications. In these instances, it is recommended that the installation include one additional membrane tank/unit beyond what the design would nominally call for. This “N plus 1” concept is a blend between conventional activated sludge and membrane process design. It is especially important to consider both operations and maintenance requirements when selecting the number of units for MBRs. The inclusion of an extra unit gives operators flexibility and ensures that sufficient operating capacity will be available (Wallis-Lage et al. 2006). For example, bioreactor sizing is often limited by oxygen transfer, rather than the volume required to achieve the required SRT—a factor that significantly affects bioreactor numbers and sizing (Crawford et al. 2000).

Although MBR systems provide operational flexibility with respect to flow rates, as well as the ability to readily add or subtract units as conditions dictate, that flexibility has limits. Membranes typically require that the water surface be maintained above a minimum elevation so that the membranes remain wet during operation. Throughput limitations are dictated by the physical properties of the membrane, and the result is that peak design flows should be no

more than 1.5 to 2 times the average design flow. If peak flows exceed that limit, either additional membranes are needed simply to process the peak flow, or equalization should be included in the overall design. The equalization is done by including a separate basin (external equalization) or by maintaining water in the aeration and membrane tanks at depths higher than those required and then removing that water to accommodate higher flows when necessary (internal equalization).

## DESIGN FEATURES

### Pretreatment

To reduce the chances of membrane damage, wastewater should undergo a high level of debris removal prior to the MBR. Primary treatment is often provided in larger installations, although not in most small to medium sized installations, and is not a requirement. In addition, all MBR systems require 1- to 3-mm-cutoff fine screens immediately before the membranes, depending on the MBR manufacturer. These screens require frequent cleaning. Alternatives for reducing the amount of material reaching the screens include using two stages of screening and locating the screens after primary settling.

### Membrane Location

MBR systems are configured with the mem-

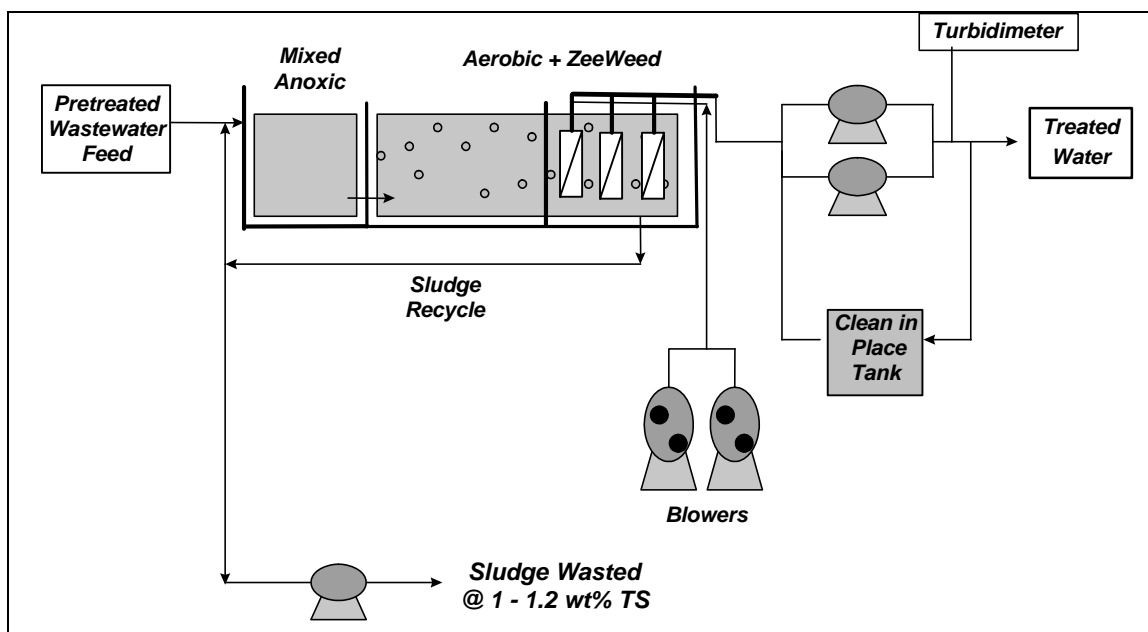
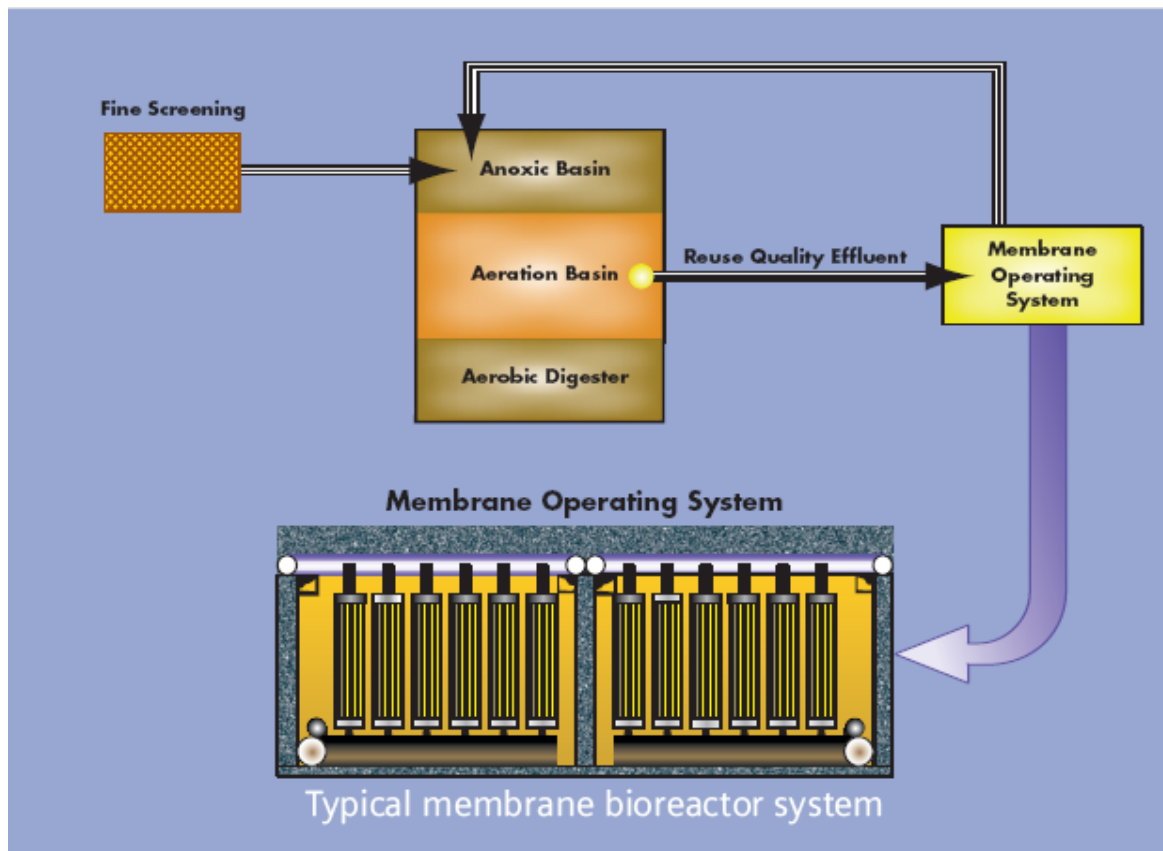

Figure 3. Immersed membrane system configuration (Image from GE/Zenon)



**Figure 4. External membrane system configuration (Image from Siemens/U.S. Filter)**

branes actually immersed in the biological reactor or, as an alternative, in a separate vessel through which mixed liquor from the biological reactor is circulated. The former configuration is shown in Figure 3; the latter, in Figure 4.

### Membrane Configuration

MBR manufacturers employ membranes in two basic configurations: hollow fiber bundles and plate membranes. Siemens/U.S.Filter's Memjet and Memcor systems, GE/Zenon's ZeeWeed and ZenoGem systems, and GE/Ionics' system use hollow-fiber, tubular membranes configured in bundles. A number of bundles are connected by manifolds into units that can be readily changed for maintenance or replacement. The other configuration, such as those provided by Kubota/Enviroquip, employ membranes in a flat-plate configuration, again with manifolds to allow a number of membranes to be connected in readily changed units. Screening requirements for both systems differ: hollow-fiber membranes typically require 1- to 2-mm screening, while

plate membranes require 2- to 3-mm screening (Wallis-Lage et al. 2006).

### System Operation

All MBR systems require some degree of pumping to force the water flowing through the membrane. While other membrane systems use a pressurized system to push the water through the membranes, the major systems used in MBRs draw a vacuum through the membranes so that the water outside is at ambient pressure. The advantage of the vacuum is that it is gentler to the membranes; the advantage of the pressure is that throughput can be controlled. All systems also include techniques for continually cleaning the system to maintain membrane life and keep the system operational for as long as possible. All the principal membrane systems used in MBRs use an air scour technique to reduce buildup of material on the membranes. This is done by blowing air around the membranes out of the manifolds. The GE/Zenon systems use air scour, as well as a back-pulsing technique, in which permeate is occasionally pumped back

into the membranes to keep the pores cleared out. Back-pulsing is typically done on a timer, with the time of pulsing accounting for 1 to 5 percent of the total operating time.

### **Downstream Treatment**

The permeate from an MBR has low levels of suspended solids, meaning the levels of bacteria, BOD, nitrogen, and phosphorus are also low. Disinfection is easy and might not be required, depending on permit requirements..

The solids retained by the membrane are recycled to the biological reactor and build up in the system. As in conventional biological systems, periodic sludge wasting eliminates sludge buildup and controls the SRT within the MBR system. The waste sludge from MBRs goes through standard solids-handling technologies for thickening, dewatering, and ultimate disposal. Hermanowicz et al. (2006) reported a decreased ability to settle in waste MBR sludges due to increased amounts of colloidal-size particles and filamentous bacteria. Chemical addition increased the ability of the sludges to settle. As more MBR facilities are built and operated, a more definitive understanding of the characteristics of the resulting biosolids will be achieved. However, experience to date indicates that conventional biosolids processing unit operations are also applicable to the waste sludge from MBRs.

### **Membrane Care**

The key to the cost-effectiveness of an MBR system is membrane life. If membrane life is curtailed such that frequent replacement is required, costs will significantly increase. Membrane life can be increased in the following ways:

- Good screening of larger solids before the membranes to protect the membranes from physical damage.
- Throughput rates that are not excessive, i.e., that do not push the system to the limits of the design. Such rates reduce the amount of material that is forced into the membrane and thereby reduce the amount that has to be re-

moved by cleaners or that will cause eventual membrane deterioration.

- Regular use of mild cleaners. Cleaning solutions most often used with MBRs include regular bleach (sodium) and citric acid. The cleaning should be in accord with manufacturer-recommended maintenance protocols.

### **Membrane Guarantees**

The length of the guarantee provided by the membrane system provider is also important in determining the cost-effectiveness of the system. For municipal wastewater treatment, longer guarantees might be more readily available compared to those available for industrial systems. Zenon offers a 10-year guarantee; others range from 3 to 5 years. Some guarantees include cost prorating if replacement is needed after a certain service time. Guarantees are typically negotiated during the purchasing process. Some manufacturers' guarantees are tied directly to screen size: longer membrane warranties are granted when smaller screens are used (Wallis-Lage et al. 2006). Appropriate membrane life guarantees can be secured using appropriate membrane procurement strategies (Crawford et al. 2002).

## **SYSTEM PERFORMANCE**

### **Siemens/U.S. Filter Systems**

Siemens/U.S.Filter offers MBR systems under the Memcor and Memjet brands. Data provided by U.S. Filter for its Calls Creek (Georgia) facility are summarized below. The system, as Calls Creek retrofitted it, is shown in Figure 5. In essence, the membrane filters were used to replace secondary clarifiers downstream of an Orbal oxidation ditch. The system includes a fine screen (2-mm cutoff) for inert solids removal just before the membranes.

The facility has an average flow of 0.35 million gallons per day (mgd) and a design flow of 0.67 mgd. The system has 2 modules, each containing 400 units, and each unit consists of a cassette with manifold-connected membranes. As shown in Table 1, removal of BOD, TSS, and ammonia-nitrogen is excellent; BOD and TSS in the effluent are around the detection limit. Phosphorus is also removed well in the system, and the effluent

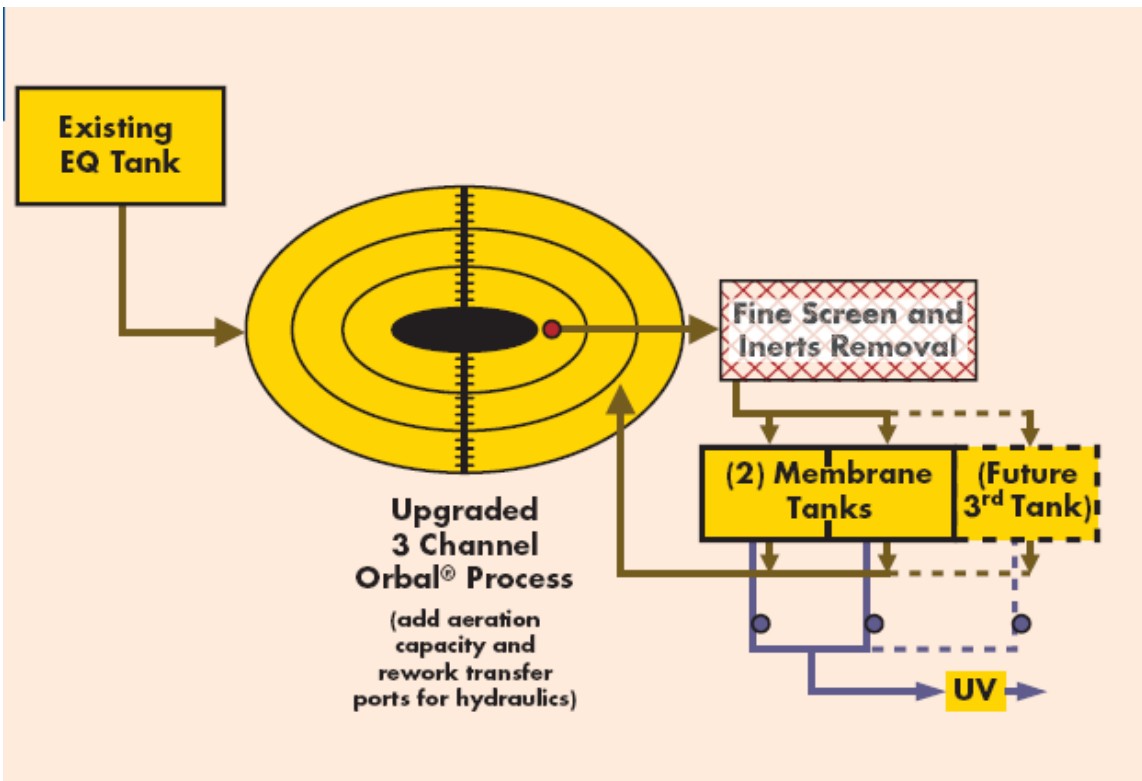

Figure 5. Calls Creek flow diagram (courtesy of Siemens/U.S. Filter)

Table 1.  
Calls Creek results 2005

Parameter	Influent	Effluent		
	Average	Average	Max Month	Min Month
Flow (mgd)	0.35	--	0.44	0.26
BOD (mg/L)	145	1	1	1
TSS (mg/L)	248	1	1	1
Ammonia-N (mg/L)	14.8	0.21	0.72	0.10
P (mg/L)	0.88	0.28	0.55	0.12
Fecal coliforms (#/100 mL)	--	14.2	20	0
Turbidity (NTU)	--	0.30	1.31	0.01

has very low turbidity. The effluent has consistently met discharge limits.

### Zenon Systems

General Electric/Zenon provides systems under the ZenoGem and ZeeWeed brands. The ZeeWeed brand refers to the membrane, while ZenoGem is the process that uses ZeeWeed.

Performance data for two installed systems are shown below.

**Cauley Creek, Georgia.** The Cauley Creek facility in Fulton County, Georgia, is a 5-mgd wastewater reclamation plant. The system includes biological phosphorus removal, mixed liquor surface wasting, and sludge thickening using a ZeeWeed system to minimize the required volume of the aerobic digester, according to information provided by GE. Ultraviolet disinfection is employed to meet regulatory limits. Table 2 shows that the removal for all parame-

**Table 2.**  
**Cauley Creek, Georgia, system performance**

Parameter	Influent Average	Effluent		
		Average	Max Month	Min Month
Flow (mgd)	4.27	--	4.66	3.72
BOD (mg/L)	182	2.0	2.0	2.0
COD (mg/L)	398	12	22	5
TSS (mg/L)	174	3.2	5	3
TKN (mg/L)	33.0	1.9	2.9	1.4
Ammonia-N (mg/L)	24.8	0.21	0.29	0.10
TP (mg/L)	5.0	0.1	0.13	0.06
Fecal coliforms (#/100 mL)	--	2	2	2
NO3-N (mg/L)	--	2.8		

ters is over 90 percent. The effluent meets all permit limits, and is reused for irrigation and lawn watering.

**Traverse City, Michigan.** The Traverse City Wastewater Treatment Plant (WWTP) went through an upgrade to increase plant capacity and produce a higher-quality effluent, all within the facility's existing plant footprint (Crawford et al. 2005). With the ZeeWeed system, the facility was able to achieve those goals. As of 2006, the plant is the largest-capacity MBR facility in North America. It has a design average annual flow of 7.1 mgd, maximum monthly flow of 8.5 mgd, and peak hourly flow of 17 mgd. The membrane system consists of a 450,000-gallon tank with eight compartments of equal size. Secondary sludge is distributed evenly to the compartments. Blowers for air scouring, as well as permeate and back-pulse pumps, are housed in a nearby building.

Table 3 presents a summary of plant results over a 12-month period. The facility provides excellent removal of BOD, TSS, ammonia-nitrogen, and phosphorus. Figure 6 shows the influent, effluent, and flow data for the year.

Operating data for the Traverse City WWTP were obtained for the same period. The mixed liquor suspended solids over the period January to August averaged 6,400 mg/L, while the mixed liquor volatile suspended solids averaged 4,400 mg/L. The energy use for the air-scouring blow-

ers averaged 1,800 kW-hr/million gallons (MG) treated.

## **COSTS**

### **Capital Costs**

Capital costs for MBR systems historically have tended to be higher than those for conventional systems with comparable throughput because of the initial costs of the membranes. In certain situations, however, including retrofits, MBR systems can have lower or competitive capital costs compared with alternatives because MBRs have lower land requirements and use smaller tanks, which can reduce the costs for concrete. U.S. Filter/Siemens Memcor package plants have installed costs of \$7–\$20/gallon treated.

Fleischer et al. (2005) reported on a cost comparison of technologies for a 12-MGD design in Loudoun County, Virginia. Because of a chemical oxygen demand limit, activated carbon adsorption was included with the MBR system. It was found that the capital cost for MBR plus granular activated carbon at \$12/gallon treated was on the same order of magnitude as alternative processes, including multiple-point alum addition, high lime treatment, and post-secondary membrane filtration.

### **Operating Costs**

Operating costs for MBR systems are typically higher than those for comparable conventional systems. This is because of the higher energy



**Table 3.**  
**Summary of Traverse City, Michigan, Performance Results**

Parameter	Influent	Effluent		
	Average	Average	Max Month	Min Month
Flow (mgd)	4.3	--	5.1	3.6
BOD (mg/L)	280	< 2	< 2	< 2
TSS (mg/L)	248	< 1	< 1	< 1
Ammonia-N (mg/L)	27.9	< 0.08	< 0.23	< 0.03
TP (mg/L)	6.9	0.7	0.95	0.41
Temperature (deg C)	17.2	--	23.5	11.5

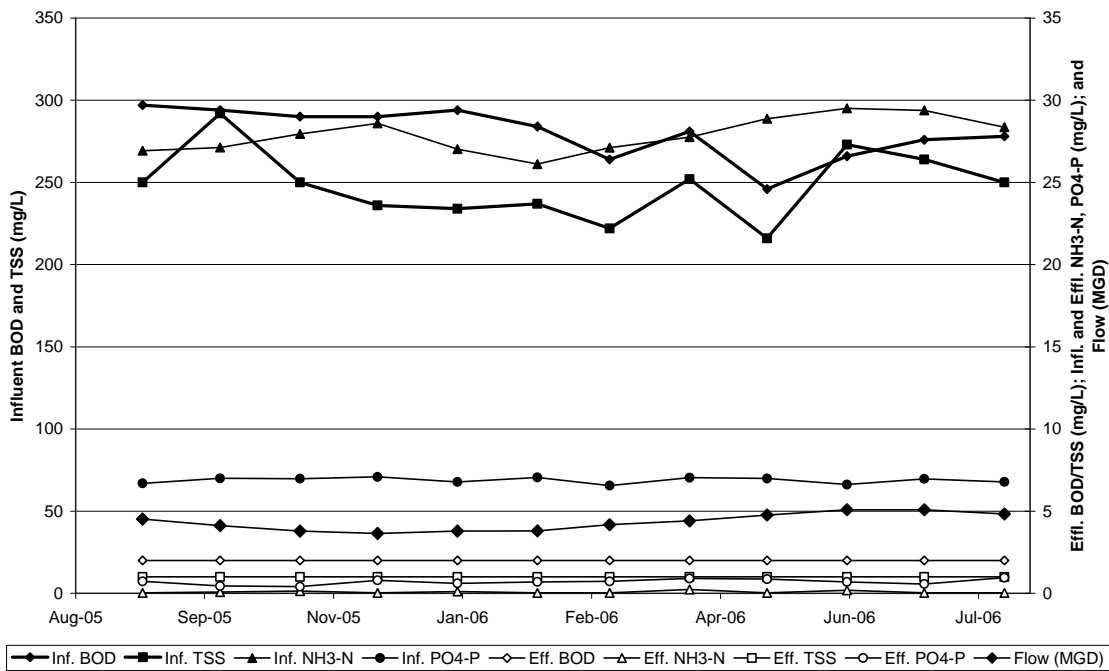

**Figure 6. Performance of the Traverse City plant**

costs if air scouring is used to reduce membrane fouling. The amount of air needed for the scouring has been reported to be twice that needed to maintain aeration in a conventional activated sludge system (Scott Blair, personal communication, 2006). These higher operating costs are often partially offset by the lower costs for sludge disposal associated with running at longer sludge residence times and with membrane thickening/dewatering of wasted sludge.

Fleischer et al. (2005) compared operating costs. They estimated the operating costs of an MBR system including activated carbon adsorption at \$1.77 per 1,000 gallons treated. These costs were

of the same order of magnitude as those of alternative processes, and they compared favorably to those of processes that are chemical-intensive, such as lime treatment.

**ACKNOWLEDGMENTS**

The authors acknowledge Dr. Venkat Mahendrakar, GE/Zenon, Mr. John Irwin, Siemens/U.S. Filter, and Mr. Scott Blair and Mr. Leroy Bonkoski of the Traverse City WWTP for their assistance in obtaining data and system information. EPA acknowledges external peer

reviewers Pat Brooks, Alan Cooper, and Glenn Daigger for their contribution.

## PRODUCT LITERATURE USED

Enviroquip/Kubota. Sales literature.

Siemens. Product literature.

<[http://www.usfilter.com/en/Product+Lines/Envirex\\_Products/Envirex\\_Products/envirex\\_mbr\\_xpress\\_packaged\\_plant.htm](http://www.usfilter.com/en/Product+Lines/Envirex_Products/Envirex_Products/envirex_mbr_xpress_packaged_plant.htm)>.

Zenon. Case studies: Cauley Creek, Georgia.

<[http://www.zenon.com/resources/case\\_studies/water\\_reuse/CauleyCreek.shtml](http://www.zenon.com/resources/case_studies/water_reuse/CauleyCreek.shtml)>.

Zenon. Case studies: Traverse City, Michigan.

<[http://www.zenon.com/resources/case\\_studies/wastewater/TraverseCity.shtml](http://www.zenon.com/resources/case_studies/wastewater/TraverseCity.shtml)>.

## REFERENCES

Crawford, G., G. Daigger, J. Fisher, S. Blair, and R. Lewis. 2005. Parallel Operation of Large Membrane Bioreactors at Traverse City. In *Proceedings of the Water Environment Federation 78th Annual Conference & Exposition*, Washington, DC, CD-ROM, October 29–Nov 2, 2005.

Crawford, G., A. Fernandez, A. Shawwa, and G. Daigger. 2002. Competitive Bidding and Evaluation of Membrane Bioreactor Equipment—Three Large Plant Case Studies. In *Proceedings of the Water Environment Federation 75th Annual Conference & Exposition*, Chicago, IL, CD-ROM, September 28–Oct 2, 2002.

Crawford, G., D. Thompson, J. Lozier, G. Daigger, and E. Fleischer. 2000. Membrane Bioreactors—A Designer's Perspective. In *Proceedings of the Water Environment Federation 73rd Annual Conference & Exposition on Water Quality and Wastewater Treatment*, Anaheim, CA, CD-ROM, October 14-18, 2000.

Fleischer, E.J., T.A. Broderick, G.T. Daigger, A. D. Fonseca, R.D. Holbrook, and S.N. Murthy. 2005. Evaluation of Membrane Bioreactor Process Capabilities to Meet Stringent Effluent Nutrient Discharge Requirements. *Water Environment Research* 77:162–178.

Fleischer, E. J., T. A. Broderick, G. T. Daigger, J. C. Lozier, A. M. Wollmann, and A. D. Fonseca. 2001. Evaluating the Next Generation of Water Reclamation Processes. In *Proceedings of the Water Environment Federation 74<sup>th</sup> Annual Conference & Exposition*, Atlanta, GA, CD-ROM, October 13–17, 2001.

Hermanowicz, S.W., D. Jenkins, R.P. Merlo, and R.S. Trussell. 2006. *Effects of Biomass Properties on Submerged Membrane Bioreactor (SMBR) Performance and Solids Processing*. Document no. 01-CTS-19UR. Water Environment Federation.

Metcalf & Eddy. 2003. *Wastewater Engineering, Treatment and Reuse*. 4th ed. McGraw-Hill, New York.

Wallis-Lage, C., B. Hemken, et al. 2006. *MBR Plants: Larger and More Complicated*. Presented at the Water Reuse Association's 21<sup>st</sup> Annual Water Reuse Symposium, Hollywood, CA, September 2006.

**TITAN MBR™**

**Marin Co., CA  
Woodacre / San Geronimo**

**December 13, 2016**





---

## **AN INTRODUCTION TO SMITH & LOVELESS, INC.**

Located in Lenexa, Kansas, Smith & Loveless is a leading U. S. manufacturer of water and wastewater treatment and pumping equipment. With its equipment utilized by municipalities and industries in the U.S. and around the world, the Smith & Loveless product line includes:

### **Wastewater Pumping Equipment up to 100,000 GPM**

The Smith & Loveless Non-Clog Pump was the first wastewater pump to use a mechanical seal and a 100% factory-built pump station. Since its invention, the Smith & Loveless pump has proven its reliability in more than 21,000 separate pumping installations worldwide. Smith & Loveless also developed the station that mounts directly on top of a wet well, pumping up to 7,500 GPM.

### **PRE-ENGINEERED TREATMENT PLANTS**

Smith & Loveless developed the market for smaller treatment plants designed for schools, subdivisions, hotels, hospitals, offshore drilling rigs, resorts, various industrial applications and municipalities. These plants have major advantages, which include proven design, lower cost installation and reduced construction time. Our treatment plants range in flow capacity from 1,000 GPD to 5 MGD in single units, with seven (7) separate product lines, including the **TITAN MBR™**.

### **WASTEWATER TREATMENT EQUIPMENT**

Smith & Loveless offers a complete line of wastewater treatment equipment for the larger component-type municipal and industrial systems. It is highlighted by the **PISTA®** Grit Removal System. Other well-known Smith & Loveless component products are the LOOP Brush Aerator, the Kraus-Fall peripheral-feed clarifier, the **PACE®** oil/water separator, the **DI-SEP®** SX Filter and the Marine **FAST®**.

### **Water Treatment Equipment**

Smith & Loveless also has a complete line of water treatment equipment. Included are the **FIBROTEX®**, the **IMF PROTECTOR™** Ultrafiltration System, the **IRONMAN™** System, the **SCIENCO®** Brinemaker, the **DI-SEP®** Nitrate Removal Filter, the **SCIENCO®** Sodium Hypochlorite Generator, the **CLAR-I-VATOR®** and more. This line encompasses both component equipment and package treatment plants from 10 GPD (0.6 lps).

### **COMPANY PROFILE**

Smith & Loveless was founded in 1946 by B. Alden Smith and Compere Loveless as a Sales Engineering Firm representing several manufacturers in the wastewater industry. Early in their association, Smith & Loveless recognized the need for complete factory-built wastewater pump stations and began manufacturing this equipment. Their first three stations were built for the municipal wastewater system of Salina, Kansas. These units were fabricated in a converted barn less than three miles from the present plant location.

As demand for this equipment grew, Smith & Loveless built their first manufacturing plant – a modest structure a few miles from the present plant site. Sales increased rapidly and within a short time, Smith & Loveless had sales representatives throughout the United States and Canada. Because of this rapid growth, it was necessary to expand the plant five times in four years.

The present site in Lenexa, Kansas (a Kansas City suburb) was selected in 1957. By 1958, the new manufacturing facility was ready for production. This present plant has been expanded several times, more than tripling the original manufacturing and office space (over 100,000 square feet of manufacturing space).

Late in 1959, Smith & Loveless was acquired by Trans Union Corporation, which was based in Lincolnshire, Illinois. This acquisition complemented markets served by other divisions of that firm, as well as providing additional capital for expansion and research and development, ensuring Smith & Loveless' leadership in the wastewater industry.

In February 1981, Trans Union merged with the Marmon Group, a largely privately held corporation.



In October 1981, the management of the Smith & Loveless Division purchased the assets of the Division from the Marmon Group, and Smith & Loveless, Inc., was reborn. Smith & Loveless renewed its commitment to maintain its role as a leader in the water and wastewater treatment and pumping industry through the design and production of quality equipment, and by providing superior service.

To continue to strengthen its leadership position, Smith & Loveless, on October 1, 1984, purchased two firms: **SCIENCO®**, Inc., of St. Louis, Missouri and **DI-SEP®** Systems International, Inc., of Santa Fe Springs, California. On August 1, 1985, Smith & Loveless added another subsidiary by acquiring St. Louis Marine Systems, Inc., renamed **FAST®** Systems, Inc. – Later, **SCIENCO®**, Inc., and **FAST®** Systems, Inc. were merged into **SCIENCO/FAST®** Systems, Inc. In 1987, Smith & Loveless made another step to provide additional capabilities in water treatment by acquiring K-W Industries. K-W was previously located in Omaha, Nebraska. In 1993, the above mentioned companies and their products were all absorbed into Smith & Loveless and its product line.

In a move to both strengthen Smith & Loveless, Inc.'s water product line and expand into the European marketplace, Smith & Loveless Limited, an affiliated company of Smith & Loveless, Inc., acquired the majority interest in Kalsep Limited of Camberley, England on March 29, 1995. Licenses granted allow Smith & Loveless products to be sold by Kalsep Limited and Kalsep Limited's water products to be sold in Smith & Loveless' markets.

In June 1996, in a move to specially develop, manufacture and market wastewater treatment systems for the on-site residential marketplace, an affiliated company, Bio-Microbics, Inc., was formed.

Further international expansion occurred on March 20, 1998, when Smith & Loveless New Zealand Ltd. Was granted licenses to market and sell Smith & Loveless, Inc. technology and equipment in New Zealand and Australia. And in a strategic move in August of 1999, Smith & Loveless Limited – UK began to more actively market and sell Smith & Loveless, Inc. technology in the UK.

On the domestic front, in June of 2000, Smith & Loveless Georgia Inc. was formed. This allows the Company to provide superior pump station sales and service for its Georgia customers.

Smith & Loveless actively pursues the patents of its inventions. The Company currently owns more than 50 active U.S. patents, holds foreign patents in 15 different countries, has several patent applications pending and has more than 25 domestic and foreign trademarks.

Smith & Loveless has actively engaged in R&D. Smith & Loveless' approach to research and development is both the search for new applications of existing product lines, as well as development of completely new concepts. Through these efforts, Smith & Loveless has been able to enter previously untapped markets. The Company's products are sold mainly through manufacturers' sales representative companies, with more than 150 such contract companies located worldwide.

Smith & Loveless employs approximately 250 people direct. Approximately 65 employees are represented by the United Steel, Paper and Forestry, Rubber, Manufacturing, Energy, Allied Industrial and Service Workers International Union Local No. 13-18. The total Lenexa, Kansas facility today encompasses 115,000 square feet of manufacturing and office space.

Smith & Loveless will continue to expand and offer new and better solutions for a world of water.



## 1.0 GENERAL DESCRIPTION

One (1) Smith & Loveless **TITAN MBR™** Treatment Plant, as described herein. The plant shall include separate zones: flow equalization, sludge holding, and aeration with **TITAN MBR™**.

Advantages of the Smith & Loveless **TITAN MBR™** include:

- Simple controls provide centralized information.
- System is factory-built, eliminating concrete pour on-site.
- V-Crimp wall design provides improved coatings application and longer tank life
- Factory-built reduces time required on-site by installing contractor.
- Flat-plate membrane is *Cleaned-In-Place* during normal operation.
- Flat-plane membrane eliminates the need for backwash and associated backwash tank.
- S&L membrane is gravity fed, eliminating the need for a permeate pump and associated O&M costs.
- S&L membranes located directly in aeration basin, eliminating the need for MLSS recirculation pump and associated O&M costs.
- Membrane modules arrive installed in the tank for a shorter install-to-start up lead time.
- Title 22 approved membrane modules.

### 1.01 TITAN MBR™ Performance Requirements

Flow:

<b>Option 1:</b>	75,000 gpd (ave)
<b>Option 2:</b>	50,000 gpd (ave)

Parameter:	Influent:	Effluent:
BOD:	250 mg/L	≤ 5 mg/L
TSS:	250 mg/L	≤ 5 mg/L
TKN:	45 mg/L	≤ 10 mg/L (expressed as TN)
Turbidity:		< 2 NTU

## 2.0 Basic Process Flow

The wastewater stream will pass through 3mm fine screen(s) prior to entering the plant.

The flow equalization zone will be equipped with an air ejector to transfer the wastewater into the membrane treatment system inside the aeration zone. Gravity will also be used to pass flow through the membranes, before exiting the MBR.

A recycle pump shall be used to send nitrified flow from the MBR/Aeration zone to the anoxic zone for denitrification.

Aeration zones will include fine bubble diffusers while coarse bubble diffusers are provided under the membrane module to for air scour of the membranes.

The sludge holding zone shall be used for further digestion of wasted sludge and increased operator flexibility.

The entire system will have the air supply distribution pipes inside the tank.

## 2.01 Basic Process Flow Diagram

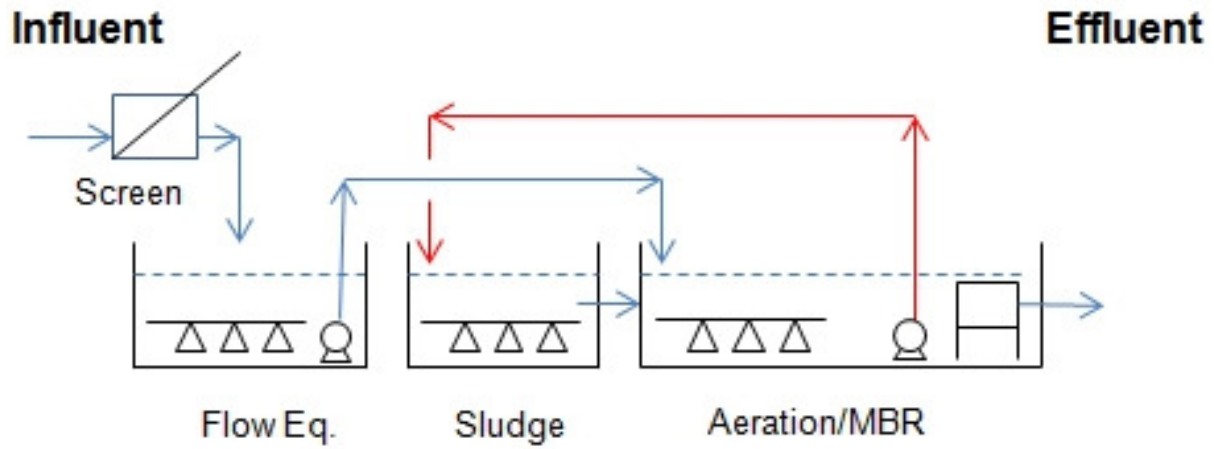

Isometric view outlines typical system look and components:

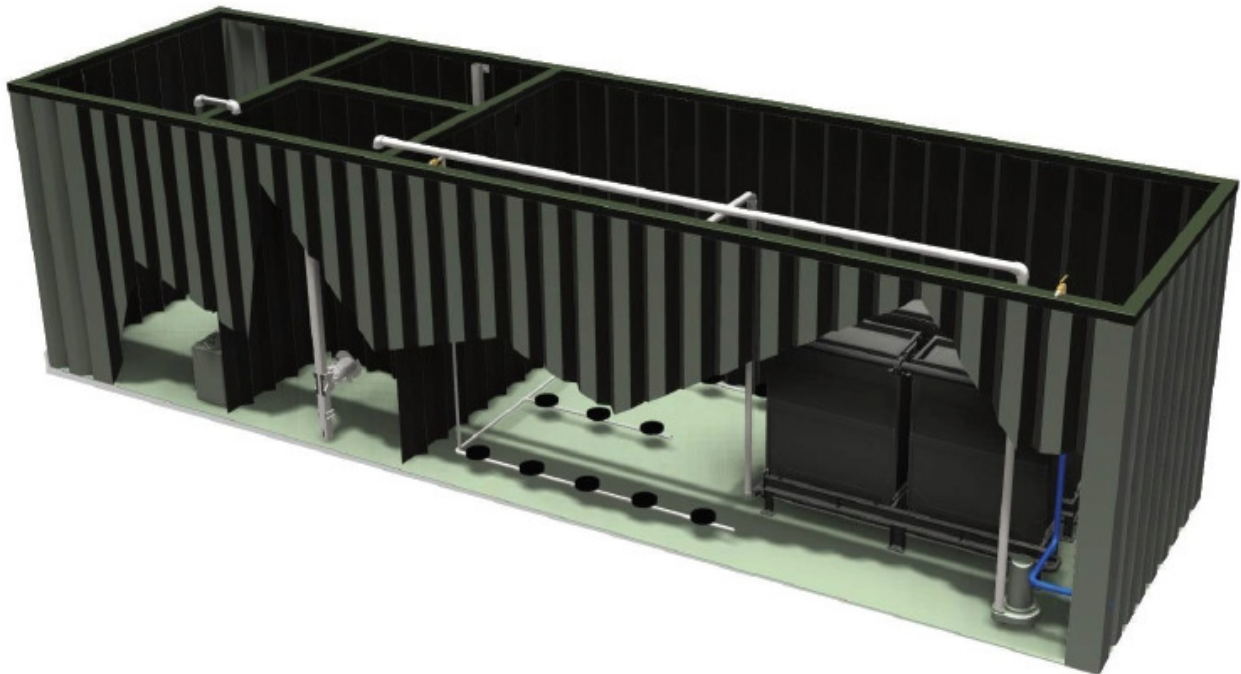

## 2.03 Typical plant layout (sludge holding not shown for clarity):

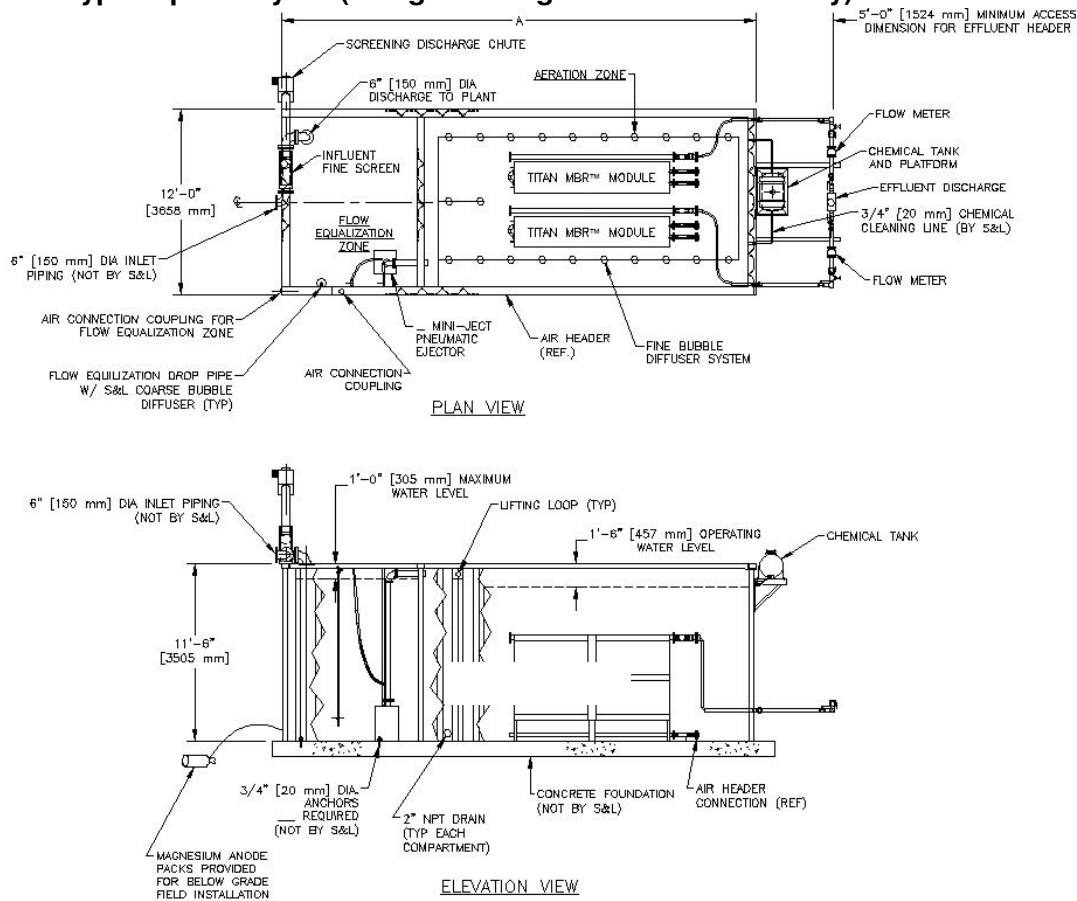

## 2.05 Scope of Supply

- 304 stainless steel, 3mm fine screen
- Factory built, epoxy coated tankage
- Membrane Bio Reactor modules (Title 22 Approved)
- Fine bubble diffusers
- Coarse bubble diffusers for flow equalization and sludge holding
- Air headers
- Air piping to Membrane Bio Reactor modules within tank
- Flow equalization **MINI-JECT®** ejector and associated discharge piping
- Wasting sludge airlift
- Valves for diffuser drop pipes
- Flow equalization blower
- Main plant blowers
- NEMA 4 Control Panel, including steel support stand and mounting hardware
- PLC controls with HMI, VFDs, and remote monitoring
- DO, pH, temperature, and other necessary probes
- Flow meter
- Chemical clean in place constant head tank and system





### **3.0 DELIVERY, TERMS, BUDGET PRICING**

#### **3.01 Delivery**

Submittal drawings and other technical engineering details are expected to be complete in 4-6 weeks after receipt of a purchase order. After approved drawings, manufacturing would take 20-22 weeks. Depending on factory work load, lead times may be improved.

#### **3.02 Payment Terms**

To be determined.

#### **3.03 Budget Price (fob, factory) – Offer Valid for 90 days**

**Option 1: 75,000 gal/day TITAN MBR™ system** ..... \$  
 Freight ..... Included  
 Start up and Training ..... Included

**Option 2: 50,000 gal/day TITAN MBR™ system** ..... \$  
 Freight ..... Included  
 Start up and Training ..... Included

#### **3.04 Items Not Included**

- Interconnecting piping and wiring (outside of tanks)
- Any civil work
- Any lighting of the site
- Excavation
- Any landscaping/roads around the plant
- Any buildings (if required)



Multi-tank layouts:





WASTEWATER DISINFECTION FILTERED IN-PIPE TREATMENT



## Proven TrojanUV Closed-Vessel Chambers for Reuse Disinfection. Validated, chemical-free disinfection from the industry leader

Around the globe, wastewater treatment plants of all sizes are responding to the water quality and quantity demands of the communities they serve. As more municipalities adopt wastewater reuse policies and practices, wastewater treatment plants are required to treat effluent to higher levels—essentially eliminating all pathogens prior to reuse or discharge.

Depending on site and design conditions, wastewater treatment plants producing filtered effluent sometimes prefer a disinfection solution using closed-vessel or pressurized UV chambers. The TrojanUVFit™ offers an effective and energy-efficient closed-vessel UV solution. This compact chamber is available in multiple configurations to treat a wide range of flow rates. The streamlined

hydraulic profile of closed-vessel systems disinfect filtered effluent without breaking head in the treatment process. These benefits, along with UV's ability to provide environmentally friendly, chemical-free treatment for chlorine resistant microorganisms (such as *Cryptosporidium* and *Giardia*) make the TrojanUVFit closed-vessel solution an attractive option for wastewater disinfection.

# Key Benefits

## TrojanUVFit

**Fully validated performance.** System sizing is based on actual dose delivery verified through bioassay validation. Real-world, field performance data eliminates sizing assumptions and risks associated with theoretical dose calculations.

**Compact design.** The small chamber footprint simplifies indoor retrofit installations and reduces construction costs.

**Reliable, proven components.** UV lamps, quartz sleeves, electronic lamp drivers, sensors and sleeve wiping system have been tested, proven reliable and are operating in hundreds of installations.

**Design flexibility.** Chambers can be installed in parallel or in series, making it simple to incorporate redundancy or future expansion needs.

**Wide range of flow rates.** Peak flow rates per chamber are suitable for either individual post-filter or manifold installation. Flows up to 7 MGD per chamber – the largest validated low-pressure lamp in-pipe wastewater system in the industry.

**Validated lamp performance.** Lamp output and aging characteristics validated through industry protocols and proven through years of operating experience.

**Automatic wiping.** Automatic sleeve wiping saves operator's time and money. Ensures the maximum UV output is available for disinfection and minimizes energy consumption.

**Global support. Local service.** Our comprehensive network of certified service providers offers fast response for service and spare parts.

**Guaranteed performance and comprehensive warranty.** Our systems include a Lifetime Disinfection Performance Guarantee.

# TROJAN UVFIT™

Designed for efficient, reliable performance

## System Control Center (SCC)

The microprocessor or Programmable Logic Controller (PLC) based controller continuously monitors and controls UV system functions. Supervisory Control and Data Acquisition (SCADA) communication for remote monitoring, control and dose pacing is available. Programmable digital and analog input/output (I/O) capabilities can generate unique alarms for individual applications and send signals to operate valves and pumps.

## Sleeve Wiping System

Automatic sleeve wiping system operates online without interrupting disinfection. The wiping sequence occurs automatically at preset intervals without operator involvement.

## Amalgam Lamps

High-output amalgam lamps are energy-efficient and save operating costs due to reduced electrical consumption. Lamps are located within protective quartz sleeves with easy access from the service entrance.



*This chamber contains lamps in both ends of the chamber. Multiple inlet and outlet flange orientations are available.*

## UV Intensity Sensor

Highly accurate, photodiode sensor monitors UV output within the chamber. The sensor ensures UV light is fully penetrating the water for complete disinfection.

## Power Distribution Center (PDC)

The PDC panel distributes power to the chamber, UV intensity sensor and sleeve wiping system. The panel also houses high-efficiency, variable-output lamp driver (60 – 100% power) with proven performance in hundreds of installations around the world.

## End Cap

The end cap protects and isolates connections for components such as lamps, sleeves and wiping system. Power is automatically disconnected if end cap is removed thereby ensuring a safe working environment for operators.

## UV Chamber

Electropolished 316L stainless steel chamber available in multiple configurations for a wide range of flow rates. Optional flange orientations allow chambers to fit into existing piping galleries or tight spaces.



## Regulatory-Endorsed Bioassay Validation

Field testing ensures accurate dose delivery

### Benefits:

- Validated in accordance with industry protocols established by National Water Research Institute (NWRI)
- Performance data is generated from actual field testing over a wide range of flow rates and water quality (UV transmission)
- Bioassay testing offers peace of mind and improved public and environmental safety due to verified dose delivery – not theoretical calculations

## Compact Chamber for Installation Flexibility

Efficient, cost-saving design enables retrofit or new construction

### Benefits:

- Compact footprint simplifies installation and minimizes related capital costs – ideal for retrofit and new construction applications
- Lamps and sleeves are fully serviceable from the chamber end – allowing the system to be installed against walls, other equipment or piping
- Low head loss design simplifies integration into existing process, and avoids additional pumping and associated capital and operational costs
- Multiple flange orientations available – increasing design flexibility



*Chambers can be installed in parallel or in series for increased design and installation flexibility.*

## Amalgam Lamps Require Less Energy

Maintain maximum output and reduce O&M costs

### Benefits:

- Each lamp draws 250 Watts
- Our amalgam lamps maintain 98% output during entire lamp life – 20% less decline than competitive UV lamps
- Validated performance provides assurance of reliable dose delivery and prolonged lamp life
- Deliver consistent and stable UV output over a wide range of water temperatures



# Built for Reliable Performance and Easy Maintenance

Designed for trouble-free operation and minimal service

## Benefits:

- Routine procedures, including lamp change-outs are simple and require minimal time – reducing maintenance costs
- Access to internal components (lamps, sleeves, cleaning system) through service entrance at one end
- Service entrance and connections protected by end cap
- Intensity sensor continuously monitors UV output to ensure dose delivery



*The TrojanUVFit lamps are easily replaced in minutes without the need for tools.*

# Robust Sleeve Wiping System

Automatic wiping system maintains consistent dose delivery

## Benefits:

- Wiping system minimizes fouling of quartz sleeves
- Ensures consistent UV dose delivery and optimum performance
- Automatic wiping occurs while the lamps are disinfecting, reducing downtime
- Optional off-line chemical cleaning to reduce maintenance associated with manual cleaning

# User-Friendly Operator Interface

Touchscreen display allows easy operation and monitoring

## Benefits:

- Microprocessor or PLC-based system controls all functions and dose pacing to minimize energy use while maintaining required UV dose
- Controller features intuitive, graphical display for at-a-glance system status
- Controller communicates with plant SCADA systems for centralized monitoring of performance, lamp status, power levels, hours of operation and alarm status

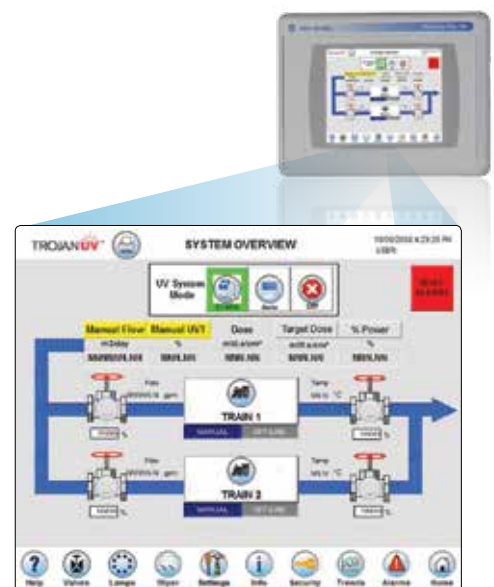

*The PLC-based controller combines sophisticated system operation and reporting with an operator-friendly, touchscreen display.*

System Specifications												
Model	04AL20		08AL20		18AL40		32AL50		72AL75		D72AL75	
Number of Lamps	4		8		18		32		72		144	
Lamp Type	High-efficiency, High-output, Low-pressure Amalgam											
Sleeve Wiping	Automatic wiping system											
Lamp Driver	Electronic, constant output (100% power) or electronic, variable output (60 to 100% power)											
Chamber												
Materials of Construction	316L Stainless Steel											
Standard Flange Size (ANSI/DIN), inches (mm)	6 (150)			10 (250)		12 (300)		20 (500)		20 (500)		
Outlet Flange Orientation	Multiple orientations available 3, 6, 9 or 12 o'clock position											
Approx. Chamber Length, inches (mm)	80 (2032)		80 (2032)		82 (2083)		90 (2286)		90 (2286)		152 (3860)	
Max. Operating Pressure, PSI (bar)	150 (10)		150 (10)		150 (10)		100 (6.8)		65 (4.5)		65 (4.5)	
Dry Chamber Weight, lbs (kg)	107 (49)		115 (52)		400 (181)		1600 (726)		2100 (953)		3700 (1678)	
Wet Chamber Weight, lbs (kg)	230 (105)			877 (398)		2200 (998)		3700 (1678)		7200 (3265)		
Power Distribution Center (PDC)												
Electrical Supply	Standard: Single phase, 2 wire + gnd, 50/60 Hz L-L	120V	N/A		N/A		N/A		N/A		N/A	
		208V	✓		✓		✓		✓		N/A	
		240V	✓		✓		✓		✓		N/A	
Electrical Supply	3 Phase, 4 wire + gnd, 50/60 Hz	400/230V	N/A		N/A		✓		✓		✓	
		Dimensions (H x W x D) inches (mm)	Type 12	30 x 16 x 10 (760 x 410 x 250)			36 x 30 x 10 (920 x 760 x 250)		60 x 36 x 10 (1520 x 920 x 250)		86 x 48 x 24 (2184 x 1219 x 610)	
Material	Type 3R	30 x 24 x 10 (760 x 610 x 250)			60 x 36 x 12 (1520 x 920 x 305)		Painted Mild Steel		Painted Mild Steel			
	Type 4X	304 Stainless (1.4301 in Europe)			Painted Mild Steel		304 Stainless (1.4301 in Europe)					
	Panel Rating	NEMA 12, 3R or 4X					NEMA 12 or 4X					
Network Interface	Modbus RTU RS485, Modbus TCP/IP, AB Ethernet I/P, ProfiNet							N/A				
System Control Center (SCC)												
Panel is Required/Optional	N/A (requires only PDC)					Optional		Required				
Electrical	N/A (see PDC)					Two (2) Supplies of 120 V single phase, 2 wire plus ground, 60 Hz, 1.2 kVA (one (1) for the PLC, one (1) for lights & heater)						
Material	Type 12	Painted Mild Steel										
	Type 4X	Stainless(1.4301 in Europe)										
Panel Rating	N/A (see PDC)					NEMA 12 or 4X						
Typical Outputs Provided	Chamber status, common alarms and SCADA communication											
Network Interface	Modbus RTU RS485, Modbus TCP/IP, AB Ethernet I/P, ProfiNet											

TrojanUV is part of the Trojan Technologies group of businesses.

#### Head Office (Canada)

3020 Gore Road London, Ontario, Canada N5V 4T7  
Telephone: (519) 457-3400 Fax: (519) 457-3030

[www.trojanuv.com](http://www.trojanuv.com)

#### Trojan Technologies Deutschland GmbH

Aschaffener Str. 72, 63825 Schöllkrippen, Germany  
Telephone: +49 (0) 6024 6347580 Fax: +49 (0) 6024 6347588

For a list of our global offices, please visit [trojanuv.com/contactus](http://trojanuv.com/contactus).

The products described in this publication may be protected by one or more patents in The United States of America, Canada and/or other countries. For a list of patents owned by Trojan Technologies, go to [www.trojan technologies.com](http://www.trojan technologies.com).

Copyright 2015, Trojan Technologies London, Ontario, Canada.

No part of this publication may be reproduced, stored in a retrieval system, or transmitted in any form or by any means without the written permission of Trojan Technologies. (0915)



ISO 9001:2008 CERTIFIED

# ENVIRODYNE SYSTEMS INC.

Custom Water & Wastewater Treatment Equipment - Since 1971



[HOME](#)

[WATER & WASTEWATER](#)

[DIGESTION & DEWATERING](#)

[INDUSTRIAL & MINING](#)

[ENVIRODYNE DOES...](#)

Search



## Sludge Bagging Systems

[Home](#) > [Sludge Bagging Systems](#)



The All-American™ Sludge Bagger is an economical alternative to drying beds, liquid hauling and other technologies for small sludge flows dewatering.

The All-American™ Sludge Bagger has been featured in *Operations Forum*, a Water Environment Federation



ISO 9001:2008 CERTIFIED

# ENVIRODYNE SYSTEMS INC.

Custom Water & Wastewater Treatment Equipment - Since 1971



# Water Balance Calculations and Reference Data

- Methodology & Summary Table
- Water Balance Worksheets
- Rainfall and Evaporation Data

## **Recycled Water Storage Ponds Water Balance Methodology**

1. Develop preliminary layout and configuration of proposed storage ponds based on available land area, site features and minimum 2:1 graded cut and fill slopes; calculate cut and fill volumes.
2. Determine volume-depth relationships (rating curve), bottom area, surface “catchment” area; determine maximum storage volume of each pond up to a depth of 2 feet below top of pond (freeboard).
3. Obtain best estimates of average monthly rainfall data for Woodacre Fire Station (41.6 inches); develop estimates of 10-yr and 100-yr seasonal rainfall amounts from statistical analysis of long-term rainfall records for San Rafael and Kentfield; apply results (“multiplier”) to average monthly values to obtain estimates of 10-yr and 100-yr rainfall for Woodacre.
4. Develop estimates of monthly water surface evaporation from MMWD data for Lake Lagunitas pan evaporation data and use of 0.8 coefficient per NOAA National Weather Service guidelines and maps.
5. Construct monthly water balance calculation worksheet covering annual cycle, November through October; assumes pond empty on November 1<sup>st</sup> of each year;
  - a. **Wet weather season:** calculate net water volume additions from direct rainfall (100-yr values) plus assumed wastewater additions, minus loss of water to evaporation for each month; accumulate total volume in pond storage from month to month until maximum storage volume is reached; trial-and-error calculations adjusting the assumed daily/monthly wastewater inflow to determine maximum wastewater flow capacity (gpd).
  - b. **Dry weather season:** continue water balance calculations through dry (irrigation) season (April-October), accounting for additional outflow of recycled water from pond for irrigation uses; trial-and-error calculations to determine volume of recycled water discharged to drain pond by end of October.
6. Run calculations for average, 10-yr and 100-yr rainfall conditions for each pond; tally results to estimate recycled water production volumes for **Alternative Projects 4, 5a and 5b**.
7. Modify and run water balance calculations for **Alternative 6**, including: (a) supplemental treated water input to storage ponds year-round (from expanded service area flows) during average and 10-yr rainfall conditions year-round; and (b) supplemental treated water during dry season only for 100-yr rainfall conditions.

**Estimated Recycled Water Production**

Alternative	Service Area	Parcels/ESDs	Estimated Average WW Flow (gpd)	Ponds/Storage	Average Rainfall Year		10-Yr Rainfall		100-Yr Rainfall		
					MGAL	AC-FT	MGAL	AC-FT	MGAL	AC-FT	
4	Woodacre	210	26,000	<b>Front</b>	<b>9,223,400</b>	<b>28.3</b>	<b>10,090,100</b>	<b>31.0</b>	<b>10,785,600</b>	<b>33.1</b>	
5A	Woodacre & San Geronimo	270	33,200	Front	9,223,400	28.3	10,090,100	31.0	10,785,600	33.1	
				Back Upper	n/a	n/a	n/a	n/a	n/a	n/a	n/a
				Back Lower	3,035,250	9.3	3,514,500	10.8	3,897,900	12.0	
				<b>Total</b>	<b>12,258,650</b>	<b>37.6</b>	<b>13,604,600</b>	<b>41.8</b>	<b>14,683,500</b>	<b>45.1</b>	
5B	Woodacre & San Geronimo	360	44,000	Front	9,223,400	28.3	10,090,100	31.0	10,785,600	33.1	
				Back Upper	4,025,700	12.4	4,600,800	14.1	5,054,490	15.5	
				Back Lower	3,035,250	9.3	3,514,500	10.8	3,897,900	12.0	
				<b>Total</b>	<b>16,284,350</b>	<b>50.0</b>	<b>18,205,400</b>	<b>55.9</b>	<b>19,737,990</b>	<b>60.6</b>	
6	Woodacre, San Geronimo, Lagunitas School French Ranch (Others)	420+	53,300	Front	10,550,200	32.4	11,309,900	34.7	11,427,600	35.1	
				Back Upper	4,291,950	13.2	4,867,050	14.9	5,293,050	16.2	
				Back Lower	3,418,650	10.5	3,897,900	12.0	4,089,600	12.6	
				<b>Total</b>	<b>18,260,800</b>	<b>56.0</b>	<b>20,074,850</b>	<b>61.6</b>	<b>20,810,250</b>	<b>63.9</b>	

# **Pond Water Balance Worksheets**

Average, 10-yr and 100-yr Rainfall



**WOODACRE-SAN GERONIMO WASTEWATER RECYCLING STUDY**  
**FRONT NINE POND WATER BALANCE FOR 100-YR. RAINFALL - MAX. WW FLOW, POND CAPACITY**

Front Nine Pond #1 - 100-Year

**WASTEWATER FLOW** 26,000 GPD, Winter 21,800 GPD, Summer  
**MAX POND SURFACE AREA** 73,780 SQUARE FEET  
**AVERAGE BANK SLOPE** 2.00 :1  
**MAXIMUM VOLUME** 6,446,967 GALLONS  
 861,779 CUBIC FEET  
**MAXIMUM WATER DEPTH** 18.0 FEET  
**MAX DEPTH WITH 2-FT FREEBOARD** 2.0 FEET

Month	Days in Month	Wastewater Inflow		Precipitation		Evaporation*		Recycled Water Produced		Volume Change	Total Balance Volume		End Water Depth
		WW (gal)	(ft <sup>3</sup> )	P (in)	(ft <sup>3</sup> )	Eto (in)	(ft <sup>3</sup> )	Irr. (gpd)	(ft <sup>3</sup> )	ΔV (ft <sup>3</sup> )	V (ft <sup>3</sup> )	(gal)	ft
NOV	30	780,000	104,286	9.28	57,033	0.98	5,121	0	0	156,199	156,199	1,168,522	4.7
DEC	31	806,000	107,762	14.49	89,084	0.94	4,956	0	0	191,890	348,089	2,604,051	9.2
JAN	31	806,000	107,762	16.99	104,441	1.83	9,581	0	0	202,622	550,711	4,119,867	13.0
FEB	28	728,000	97,334	13.62	83,742	2.87	15,032	0	0	166,043	716,754	5,362,036	15.8
MAR	31	806,000	107,762	9.57	58,814	4.13	21,640	0	0	144,936	861,690	6,446,306	18.0
APR	30	654,000	87,440	4.34	26,708	4.94	25,935	50,400	202,154	-113,941	747,750	5,593,914	16.3
MAY	31	675,800	90,354	1.86	11,407	5.32	27,917	50,400	208,893	-135,049	612,701	4,583,615	14.1
JUN	30	654,000	87,440	0.51	3,116	4.66	24,448	50,400	202,154	-136,047	476,654	3,565,851	11.7
JUL	31	675,800	90,354	0.08	501	3.53	18,501	50,400	208,893	-136,539	340,115	2,544,404	9.0
AUG	30	654,000	87,440	0.15	946	2.08	10,902	50,400	202,154	-124,671	215,444	1,611,739	6.2
SEP	30	654,000	87,440	0.71	4,340	1.10	5,782	50,400	202,154	-116,156	99,288	742,775	3.1
OCT	31	675,800	90,354	3.70	22,758	0.72	3,799	50,400	208,893	-99,580	-292	-2,183	-0.1
<b>Totals:</b>		<b>8,569,400</b>	<b>1,145,729</b>	<b>75.3</b>	<b>462,889</b>	<b>33.1</b>	<b>173,614</b>	<b>10,785,600</b>	<b>1,435,296</b>	<b>-292</b>	<b>5,125,103</b>	<b>38,340,897</b>	

Notes:

\*Evaporation rates at 0.8\*Pan A mean rate for Lake Lagunitas, 1987-1994, MMWD

Evap calculated based on water surface area at 50% pond capacity (vol)

Pond bottom area, SQ FT:

32,632

<b>Annual Recycled Water Volume:</b>	<b>10.79</b>	Mgal
	<b>33.10</b>	ac-ft

**WOODACRE- SAN GERONIMO WASTEWATER RECYCLING STUDY**  
**BACK NINE LOWER POND WATER BALANCE FOR 100-YR. RAINFALL - MAX WW FLOW, POND CAPACITY**

**Back Nine Lower Pond - 100-Year**

WASTEWATER INFLOW 7,800 GPD, Winter 6,500 GPD, Summer  
 POND WATERSHED AREA 40,990 SQUARE FEET  
 AVERAGE BANK SLOPE 2.00 :1

**MAXIMUM VOLUME** 2,620,000 GALLONS  
 350,221 CUBIC FEET

**MAXIMUM WATER DEPTH** 15.0 FEET  
**MAX DEPTH WITH 2-FT FREEBOARD** 2.0 FEET

Month	Days in Month	Wastewater Inflow		Precipitation		Evaporation		Recycled Water Produced		Volume Change ΔV (ft <sup>3</sup> )	Total Balance Volume		End Water Depth (ft)
		WW (gal)	(ft <sup>3</sup> )	P (in)	(ft <sup>3</sup> )	Eto (in)	(ft <sup>3</sup> )	Irr. (gpd)	(ft <sup>3</sup> )		V (ft <sup>3</sup> )	(gal)	
NOV	30	234,000	31,286	9.28	31,686	0.98	2,337	0	0	60,635	60,635	453,611	4.3
DEC	31	241,800	32,329	14.49	49,492	0.94	2,261	0	0	79,559	140,194	1,048,794	8.1
JAN	31	241,800	32,329	16.99	58,024	1.83	4,372	0	0	85,981	226,175	1,692,016	11.3
FEB	28	218,400	29,200	13.62	46,525	2.87	6,860	0	0	68,865	295,040	2,207,193	13.5
MAR	31	241,800	32,329	9.57	32,675	4.13	9,875	0	0	55,129	350,169	2,619,611	15.1
APR	30	195,000	26,072	4.34	14,838	4.94	11,835	18,300	73,401	-44,327	305,842	2,288,004	13.8
MAY	31	201,500	26,941	1.86	6,337	5.32	12,740	18,300	75,848	-55,310	250,532	1,874,230	12.1
JUN	30	195,000	26,072	0.51	1,731	4.66	11,157	18,300	73,401	-56,755	193,777	1,449,643	10.2
JUL	31	201,500	26,941	0.08	278	3.53	8,443	18,300	75,848	-57,072	136,704	1,022,686	8.0
AUG	30	195,000	26,072	0.15	526	2.08	4,975	18,300	73,401	-51,780	84,925	635,323	5.6
SEP	30	195,000	26,072	0.71	2,411	1.10	2,638	18,300	73,401	-47,557	37,368	279,550	2.9
OCT	31	201,500	26,941	3.70	12,644	0.72	1,734	18,300	75,848	-37,998	-630	-4,711	-0.1
<b>Totals:</b>		<b>2,562,300</b>	<b>342,580</b>	<b>75.3</b>	<b>257,168</b>	<b>33.1</b>	<b>79,228</b>	<b>3,897,900</b>	<b>521,149</b>	<b>-630</b>	<b>2,080,731</b>	<b>15,565,949</b>	

Notes:

\*Evaporation rates at 0.8\*Pan A mean rate for Lake Lagunitas, 1987-1994, MMWD

Evap calculated based on water surface area at 50% pond capacity (vol)

Pond bottom area, SQ FT:

11,200

<b>Annual Recycled Water Volume:</b>	<b>3.90</b>	Mgal
	<b>11.96</b>	ac-ft

**WOODACRE - SAN GERONIMO WASTEWATER RECYCLING STUDY**  
**BACK NINE UPPER POND WATER BALANCE FOR 100-YR. RAINFALL - MAX WW FLOWS AT POND CAPACITY**

**Back Nine Upper Pond - 100-yr**

WASTEWATER INFLOW 10,200 GPD, Winter 8,500 gpd, Summer  
 POND WATERSHED AREA 48,960 SQUARE FEET  
 AVERAGE BANK SLOPE 2.00 :1  
**MAXIMUM VOLUME** 3,300,000 GALLONS  
 441,117 CUBIC FEET  
**MAXIMUM WATER DEPTH** 15.0 FEET  
**MAX DEPTH WITH 2-FT FREEBOARD** 2.0 FEET

Month	Days in Month	Wastewater Inflow		Precipitation		Evaporation*		Recycled Water Produced		Volume Change ΔV (ft <sup>3</sup> )	Total Balance Volume		End Water Depth (ft)
		WW (gal)	(ft <sup>3</sup> )	P (in)	(ft <sup>3</sup> )	Eto (in)	(ft <sup>3</sup> )	Irr. (gpd)	(ft <sup>3</sup> )		V (ft <sup>3</sup> )	(gal)	
NOV	30	306,000	40,912	9.28	37,847	0.98	2,337	0	0	76,422	76,422	571,716	4.2
DEC	31	316,200	42,276	14.49	59,115	0.94	2,261	0	0	99,130	175,552	1,313,306	8.0
JAN	31	316,200	42,276	16.99	69,306	1.83	4,372	0	0	107,210	282,762	2,115,344	11.2
FEB	28	285,600	38,185	13.62	55,571	2.87	6,860	0	0	86,895	369,658	2,765,409	13.4
MAR	31	316,200	42,276	9.57	39,029	4.13	9,875	0	0	71,429	441,087	3,299,773	15.1
APR	30	255,000	34,094	4.34	17,724	4.94	11,835	23,730	95,181	-55,199	385,888	2,886,828	13.8
MAY	31	263,500	35,230	1.86	7,569	5.32	12,740	23,730	98,354	-68,294	317,594	2,375,919	12.1
JUN	30	255,000	34,094	0.51	2,068	4.66	11,157	23,730	95,181	-70,176	247,417	1,850,929	10.2
JUL	31	263,500	35,230	0.08	332	3.53	8,443	23,730	98,354	-71,234	176,183	1,318,025	8.0
AUG	30	255,000	34,094	0.15	628	2.08	4,975	23,730	95,181	-65,435	110,748	828,505	5.6
SEP	30	255,000	34,094	0.71	2,880	1.10	2,638	23,730	95,181	-60,846	49,902	373,317	2.9
OCT	31	263,500	35,230	3.70	15,102	0.72	1,734	23,730	98,354	-49,756	146	1,094	0.0
<b>Totals:</b>		<b>3,350,700</b>	<b>447,989</b>	<b>75.3</b>	<b>307,171</b>	<b>33.1</b>	<b>79,228</b>	<b>5,054,490</b>	<b>675,785</b>	<b>146</b>	<b>2,633,360</b>	<b>19,700,165</b>	

Notes:

\*Evaporation rates at 0.8\*Pan A mean rate for Lake Lagunitas, 1987-1994, MMWD

Evap calculated based on water surface area at 50% pond capacity (vol)

Pond bottom area, SQ FT: 14,316

<b>Annual Recycled Water Volume:</b>	<b>5.05</b>	Mgal
	<b>15.51</b>	ac-ft

**WOODACRE-SAN GERONIMO WASTEWATER RECYCLING STUDY**  
**FRONT NINE POND WATER BALANCE FOR AVE-YR. RAINFALL**

Front Nine Pond #1 - Average Year

WASTEWATER FLOW 26,000 GPD, Winter 21,800 GPD, Summer  
 MAX POND SURFACE AREA 73,780 SQUARE FEET  
 AVERAGE BANK SLOPE 2.00 :1  
 MAXIMUM VOLUME 6,446,967 GALLONS  
 861,779 CUBIC FEET  
 MAXIMUM WATER DEPTH 18.0 FEET  
 MAX DEPTH WITH 2-FT FREEBOARD 2.0 FEET

Month	Days in Month	Wastewater Inflow		Precipitation		Evaporation*		Recycled Water Produced		Volume Change ΔV (ft <sup>3</sup> )	Total Balance Volume		End Water Depth ft
		WW (gal)	(ft <sup>3</sup> )	P (in)	(ft <sup>3</sup> )	Eto (in)	(ft <sup>3</sup> )	Irr. (gpd)	(ft <sup>3</sup> )		V (ft <sup>3</sup> )	(gal)	
NOV	30	780,000	104,286	5.13	31,510	0.98	5,121	0	0	130,675	130,675	977,582	4.0
DEC	31	806,000	107,762	8.01	49,217	0.94	4,956	0	0	152,024	282,699	2,114,873	7.7
JAN	31	806,000	107,762	9.39	57,702	1.83	9,581	0	0	155,883	438,583	3,281,037	11.0
FEB	28	728,000	97,334	7.53	46,266	2.87	15,032	0	0	128,568	567,150	4,242,851	13.3
MAR	31	806,000	107,762	5.29	32,494	4.13	21,640	0	0	118,616	685,767	5,130,220	15.3
APR	30	654,000	87,440	2.40	14,756	4.94	25,935	43,100	172,874	-96,613	589,154	4,407,459	13.7
MAY	31	675,800	90,354	1.03	6,302	5.32	27,917	43,100	178,637	-109,897	479,257	3,585,319	11.7
JUN	30	654,000	87,440	0.28	1,722	4.66	24,448	43,100	172,874	-108,161	371,096	2,776,169	9.6
JUL	31	675,800	90,354	0.05	277	3.53	18,501	43,100	178,637	-106,507	264,589	1,979,393	7.3
AUG	30	654,000	87,440	0.09	523	2.08	10,902	43,100	172,874	-95,814	168,775	1,262,607	5.0
SEP	30	654,000	87,440	0.39	2,398	1.10	5,782	43,100	172,874	-88,818	79,957	598,159	2.6
OCT	31	675,800	90,354	2.05	12,573	0.72	3,799	43,100	178,637	-79,508	449	3,359	0.0
<b>Totals:</b>		<b>8,569,400</b>	<b>1,145,729</b>	<b>41.60</b>	<b>255,740</b>	<b>33.1</b>	<b>173,614</b>	<b>9,223,400</b>	<b>1,227,406</b>	<b>449</b>	<b>4,058,151</b>	<b>30,359,027</b>	

Notes:

\*Evaporation rates at 0.8\*Pan A mean rate for Lake Lagunitas, 1987-1994, MMWD

Evap calculated based on water surface area at 50% pond capacity (vol)

Pond bottom area, SQ FT:

32,632

Annual Recycled Water Volume:	9.22	Mgal
	28.31	ac-ft

**WOODACRE - SAN GERONIMO WASTEWATER RECYCLING STUDY**  
**BACK NINE LOWER POND WATER BALANCE FOR AVE-YR. RAINFALL**

**Back Nine Lower Pond - Ave Year**

**WASTEWATER INFLOW** 7,800 GPD, Winter 6,500 GPD, Summer  
**POND WATERSHED AREA** 40,990 SQUARE FEET  
**AVERAGE BANK SLOPE** 2.00 :1  
**MAXIMUM VOLUME** 2,600,000 GALLONS  
 347,547 CUBIC FEET  
**MAXIMUM WATER DEPTH** 15.0 FEET  
**MAX DEPTH WITH 2-FT FREEBOARD** 2.0 FEET

Month	Days in Month	Wastewater Inflow		Precipitation		Evaporation		Recycled Water Produced		Volume Change ΔV (ft <sup>3</sup> )	Total Balance Volume		End Water Depth (ft)
		WW (gal)	(ft <sup>3</sup> )	P (in)	(ft <sup>3</sup> )	Eto (in)	(ft <sup>3</sup> )	Irr. (gpd)	(ft <sup>3</sup> )		V (ft <sup>3</sup> )	(gal)	
NOV	30	234,000	31,286	5.13	17,506	0.98	2,337	0	0	46,455	46,455	347,530	3.5
DEC	31	241,800	32,329	8.01	27,344	0.94	2,261	0	0	57,411	103,866	777,021	6.5
JAN	31	241,800	32,329	9.39	32,058	1.83	4,372	0	0	60,014	163,880	1,225,986	9.0
FEB	28	218,400	29,200	7.53	25,704	2.87	6,860	0	0	48,044	211,924	1,585,406	10.8
MAR	31	241,800	32,329	5.29	18,053	4.13	9,875	0	0	40,506	252,431	1,888,433	12.2
APR	30	195,000	26,072	2.40	8,198	4.94	11,835	14,250	57,157	-34,722	217,708	1,628,674	11.0
MAY	31	201,500	26,941	1.03	3,501	5.32	12,740	14,250	59,062	-41,360	176,348	1,319,260	9.5
JUN	30	195,000	26,072	0.28	956	4.66	11,157	14,250	57,157	-41,286	135,063	1,010,403	7.9
JUL	31	201,500	26,941	0.05	154	3.53	8,443	14,250	59,062	-40,411	94,652	708,091	6.1
AUG	30	195,000	26,072	0.09	290	2.08	4,975	14,250	57,157	-35,770	58,882	440,495	4.2
SEP	30	195,000	26,072	0.39	1,332	1.10	2,638	14,250	57,157	-32,391	26,490	198,174	2.1
OCT	31	201,500	26,941	2.05	6,985	0.72	1,734	14,250	59,062	-26,870	-380	-2,840	-0.1
<b>Totals:</b>		<b>2,562,300</b>	<b>342,580</b>	<b>41.60</b>	<b>142,082</b>	<b>33.1</b>	<b>79,228</b>	<b>3,035,250</b>	<b>405,813</b>	<b>-380</b>	<b>1,487,319</b>	<b>11,126,635</b>	

Notes:

\*Evaporation rates at 0.8\*Pan A mean rate for Lake Lagunitas, 1987-1994, MMWD

Evap calculated based on water surface area at 50% pond capacity (vol)

Pond bottom area, SQ FT: 11,200

<b>Annual Recycled Water Volume:</b>	<b>3.04</b>	Mgal
	<b>9.31</b>	ac-ft

**WOODACRE - SAN GERONIMO WASTEWATER RECYCLING STUDY**  
**BACK NINE UPPER POND WATER BALANCE FOR AVE-YR. RAINFALL**

**Back Nine Upper Pond - Ave Year**

**WASTEWATER INFLOW** 10,200 GPD, Winter 8,500 gpd, Summer  
**POND WATERSHED AREA** 48,960 SQUARE FEET  
**AVERAGE BANK SLOPE** 2.00 :1  
**MAXIMUM VOLUME** 3,300,000 GALLONS  
 441,117 CUBIC FEET  
**MAXIMUM WATER DEPTH** 15.0 FEET  
**MAX DEPTH WITH 2-FT FREEBOARD** 2.0 FEET

Month	Days in Month	Wastewater Inflow		Precipitation		Evaporation		Recycled Water Produced		Volume Change ΔV (ft <sup>3</sup> )	Total Balance Volume		End Water Depth (ft)
		WW (gal)	(ft <sup>3</sup> )	P (in)	(ft <sup>3</sup> )	Eto (in)	(ft <sup>3</sup> )	Irr. (gpd)	(ft <sup>3</sup> )		V (ft <sup>3</sup> )	(gal)	
NOV	30	306,000	40,912	5.13	20,910	0.98	2,337	0	0	59,485	59,485	445,010	3.4
DEC	31	316,200	42,276	8.01	32,660	0.94	2,261	0	0	72,675	132,160	988,690	6.4
JAN	31	316,200	42,276	9.39	38,291	1.83	4,372	0	0	76,195	208,355	1,558,701	9.0
FEB	28	285,600	38,185	7.53	30,702	2.87	6,860	0	0	62,027	270,382	2,022,724	10.8
MAR	31	316,200	42,276	5.29	21,563	4.13	9,875	0	0	53,964	324,345	2,426,425	12.3
APR	30	255,000	34,094	2.40	9,792	4.94	11,835	18,900	75,808	-43,758	280,588	2,099,075	11.1
MAY	31	263,500	35,230	1.03	4,182	5.32	12,740	18,900	78,335	-51,663	228,925	1,712,587	9.7
JUN	30	255,000	34,094	0.28	1,142	4.66	11,157	18,900	75,808	-51,729	177,196	1,325,604	8.0
JUL	31	263,500	35,230	0.05	184	3.53	8,443	18,900	78,335	-51,364	125,832	941,349	6.2
AUG	30	255,000	34,094	0.09	347	2.08	4,975	18,900	75,808	-46,343	79,489	594,658	4.3
SEP	30	255,000	34,094	0.39	1,591	1.10	2,638	18,900	75,808	-42,762	36,727	274,758	2.2
OCT	31	263,500	35,230	2.05	8,344	0.72	1,734	18,900	78,335	-36,495	232	1,738	0.0
<b>Totals:</b>		<b>3,350,700</b>	<b>447,989</b>	<b>41.60</b>	<b>169,708</b>	<b>33.1</b>	<b>79,228</b>	<b>4,025,700</b>	<b>538,236</b>	<b>232</b>	<b>1,923,716</b>	<b>14,391,320</b>	

<b>Annual Recycled Water Volume:</b>	<b>4.03</b>	<b>Mgal</b>
	<b>12.35</b>	<b>ac-ft</b>

Notes:  
 \*Evaporation rates at 0.8\*Pan A mean rate for Lake Lagunitas, 1987-1994, MMWD  
 Evap calculated based on water surface area at 50% pond capacity (vol)  
 Pond bottom area, SQ FT: 14,316

**WOODACRE-SAN GERONIMO WASTEWATER RECYCLING STUDY  
FRONT NINE POND WATER BALANCE FOR 10-YR. RAINFALL**

Front Nine Pond #1 - 10-Year

**WASTEWATER FLOW** 26,000 GPD, Winter 21,800 GPD, Summer  
**MAX POND SURFACE AREA** 73,780 SQUARE FEET  
**AVERAGE BANK SLOPE** 2.00 :1  
**MAXIMUM VOLUME** 6,446,967 GALLONS  
 861,779 CUBIC FEET  
**MAXIMUM WATER DEPTH** 18.0 FEET  
**MAX DEPTH WITH 2-FT FREEBOARD** 2.0 FEET

Month	Days in Month	Wastewater Inflow		Precipitation		Evaporation*		Recycled Water Produced		Volume Change ΔV (ft <sup>3</sup> )	Total Balance Volume		End Water Depth ft
		WW (gal)	(ft <sup>3</sup> )	P (in)	(ft <sup>3</sup> )	Eto (in)	(ft <sup>3</sup> )	Irr. (gpd)	(ft <sup>3</sup> )		V (ft <sup>3</sup> )	(gal)	
NOV	30	780,000	104,286	7.43	45,690	0.98	5,121	0	0	144,855	144,855	1,083,660	4.4
DEC	31	806,000	107,762	11.61	71,365	0.94	4,956	0	0	174,172	319,027	2,386,639	8.5
JAN	31	806,000	107,762	13.61	83,668	1.83	9,581	0	0	181,849	500,876	3,747,053	12.1
FEB	28	728,000	97,334	10.91	67,086	2.87	15,032	0	0	149,387	650,263	4,864,621	14.7
MAR	31	806,000	107,762	7.66	47,116	4.13	21,640	0	0	133,239	783,502	5,861,379	16.9
APR	30	654,000	87,440	3.48	21,396	4.94	25,935	47,150	189,119	-106,217	677,285	5,066,767	15.2
MAY	31	675,800	90,354	1.49	9,138	5.32	27,917	47,150	195,423	-123,847	553,438	4,140,267	13.1
JUN	30	654,000	87,440	0.41	2,496	4.66	24,448	47,150	189,119	-123,631	429,807	3,215,386	10.8
JUL	31	675,800	90,354	0.07	401	3.53	18,501	47,150	195,423	-123,168	306,639	2,293,966	8.3
AUG	30	654,000	87,440	0.12	758	2.08	10,902	47,150	189,119	-111,824	194,815	1,457,414	5.7
SEP	30	654,000	87,440	0.57	3,477	1.10	5,782	47,150	189,119	-103,984	90,832	679,513	2.9
OCT	31	675,800	90,354	2.97	18,231	0.72	3,799	47,150	195,423	-90,636	196	1,464	-0.1
<b>Totals:</b>		<b>8,569,400</b>	<b>1,145,729</b>	<b>60.31</b>	<b>370,823</b>	<b>33.1</b>	<b>173,614</b>	<b>10,090,100</b>	<b>1,342,742</b>	<b>196</b>	<b>4,651,534</b>	<b>34,798,128</b>	

Notes:

\*Evaporation rates at 0.8\*Pan A mean rate for Lake Lagunitas, 1987-1994, MMWD

Evap calculated based on water surface area at 50% pond capacity (vol)

Pond bottom area, SQ FT:

32,632

<b>Annual Recycled Water Volume:</b>	<b>10.09</b>	Mgal
	<b>30.97</b>	ac-ft

**WOODACRE - SAN GERONIMO WASTEWATER RECYCLDING STUDY**  
**BACK NINE LOWER POND WATER BALANCE FOR 10-YR. RAINFALL**

**Back Nine Lower Pond - 10-Year**

**WASTEWATER INFLOW** 7,800 GPD, Winter 6,500 GPD, Summer  
**POND WATERSHED AREA** 40,990 SQUARE FEET  
**AVERAGE BANK SLOPE** 2.00 :1  
**MAXIMUM VOLUME** 2,600,000 GALLONS  
 347,547 CUBIC FEET  
**MAXIMUM WATER DEPTH** 15.0 FEET  
**MAX DEPTH WITH 2-FT FREEBOARD** 2.0 FEET

Month	Days in Month	Wastewater Inflow		Precipitation		Evaporation		Recycled Water Produced		Volume Change ΔV (ft <sup>3</sup> )	Total Balance Volume		End Water Depth (ft)
		WW (gal)	(ft <sup>3</sup> )	P (in)	(ft <sup>3</sup> )	Eto (in)	(ft <sup>3</sup> )	Irr. (gpd)	(ft <sup>3</sup> )		V (ft <sup>3</sup> )	(gal)	
NOV	30	234,000	31,286	7.43	25,384	0.98	2,337	0	0	54,333	54,333	406,464	3.9
DEC	31	241,800	32,329	11.61	39,648	0.94	2,261	0	0	69,716	124,048	928,006	7.4
JAN	31	241,800	32,329	13.61	46,484	1.83	4,372	0	0	74,440	198,488	1,484,892	10.3
FEB	28	218,400	29,200	10.91	37,271	2.87	6,860	0	0	59,611	258,100	1,930,843	12.3
MAR	31	241,800	32,329	7.66	26,176	4.13	9,875	0	0	48,630	306,729	2,294,643	13.8
APR	30	195,000	26,072	3.48	11,887	4.94	11,835	16,500	66,182	-40,058	266,671	1,994,969	12.6
MAY	31	201,500	26,941	1.49	5,077	5.32	12,740	16,500	68,388	-49,110	217,561	1,627,577	11.0
JUN	30	195,000	26,072	0.41	1,387	4.66	11,157	16,500	66,182	-49,880	167,682	1,254,425	9.2
JUL	31	201,500	26,941	0.07	223	3.53	8,443	16,500	68,388	-49,667	118,014	882,866	7.1
AUG	30	195,000	26,072	0.12	421	2.08	4,975	16,500	66,182	-44,664	73,350	548,733	5.0
SEP	30	195,000	26,072	0.57	1,932	1.10	2,638	16,500	66,182	-40,817	32,533	243,383	2.6
OCT	31	201,500	26,941	2.97	10,129	0.72	1,734	16,500	68,388	-33,052	-519	-3,880	-0.1
<b>Totals:</b>		<b>2,562,300</b>	<b>342,580</b>	<b>60.31</b>	<b>206,018</b>	<b>33.1</b>	<b>79,228</b>	<b>3,514,500</b>	<b>469,889</b>	<b>-519</b>	<b>1,816,992</b>	<b>13,592,921</b>	

Notes:

\*Evaporation rates at 0.8\*Pan A mean rate for Lake Lagunitas, 1987-1994, MMWD

Evap calculated based on water surface area at 50% pond capacity (vol)

Pond bottom area, SQ FT:

11,200

<b>Annual Recycled Water Volume:</b>	<b>3.51</b>	Mgal
	<b>10.79</b>	ac-ft



**WOODACRE - SAN GERONIMO WASTEWATER RECYCLING STUDY  
BACK NINE UPPER POND WATER BALANCE FOR 10-YR. RAINFALL**

**Back Nine Upper Pond - 10-yr**

WASTEWATER INFLOW 10,200 GPD, Winter 8,500 gpd, Summer  
 POND WATERSHED AREA 48,960 SQUARE FEET  
 AVERAGE BANK SLOPE 2.00 :1  
**MAXIMUM VOLUME** 3,300,000 GALLONS  
 441,117 CUBIC FEET  
**MAXIMUM WATER DEPTH** 15.0 FEET  
**MAX DEPTH WITH 2-FT FREEBOARD** 2.0 FEET

Month	Days in Month	Wastewater Inflow		Precipitation		Evaporation		Recycled Water Produced		Volume Change ΔV (ft <sup>3</sup> )	Total Balance Volume		End Water Depth (ft)
		WW (gal)	(ft <sup>3</sup> )	P (in)	(ft <sup>3</sup> )	Eto (in)	(ft <sup>3</sup> )	Irr. (gpd)	(ft <sup>3</sup> )		V (ft <sup>3</sup> )	(gal)	
NOV	30	306,000	40,912	7.43	30,320	0.98	2,337	0	0	68,895	68,895	515,402	3.8
DEC	31	316,200	42,276	11.61	47,358	0.94	2,261	0	0	87,372	156,267	1,169,032	7.3
JAN	31	316,200	42,276	13.61	55,522	1.83	4,372	0	0	93,425	249,692	1,867,947	10.3
FEB	28	285,600	38,185	10.91	44,518	2.87	6,860	0	0	75,843	325,535	2,435,327	12.3
MAR	31	316,200	42,276	7.66	31,266	4.13	9,875	0	0	63,667	389,202	2,911,618	13.9
APR	30	255,000	34,094	3.48	14,198	4.94	11,835	21,600	86,638	-50,181	339,021	2,536,215	12.7
MAY	31	263,500	35,230	1.49	6,064	5.32	12,740	21,600	89,526	-60,971	278,049	2,080,088	11.1
JUN	30	255,000	34,094	0.41	1,656	4.66	11,157	21,600	86,638	-62,044	216,005	1,615,934	9.3
JUL	31	263,500	35,230	0.07	266	3.53	8,443	21,600	89,526	-62,472	153,533	1,148,579	7.2
AUG	30	255,000	34,094	0.12	503	2.08	4,975	21,600	86,638	-57,017	96,516	722,039	5.1
SEP	30	255,000	34,094	0.57	2,307	1.10	2,638	21,600	86,638	-52,875	43,641	326,479	2.6
OCT	31	263,500	35,230	2.97	12,098	0.72	1,734	21,600	89,526	-43,931	-290	-2,170	-0.1
<b>Totals:</b>		<b>3,350,700</b>	<b>447,989</b>	<b>60.31</b>	<b>246,076</b>	<b>33.1</b>	<b>79,228</b>	<b>4,600,800</b>	<b>615,127</b>	<b>-290</b>	<b>2,316,066</b>	<b>17,326,492</b>	

<b>Annual Recycled Water Volume:</b>	<b>4.60</b>	Mgal
	<b>14.12</b>	ac-ft

Notes:

\*Evaporation rates at 0.8\*Pan A mean rate for Lake Lagunitas, 1987-1994, MMWD  
 Evap calculated based on water surface area at 50% pond capacity (vol)  
 Pond bottom area, SQ FT: 14,316

# **Rainfall and Evaporation Reference Data**

<b>Monthly Rainfall for Woodacre (inches)</b>				
<b>Month</b>	<b>Average<sup>1</sup></b>	<b>10-year</b>	<b>50-year</b>	<b>100-year</b>
<b>Jan</b>	5.13	7.43	8.82	9.28
<b>Feb</b>	8.01	11.61	13.77	14.49
<b>Mar</b>	9.39	13.61	16.14	16.99
<b>Apr</b>	7.53	10.91	12.94	13.62
<b>May</b>	5.29	7.66	9.09	9.57
<b>Jun</b>	2.40	3.48	4.13	4.34
<b>Jul</b>	1.03	1.49	1.76	1.86
<b>Aug</b>	0.28	0.41	0.48	0.51
<b>Sep</b>	0.05	0.07	0.08	0.08
<b>Oct</b>	0.09	0.12	0.15	0.15
<b>Nov</b>	0.39	0.57	0.67	0.71
<b>Dec</b>	2.05	2.97	3.52	3.70
<b>Total</b>	<b>41.6</b>	<b>60.3</b>	<b>71.5</b>	<b>75.3</b>
<b>Multiplier<sup>2</sup></b>	1.00	1.45	1.72	1.81

Notes:

1. Woodacre Fire Station
2. Based on statistical analysis of historical records for San Rafael & Kentfield

<b>Estimated Pond Evaporation Rates</b>			
<b>Month</b>	<b>Pan A Data (MMWD)</b>		<b>Pond Evaporation @ 0.80 Coefficient*</b>
	<b>mm</b>	<b>inches</b>	
Jan	31	1.22	0.98
Feb	30	1.18	0.94
Mar	58	2.28	1.83
Apr	91	3.58	2.87
May	131	5.16	4.13
Jun	157	6.18	4.94
Jul	169	6.65	5.32
Aug	148	5.83	4.66
Sep	112	4.41	3.53
Oct	66	2.60	2.08
Nov	35	1.38	1.10
Dec	23	0.91	0.72
<b>Total</b>	<b>1,051</b>	<b>41.38</b>	<b>33.10</b>

\*Per NOAA Technical Report NWS-33, Map 4 – Pan Coefficients

Table 5

Monthly pan evaporation data provided by MMWD for two stations in the Tomales watershed; observation period is January 1987–December 1994

	Lake Nicasio			Lake Lagunitas		
	Mean (mm month <sup>-1</sup> )	SD (mm month <sup>-1</sup> )	% SD	Mean (mm month <sup>-1</sup> )	SD (mm month <sup>-1</sup> )	% SD
January	13	8	62	31	24	77
February	24	9	38	30	10	33
March	41	22	54	58	8	14
April	89	46	52	91	7	8
May	135	27	20	131	17	12
June	164	11	7	157	16	10
July	184	23	13	169	11	7
August	145	15	10	148	15	10
September	90	34	38	112	17	15
October	43	22	51	66	9	14
November	24	4	17	35	6	17
December	17	8	47	23	9	39

Source: Fischer, Douglas T., Stephen V. Smith & Robert R. Churchill. "Simulation of a century of runoff across the Tomales watershed, Marin County, California." Journal of Hydrology. 186 (1996) 253-273.

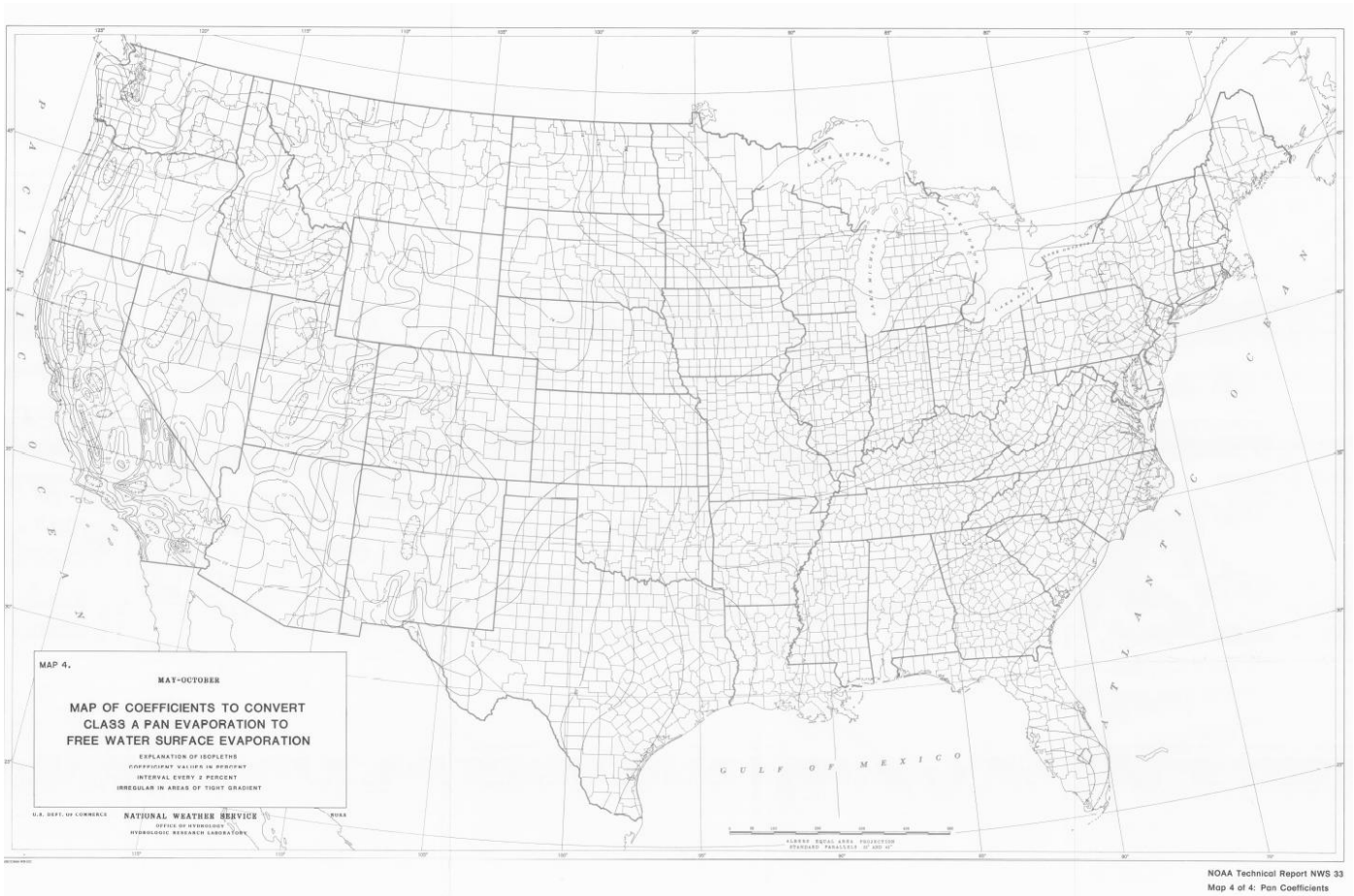

NOAA Technical Report NWS 33  
Map 4 of 4: Pan Coefficients



# **Rainfall Frequency Distribution**

## **Statistical Analysis**

Alpha (for confidence interval)

5.%

### Descriptive Statistics for Annual Precipitation Data: Kentfield, CA (Station 044500)

Count	76	Mean Deviation	12.42
Mean	46.14	Second Moment	255.1
Mean LCL	42.47	Third Moment	2,080.76
Mean UCL	49.82	Fourth Moment	240,734.09
Variance	258.5		
Standard Deviation	16.08	Sum	3,507.01
Mean Standard Error	1.84	Sum Standard Error	140.16
Coefficient of Variation	0.35	Total Sum Squares	181,217.92
		Adjusted Sum Squares	19,387.41
Minimum	7.8		
Maximum	94.38	Geometric Mean	43.12
Range	86.58	Harmonic Mean	39.26
		Mode	#N/A
Median	44.1		
Median Error	0.27	Skewness	0.51
Percentile 25% (Q1)	36.85	Skewness Standard Error	0.27
Percentile 75% (Q3)	56.56	Kurtosis	3.7
IQR	19.71	Kurtosis Standard Error	0.52
MAD (Median Absolute Deviation)	0.47	Skewness (Fisher's)	0.52
Coefficient of Dispersion (COD)	0.28	Kurtosis (Fisher's)	0.83

### Annual Precipitation Frequency Distribution: Kentfield, CA (Station 044500)

Bins	Count	Cumulative Count	Percent	Cumulative Percent
7 To 17.73	2.	2.	0.03	0.03
17.73 To 27.66	5.	7.	0.07	0.09
27.66 To 37.59	16.	23.	0.21	0.3
37.59 To 47.53	22.	45.	0.29	0.59
47.53 To 57.46	12.	57.	0.16	0.75
57.46 To 67.39	13.	70.	0.17	0.92
67.39 To 77.32	3.	73.	0.04	0.96
77.32 To 87.25	1.	74.	0.01	0.97
87.25 To 97.18	2.	76.	0.03	1.

### Annual Precipitation Frequency Distribution Kentfield, CA (Station 044500)

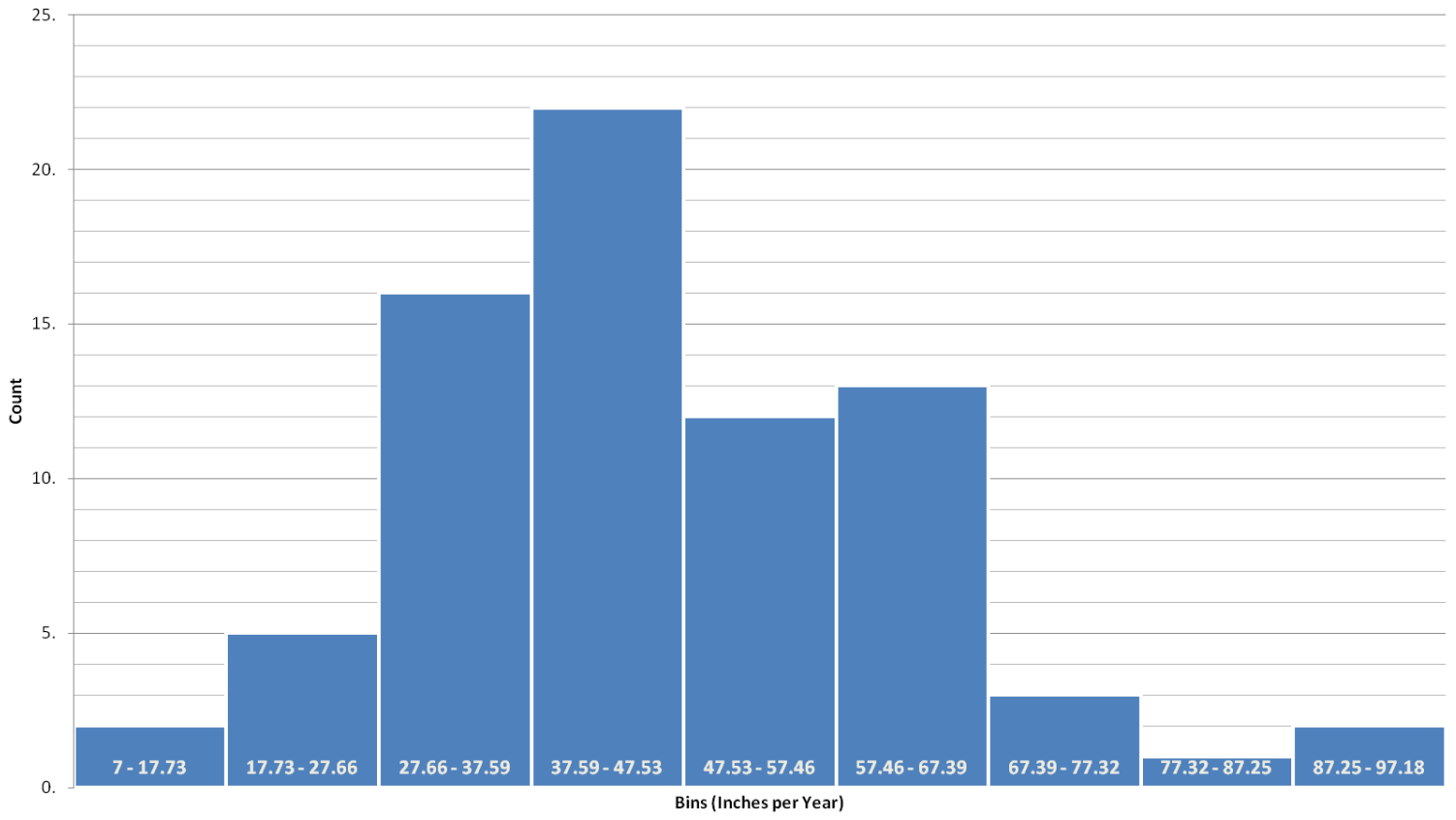

#### Annual Precipitation 100 Year Analysis: Kentfield, CA (Station 044500)

$$P(X \leq [Value]) = 0.99$$

where X is a given year's precipitation value, and P is the probability of that year's precipitation totals falling under some [Value] (the 100 year exceedance value) . For these data,

**[Value] = 83.55 inches/year** (100 year high, assuming normal distribution).



# Statistical Testing For Normality

## Kentfield, CA Annual Precipitation Data (Station 044500)

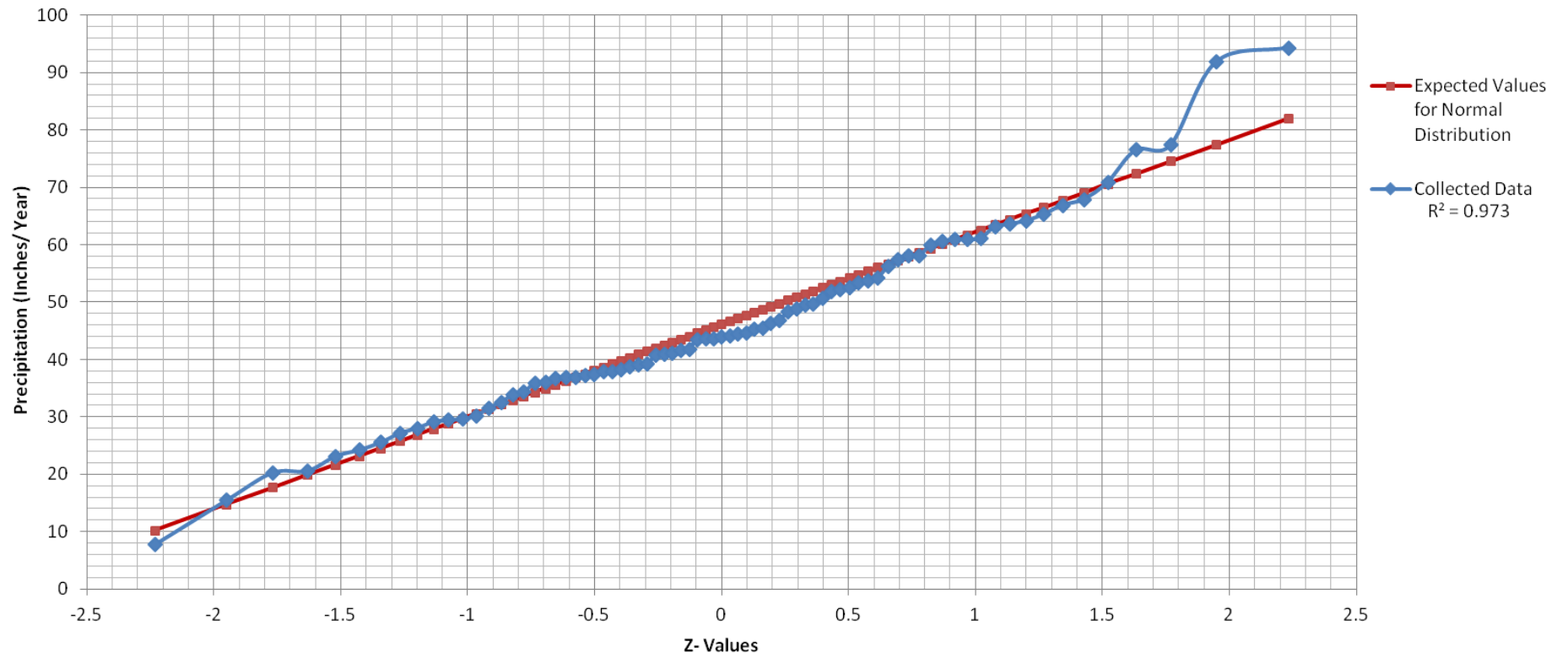

Alpha (for confidence interval)

5.%

**Descriptive Statistics for Annual Precipitation Data: San Rafael Civic Center, CA (Station 047880)**

Count	41	Mean Deviation	10.22
Mean	35.68	Second Moment	157.68
Mean LCL	31.66	Third Moment	72.27
Mean UCL	39.69	Fourth Moment	58,119.18
Variance	161.62		
Standard Deviation	12.71	Sum	1,462.78
Mean Standard Error	1.99	Sum Standard Error	81.4
Coefficient of Variation	0.36	Total Sum Squares	58,653.14
		Adjusted Sum Squares	6,464.71
Minimum	11.85		
Maximum	60.46	Geometric Mean	33.16
Range	48.61	Harmonic Mean	30.31
		Mode	#N/A
Median	35.52		
Median Error	0.39	Skewness	0.04
Percentile 25% (Q1)	27.36	Skewness Standard Error	0.36
Percentile 75% (Q3)	44.28	Kurtosis	2.34
IQR	16.92	Kurtosis Standard Error	0.67
MAD (Median Absolute Deviation)	20.4	Skewness (Fisher's)	0.04
Coefficient of Dispersion (COD)	0.29	Kurtosis (Fisher's)	-0.59

**Annual Precipitation Frequency Distribution: San Rafael Civic Center, CA (Station 047880)**

Bins	Count	Cumulative Count	Percent	Cumulative Percent
11 To 19.35	6.	6.	0.15	0.15
19.35 To 26.85	3.	9.	0.07	0.22
26.85 To 34.35	10.	19.	0.24	0.46
34.35 To 41.85	10.	29.	0.24	0.71
41.85 To 49.35	5.	34.	0.12	0.83
49.35 To 56.85	5.	39.	0.12	0.95
56.85 To 64.35	2.	41.	0.05	1.

### Annual Precipitation Frequency Distribution San Rafael Civic Center, CA (Station 047880)

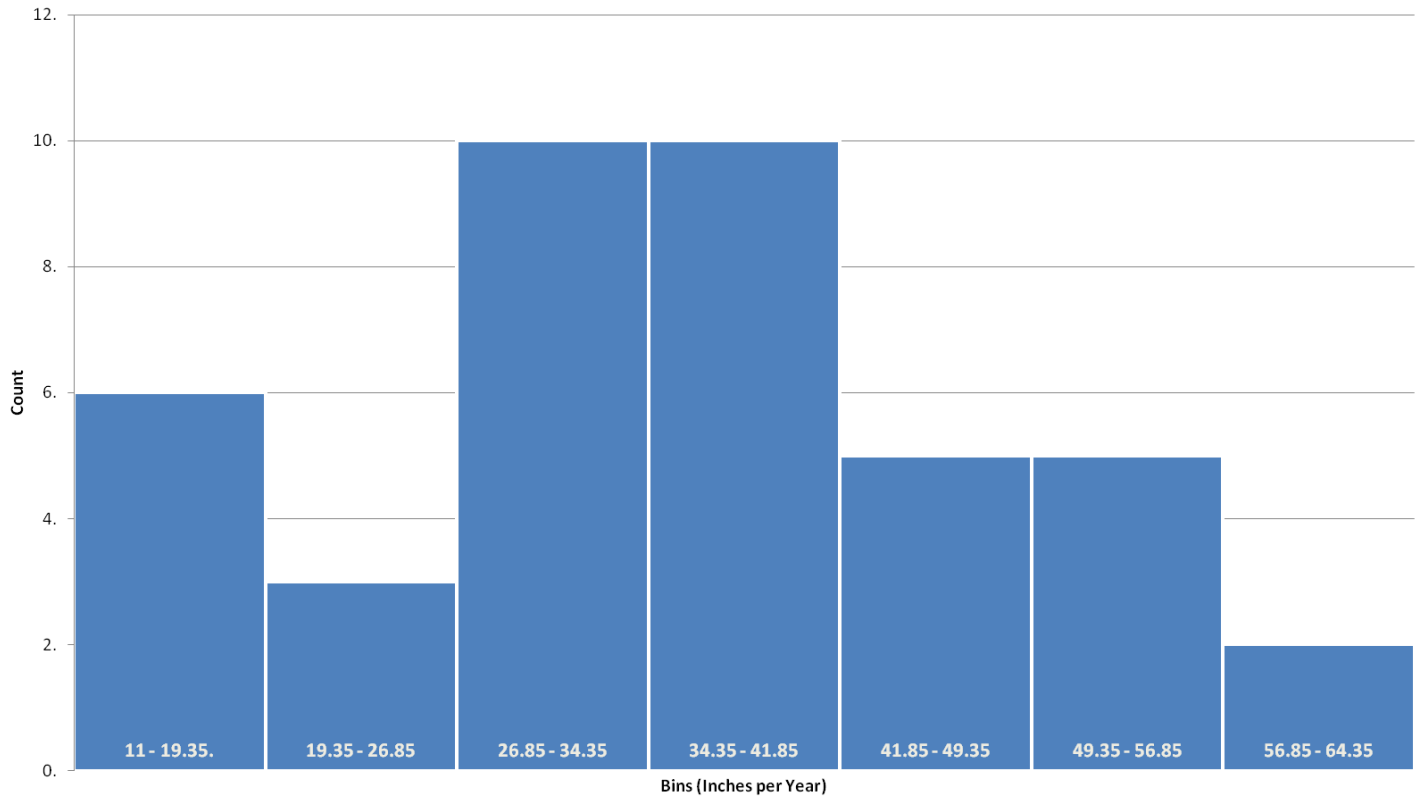

### Annual Precipitation 100 Year Analysis: Kentfield, CA (Station 044500)

$$P(X \leq [\text{Value}]) = 0.99$$

where X is a given year's precipitation value, and P is the probability of that year's precipitation totals falling under some [Value] (the 100 year exceedance value) . For these data,

**[Value] = 65.25 inches/year (100 year high).**

# Statistical Testing For Normality

## San Rafael Civic Center Annual Precipitation Data (Station 047880)

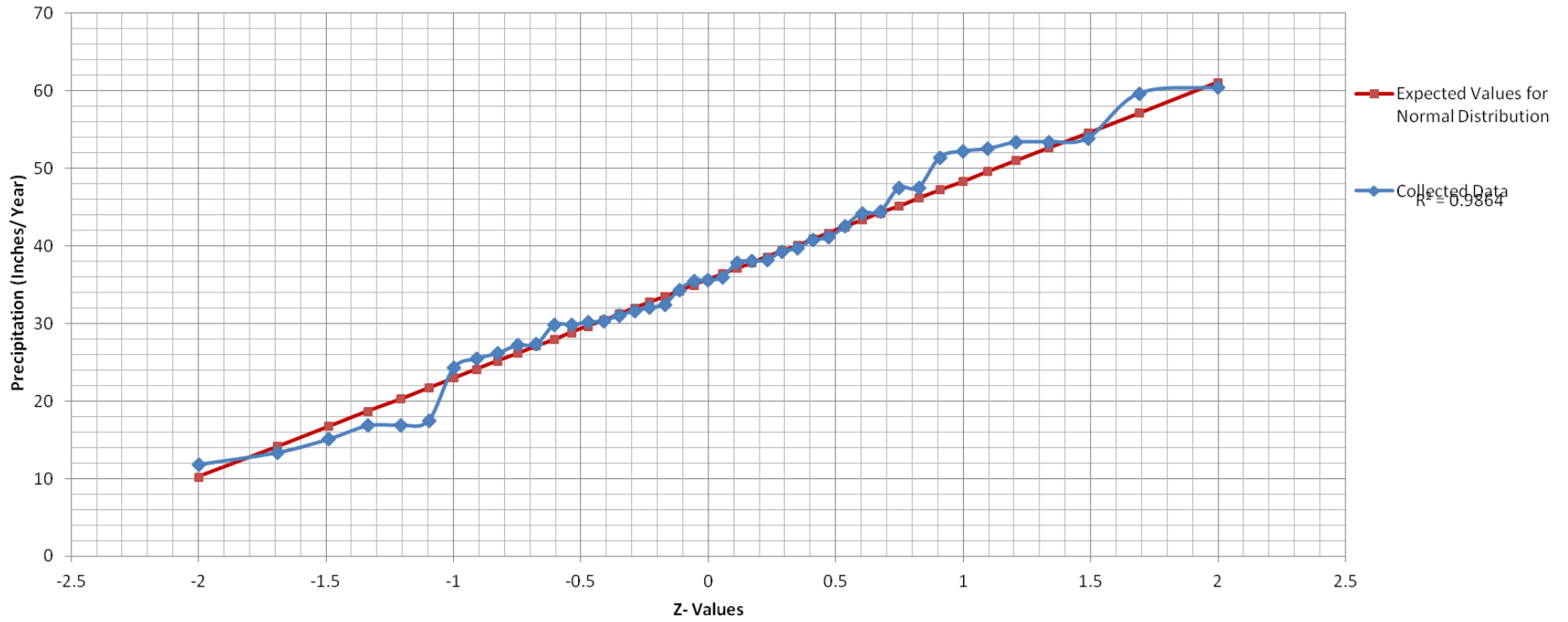

Appendix G

---

# Clubhouse Parcel Irrigation And Soils Information

## APPENDIX G CLUBHOUSE PARCEL IRRIGATION AND SOILS INFORMATION

### 1.0 SOILS INFORMATION

Provided here are the soils information from the Marin County Soil Survey, (NCSS, 1985). A site map is provided (**Figure F-1**) denoting the layout of the dripfield area and location of relevant site info including percolation tests and soil profiles. Percolation tests and soil profiles locations were recorded by Stuber-Stroeh Associates, Inc on plans dated July 16, 1991. Soils information for the two principal soils in the proposed dripfield area are listed below.

101 – Ballard gravelly, loam 2 to 9 percent slopes

- 0 – 19" Brown gravelly loam
- 19 – 65" Gravelly clay loam

105 – Blucher-Cole complex, 2 to 5 percent slopes

Blucher:

- 0 – 7" Silt loam
- 7 – 23" Loam, silt loam, fine sandy loam
- 23 – 60" Clay loam, silty clay loam

Cole:

- 0 – 5" Clay loam
- 5 – 14" Silty clay loam, clay loam, clay
- 14 – 60" Silty clay loam, clay loam, silty clay.



DATE:	2/26/2019
PROJECT:	WOODACRE WW
PROJECT NO.:	1600073
DRAWN:	MV
APPROVED:	NH



**DRIP DISPERSAL AREA  
&  
SOILS INFORMATION**

FIGURE  
**G-1**

**Irrigation Water Demand - Alt 5a**  
**Assumes 6.5 Acres; WW Flow at 26,000 gpd summer, 31,000 gpd winter**

Month	Ave Precip. (in/month)	Available Precip. (in/month)	Potential ET (in/month)	Estimated Irrigation Water Demand			Wastewater Flow		Surplus WW above Irrig Demand	Discharge to LF			Estimated Daily Irrigation w/Recycled Water (gpd)	Total Volume Recycled (gal)
				in/month	gallons/mo	gallons/day	Daily Average	Monthly Volume		Gal/Mo	Gal/MO	GPD		
Jan	9.39	8.45	1.86	0.00	0	0	31,000	961,000	961,000	961,000	31,000	0		
Feb	7.53	6.78	2.24	0.00	0	0	31,000	868,000	868,000	868,000	31,000	0		
Mar	5.29	4.76	3.41	0.00	0	0	31,000	961,000	961,000	961,000	31,000	0		
Apr	2.4	2.28	4.50	2.44	430,990	14,366	31,000	930,000	499,010	499,010	16,634	14,366	430,990	
May	1.03	1.03	5.27	4.66	823,152	26,553	26,000	806,000	-17,152	0	0	26,000	806,000	
Jun	0.28	0.28	5.70	5.96	1,052,237	35,075	26,000	780,000	-272,237	0	0	26,000	780,000	
Jul	0.05	0.05	5.89	6.42	1,133,776	36,573	26,000	806,000	-327,776	0	0	26,000	806,000	
Aug	0.09	0.09	5.58	6.04	1,065,827	34,382	26,000	806,000	-259,827	0	0	26,000	806,000	
Sep	0.39	0.39	4.50	4.52	797,914	26,597	26,000	780,000	-17,914	0	0	26,000	780,000	
Oct	2.05	1.95	3.41	1.61	283,929	9,159	31,000	961,000	677,071	677,071	21,841	9,159	283,929	
Nov	5.13	4.87	2.40	0.00	0	0	31,000	930,000	930,000	930,000	31,000	0		
Dec	8.01	7.21	1.86	0.00	0	0	31,000	961,000	961,000	961,000	31,000	0		
<b>Total</b>	<b>41.64</b>	<b>38.14</b>	<b>46.62</b>	<b>31.66</b>	<b>5,587,825</b>			<b>10,550,000</b>		<b>5,857,081</b>	<b>27,628</b>		<b>4,692,919</b>	

Notes:

1. Ave monthly precip for Woodacre Fire Station
  2. "Available Precip" equal to ave monthly precip minus runoff; assume runoff of 10% Dec-Feb; 10% Mar; 5% Apr, Oct, Nov; & no runoff during May-Sep dry season.
  3. Potential ET obtained from CIMIS for Zone 1, Coastal Plains & Heavy Fog Belt
  4. "Effective Water Demand" assumed to be 1.1 times Potential ET, to account for irrigation inefficiencies.
  5. Estimated Irrigation Required (in/month) equals demand minus available precip or equals zero if avail precip exceeds demand
- \* WW flows: 31K winter; 26K summer (ave)

Spray Field Acres:	6.5
--------------------	-----

**Recycled Water Volumes:**

1. Normal Year Irrigation of 6.5 acres, Apr-Oct	14.4 AF
2. Total Recycled w/Dry Apr and Oct	16.9 AF
3. Total Available Apr-Oct,	18.0 AF
3. Year-round total potentially available	32.4 AF



**Irrigation Water Demand - Alt 5b**  
**Assumes 7.0 Acres; WW Flow at 28,000 gpd summer, 33,200 gpd winter**

Month	Ave Precip. (in/month)	Available Precip. (in/month)	Potential ET (in/month)	Effective Irrigation Water Demand			Wastewater Flow		Surplus WW above Irrig Demand	Discharge to LF			Estimated Daily Irrigation w/Recycled Water (gpd)	Total Volume Recycled (gal)
				in/month	gallons/mo	gallons/day	Daily Average	Monthly Volume		Gal/Mo	Gal/MO	GPD		
Jan	9.39	8.45	1.86	0.00	0	0	33,200	1,029,200	1,029,200	1,029,200	33,200	0		
Feb	7.53	6.78	2.24	0.00	0	0	33,200	929,600	929,600	929,600	33,200	0		
Mar	5.29	4.76	3.41	0.00	0	0	33,200	1,029,200	1,029,200	1,029,200	33,200	0		
Apr	2.4	2.28	4.50	2.44	464,143	15,471	33,200	996,000	531,857	531,857	17,729	15,471	464,143	
May	1.03	1.03	5.27	4.66	886,472	28,596	28,000	868,000	-18,472	0	0	28,000	868,000	
Jun	0.28	0.28	5.70	5.96	1,133,178	37,773	28,000	840,000	-293,178	0	0	28,000	840,000	
Jul	0.05	0.05	5.89	6.42	1,220,989	39,387	28,000	868,000	-352,989	0	0	28,000	868,000	
Aug	0.09	0.09	5.58	6.04	1,147,813	37,026	28,000	868,000	-279,813	0	0	28,000	868,000	
Sep	0.39	0.39	4.50	4.52	859,292	28,643	28,000	840,000	-19,292	0	0	28,000	840,000	
Oct	2.05	1.95	3.41	1.61	305,770	9,864	33,200	1,029,200	723,430	723,430	23,336	9,864	305,770	
Nov	5.13	4.87	2.40	0.00	0	0	33,200	996,000	996,000	996,000	33,200	0		
Dec	8.01	7.21	1.86	0.00	0	0	33,200	1,029,200	1,029,200	1,029,200	33,200	0		
<b>Total</b>	<b>41.64</b>	<b>38.14</b>	<b>46.62</b>	<b>31.66</b>	<b>6,017,657</b>			<b>11,322,400</b>		<b>6,268,487</b>	<b>29,568</b>		<b>5,053,913</b>	

- Ave monthly precip for Woodacre Fire Station
  - "Available Precip" equal to ave monthly precip minus runoff; assume runoff of 10% Dec-Feb; 10% Mar; 5% Apr, Oct, Nov; & no runoff during May-Sep dry season.
  - Potential ET obtained from CIMIS for Zone 1, Coastal Plains & Heavy Fog Belt
    - "Effective Water Demand" assumed to be minus ppt, times 1.10 to account for irrigation inefficiencies.
  - Estimated Irrigation Required (in/month) equals demand minus available precip or equals zero if avail precip exceeds demand
- \* WW flows: 33.2K winter; 28K summer (ave)

Spray Field Acres:	7.0
--------------------	-----

Recycled Water Volumes:	
1. Normal Year Irrigation of 6.5 acres, Apr-Oct	15.5 AF
2. Total Recycled w/Dry Apr and Oct	18.2 AF
3. Total Available Apr-Oct,	19.4 AF
3. Year-round total potentially available	34.8 AF

**Irrigation Water Demand - Alt 5c**  
**Assumes 9.0 Acres; WW Flow at 37,000 gpd summer, 44,000 gpd winter**

Month	Ave Precip. (in/month)	Available Precip. (in/month)	Potential ET (in/month)	Effective Irrigation Water Demand			Wastewater Flow		Surplus WW above Irrig Demand	Discharge to LF		Estimated Daily Irrigation w/Recycled Water (gpd)	Total Volume Recycled (gal)
				in/month	gallons/mo	gallons/day	Daily Average	Monthly Volume		Gal/Mo	Gal/MO		
Jan	9.39	8.45	1.86	0.00	0	0	44,000	1,364,000	1,364,000	1,364,000	44,000	0	
Feb	7.53	6.78	2.24	0.00	0	0	44,000	1,232,000	1,232,000	1,232,000	44,000	0	
Mar	5.29	4.76	3.41	0.00	0	0	44,000	1,364,000	1,364,000	1,364,000	44,000	0	
Apr	2.4	2.28	4.50	2.44	596,755	19,892	44,000	1,320,000	723,245	723,245	24,108	19,892	596,755
May	1.03	1.03	5.27	4.66	1,139,749	36,766	37,000	1,147,000	7,251	7,251	234	36,766	1,139,749
Jun	0.28	0.28	5.70	5.96	1,456,943	48,565	37,000	1,110,000	-346,943	0	0	37,000	1,110,000
Jul	0.05	0.05	5.89	6.42	1,569,843	50,640	37,000	1,147,000	-422,843	0	0	37,000	1,147,000
Aug	0.09	0.09	5.58	6.04	1,475,760	47,605	37,000	1,147,000	-328,760	0	0	37,000	1,147,000
Sep	0.39	0.39	4.50	4.52	1,104,804	36,827	37,000	1,110,000	5,196	5,196	173	36,827	1,104,804
Oct	2.05	1.95	3.41	1.61	393,133	12,682	44,000	1,364,000	970,867	970,867	31,318	12,682	393,133
Nov	5.13	4.87	2.40	0.00	0	0	44,000	1,320,000	1,320,000	1,320,000	44,000	0	
Dec	8.01	7.21	1.86	0.00	0	0	44,000	1,364,000	1,364,000	1,364,000	44,000	0	
<b>Total</b>	<b>41.64</b>	<b>38.14</b>	<b>46.62</b>	<b>31.66</b>	<b>7,736,988</b>			<b>14,989,000</b>		<b>8,350,559</b>	<b>39,389</b>		<b>6,638,441</b>

Notes:

1. Ave monthly precip for Woodacre Fire Station
2. "Available Precip" equal to ave monthly precip minus runoff; assume runoff of 10% Dec-Mar; 5% Apr, Oct, Nov; & no runoff during May-Sep dry season.
3. Potential ET obtained from CIMIS for Zone 1, Coastal Plains & Heavy Fog Belt
  4. "Effective Water Demand" assumed to be minus ppt, times 1.10 to account for irrigation inefficiencies.
5. Estimated Irrigation Required (in/month) equals demand minus available precip or equals zero if avail precip exceeds demand

<b>Recycled Water Volumes:</b>	
1. Normal Year Irrigation of 6.5 acres, Apr-Oct	20.4 AF
2. Total Recycled w/Dry Apr and Oct	23.9 AF
3. Total Available Apr-Oct,	25.6 AF
3. Year-round total potentially available	46.0 AF

Spray Field Acres:	9.0
--------------------	-----

Appendix H

---

# Recycled Water Project Cost Estimates

**Preliminary Construction Cost Estimate**  
**Alternative 4a - Golf Course Water Recycling System, With Holding Pond #1**  
**Woodacre Only**

Treatment Design Flow - 30,000 gpd		Service Connections - 210 Woodacre Parcels		
Item	Units	No. of Units	Cost per Unit (\$)	Total Cost (\$)
<b>Title 22 Tertiary Treatment Plant</b>				
Influent EQ Tank and Pumps	Gal	15,000	4.00	\$60,000
1-day Emergency Storage Tank	Gal	35,000	4.00	\$140,000
30,000 GPD MBR Treatment Plant	LS	1	550,000.00	\$550,000
Disinfection System	LS	1	75,000.00	\$75,000
Odor Control	LS	1	20,000.00	\$20,000
Sludge Dewatering and Bagging System	LS	1	40,000.00	\$40,000
Effluent Pump Station	Gal	5,000	4.00	\$20,000
Electrical Service, Wiring and Controls	LS	1	60,000.00	\$60,000
Standby Emergency Generator	LS	1	50,000.00	\$50,000
Control Building/Office, Laboratory, Equip/Mtls Storage	SF	600	150.00	\$90,000
Grading, Surfacing, Fencing, Site Landscaping & Restoration	LS	1	75,000.00	\$75,000
<b>Treatment Subtotal</b>				<b>\$1,180,000</b>
<b>Recycled Water Transmission &amp; Storage</b>				
Transmission Line to Storage Pond #1	LF	1,800	50.00	\$90,000
Storage Pond Earthwork	CY	22,500	30.00	\$675,000
Storage Pond Liner	SF	100,000	1.00	\$100,000
Front Nine Pumping Station & Piping	LS	1	75,000.00	\$75,000
Fencing	LF	1,600	15.00	\$24,000
Turf and landscaping replanting, restoration	AC	1	40,000.00	\$40,000
<b>Disposal Subtotal</b>				<b>\$1,004,000</b>
			<b>Total</b>	<b>\$2,184,000</b>

Water Recycling Facilities - Alt 4a

**Capital Cost Summary**  
**Alternative 4a - Water Recycling Project, With Holding Pond #1**  
**Woodacre Only**

Treatment Design Flow - 30,000 gpd	Service Connections - 210 Woodacre	
Cost Item	Force Main Route A	Force Main Route B
Collection System - Woodacre*	\$4,063,175	\$4,067,575
Tertiary Treatment Plant	\$1,180,000	\$1,180,000
Recycled Water Storage & Transmission	\$1,004,000	\$1,004,000
Land/Easement Cost**	\$0	\$0
Mobilization/Demobilization	\$100,000	\$100,000
Permit Fees & Encroachment Fees	\$50,000	\$50,000
Sub-total	\$6,397,175	\$6,401,575
Contingency @ 15%	\$959,576	\$960,236
Sub-total	\$7,356,751	\$7,361,811
Engr & Environ Studies @ 15%	\$1,103,513	\$1,104,272
Construction Management @ 10%	\$735,675	\$736,181
Admin, Dist Formation, Financing @ 5%	\$367,838	\$368,091
Total Estimated Cost	\$9,563,777	\$9,570,355
Estimated Cost Per Connection*	\$45,542	\$45,573

\* owner cost for tank abandonment & plumbing connection not included; typical range \$1,500 to \$3,000 per parcel

\*\* assumes no land/easement cost for treatment/storage in exchange for golf course use of recycled water produced

**Preliminary Construction Cost Estimate**  
**Alternative 4b - Water Recycling Facilities, With Holding Ponds #1 & #2**  
**75% Partial Service - Woodacre and San Geronimo**

Design Flow - 35,000 gpd	Peak Flow - 50,000 gpd	Service Connections - 270 Parcels		
Item	Units	No. of Units	Cost per Unit (\$)	Total Cost (\$)
<b>Title 22 Tertiary Treatment Plant</b>				
Influent EQ Tank and Pumps	Gal	25,000	4.00	\$100,000
1-day Emergency Storage Tank	Gal	50,000	4.00	\$200,000
35,000 GPD MBR Treatment Plant	LS	1	600,000.00	\$600,000
Disinfection System	LS	1	75,000.00	\$75,000
Odor Control	LS	1	20,000.00	\$20,000
Sludge Dewatering and Bagging System	LS	1	40,000.00	\$40,000
Effluent Pump Station	Gal	5,000	4.00	\$20,000
Electrical Service, Wiring and Controls	LS	1	60,000.00	\$60,000
Standby Emergency Generator	LS	1	50,000.00	\$50,000
Control Building/Office, Laboratory, Equip/Mtls Storage	SF	600	150.00	\$90,000
Grading, Surfacing, Fencing, Site Improvements & Restoration	LS	1	75,000.00	\$75,000
<b>Treatment Subtotal</b>				<b>\$1,330,000</b>
<b>Recycled Water Transmission &amp; Storage</b>				
Transmission Line to Storage Ponds	LF	6,000	50.00	\$300,000
Storage Ponds Earthwork*	CY	27,000	30.00	\$810,000
Storage Pond Liners	SF	150,000	1.00	\$150,000
Pond underdrain system, Back Nine	SF	50,000	1.25	\$62,500
Drainage Modifications - Back Nine Pond	LF	700	75.00	\$52,500
Back Nine Irrigation Pump Station	LS	1	100,000.00	\$100,000
Front Nine Pumping Station	LS	1	20,000.00	\$20,000
Turf and landscaping replanting, restoration	AC	2.0	40,000.00	\$80,000
<b>Disposal Subtotal</b>				<b>\$1,575,000</b>
			<b>Total</b>	<b>\$2,905,000</b>

\* Pond #1 and Lower section of Pond #2

<b>Construction Cost Estimate</b>				
<b>Alternative4c - Water Recycling Facilities, With Holding Ponds #1 &amp; #2</b>				
<b>Full Service - Woodacre and San Geronimo</b>				
<b>Design Flow - 50,000 gpd</b>	<b>Peak Flow 60,000</b>	<b>Service Connections - 360 Parcels</b>		
<b>Item</b>	<b>Units</b>	<b>No. of Units</b>	<b>Cost per Unit (\$)</b>	<b>Total Cost (\$)</b>
<b>Title 22 Tertiary Treatment Plant</b>				
Influent EQ Tank and Pumps	Gal	30,000	4.00	\$120,000
1-day Emergency Storage Tank	Gal	60,000	4.00	\$240,000
50,000 GPD MBR Treatment Plant	LS	1	650,000.00	\$650,000
Disinfection System	LS	1	75,000.00	\$75,000
Odor Control	LS	1	30,000.00	\$30,000
Sludge Dewatering and Bagging System	LS	1	60,000.00	\$60,000
Effluent Pump Station	Gal	5,000	4.00	\$20,000
Electrical Service, Wiring and Controls	LS	1	60,000.00	\$60,000
Standby Emergency Generator	LS	1	50,000.00	\$50,000
Control Building/Office, Laboratory, Equip/Mtls Storage	SF	600	150.00	\$90,000
Grading, Surfacing, Fencing, Site Landscaping & Restoration	LS	1	75,000.00	\$75,000
<b>Treatment Subtotal</b>				<b>\$1,470,000</b>
<b>Recycled Water Transmission &amp; Storage</b>				
Transmission Line to Storage Ponds	LF	6,000	50.00	\$300,000
Storage Ponds Earthwork*	CY	33,000	30.00	\$990,000
Storage Pond Liners	SF	200,000	1.00	\$200,000
Pond underdrain system, Back Nine	SF	100,000	1.25	\$125,000
Drainage Modifications - Back Nine Pond	LF	1,200	75.00	\$90,000
Back Nine Irrigation Pump Station	LS	1	100,000.00	\$100,000
Front Nine Pumping Station	LS	1	20,000.00	\$20,000
Turf and landscaping replanting, restoration	AC	2.5	40,000.00	\$100,000
<b>Disposal Subtotal</b>				<b>\$1,925,000</b>
			<b>Total</b>	<b>\$3,395,000</b>

\*Recycled Water Storage Ponds #1 and #2

## Capital Cost Summary

### Alternatives 4b and 4c - Water Recycling Project, With Holding Ponds #1 & #2

#### 4b - Partial (75%) and 4c - Full (100%) Service to Woodacre and San Geronimo

Cost Item	Alternative 4b - 270 Parcels		Alternative 4c - 360 Parcels	
	Treatment Design Flow: 40,000 gpd		Treatment Design Flow: 50,000 gpd	
	Pressure Sewer	Cluster Gravity	Pressure Sewer	Cluster Gravity
<b>Collection System - Woodacre (Route A)</b>	\$3,921,375	\$3,921,375	\$4,224,175	\$4,224,175
<b>Collection System - San Geronimo</b>				
<b>Pressure Sewer</b>	\$1,486,800		\$1,811,800	
<b>Cluster Gravity/Pressure Sewer</b>		\$1,990,175		\$2,190,875
<b>Tertiary Treatment Plant</b>	\$1,330,000	\$1,330,000	\$1,470,000	\$1,470,000
<b>Recycled Water Storage &amp; Transmission</b>	\$1,575,000	\$1,575,000	\$1,925,000	\$1,925,000
<b>Land/Easement Costs*</b>	\$0	\$0	\$0	\$0
<b>Mobilization/Demobilization</b>	\$100,000	\$100,000	\$100,000	\$100,000
<b>Permit Fees &amp; Encroachment Fees</b>	\$50,000	\$50,000	\$50,000	\$50,000
<b>Sub-total</b>	<b>\$8,463,175</b>	<b>\$8,966,550</b>	<b>\$9,580,975</b>	<b>\$9,960,050</b>
<b>Contingency @ 15%</b>	\$1,269,476	\$1,344,983	\$1,437,146	\$1,494,008
<b>Sub-total</b>	<b>\$9,732,651</b>	<b>\$10,311,533</b>	<b>\$11,018,121</b>	<b>\$11,454,058</b>
<b>Engr &amp; Environ Studies @ 15%</b>	\$1,459,898	\$1,546,730	\$1,652,718	\$1,718,109
<b>Construction Management @ 10%</b>	\$973,265	\$1,031,153	\$1,101,812	\$1,145,406
<b>Admin, Dist Formation, Financing @ 5%</b>	\$486,633	\$515,577	\$550,906	\$572,703
<b>Total Estimated Cost</b>	<b>\$12,652,447</b>	<b>\$13,404,992</b>	<b>\$14,323,558</b>	<b>\$14,890,275</b>
<b>Estimated Cost Per Connection*</b>	<b>\$46,861</b>	<b>\$49,648</b>	<b>\$39,788</b>	<b>\$41,362</b>

\* owner cost for tank abandonment & plumbing connection not included; typical range \$1,500 to \$3,000 per parcel

\*\* assumes no land/eaement cost for treatment/storage in exchange for golf course use of recycled water produced



**Revised Construction Cost Estimate**  
**Alternative 5a - Water Recycling Facility, Without Holding Ponds**  
**Woodacre Only**

Treatment Design Flow - 35,000 gpd	Service Connections - 250 Woodacre Parcels			
Item	Units	No. of Units	Cost per Unit (\$)	Total Cost (\$)
<b>Title 22 Tertiary Treatment Plant</b>				
Influent EQ Tank and Pumps	Gal	15,000	4.00	\$60,000
1-day Emergency Storage Tank	Gal	40,000	4.00	\$160,000
30,000 GPD MBR Treatment Plant	LS	1	550,000.00	\$550,000
Disinfection System	LS	1	75,000.00	\$75,000
Odor Control	LS	1	35,000.00	\$35,000
Sludge Dewatering and Bagging System	LS	1	50,000.00	\$50,000
Electrical Service, Wiring and Controls	LS	1	60,000.00	\$60,000
Standby Emergency Generator	LS	1	75,000.00	\$75,000
Control Building/Office, Laboratory, Equip/Mtls Storage	SF	600	150.00	\$90,000
Screening/Building Shell, 40 x 80	SF	3,200	40.00	\$128,000
Grading, Drainage, Fencing, Site Landscaping & Restoration	LS	1	150,000.00	\$150,000
<b>Treatment Subtotal</b>				<b>\$1,433,000</b>
<b>Recycled Water Transmission and Dispersal</b>				
Gravity Transmission Line to Pump Station	LF	500	55.00	\$27,500
Joint Drip Field and Irrigation Dosing Tank, Pumps, Controls	LS	1	170,000.00	\$170,000
Supply and return lines to Drip Fields	LF	5,000	25.00	\$125,000
Winter Subsurface Drip Dispersal	LF	38,500	6.00	\$231,000
Cover fill	CY	1,440	50.00	\$72,000
Grading, Drainage, Site Landscaping & Restoration	LS	1	60,000.00	\$60,000
Irrigation Piping	AC	6.5	10,000.00	\$65,000
<b>Irrigation and Disposal Subtotal</b>				<b>\$750,500</b>
			<b>Total</b>	<b>\$2,183,500</b>

**Capital Cost Summary**  
**Alternative 5a - Water Recycling Project, Without Holding Ponds**  
**Woodacre Only**

Treatment Design Flow - 30,000 gpd	Service Connections - 250 Woodacre	
Cost Item	Force Main Route A	Force Main Route B
Collection System - Woodacre*	\$4,326,175	\$4,216,575
Tertiary Treatment Plant	\$1,433,000	\$1,433,000
Recycled Water - Winter Drip, Summer Irrigation	\$750,500	\$750,500
Land/Easement Cost**	\$0	\$0
Mobilization/Demobilization	\$100,000	\$100,000
Permit Fees & Encroachment Fees	\$50,000	\$50,000
Sub-total	\$6,659,675	\$6,550,075
Contingency @ 15%	\$998,951	\$982,511
Sub-total	\$7,658,626	\$7,532,586
Engr & Environ Studies @ 15%	\$1,148,794	\$1,129,888
Construction Management @ 10%	\$765,863	\$753,259
Admin, Dist Formation, Financing @ 5%	\$382,931	\$376,629
Total Estimated Cost	\$9,956,214	\$9,792,362
Estimated Cost Per Connection*	\$39,825	\$39,169

\* owner cost for tank abandonment & plumbing connection not included; typical range \$1,500 to \$3,000 per parcel

\*\* assumes no land/eaement cost for treatment/storage in exchange for irrigation use of recycled water produced

Water Recycling Alternative 5a

**Preliminary Construction Cost Estimate**  
**Alternative 5b - Water Recycling Facility, Without Holding Ponds**  
**75% Partial Service - Woodacre and San Geronimo**

Design Flow - 35,000 gpd	Peak Flow - 45,000 gpd	Service Connections - 270 Parcels		
Item	Units	No. of Units	Cost per Unit (\$)	Total Cost (\$)
<b>Title 22 Tertiary Treatment Plant</b>				
Influent EQ Tank and Pumps	Gal	20,000	4.00	\$80,000
1-day Emergency Storage Tank	Gal	45,000	4.00	\$180,000
35,000 GPD MBR Treatment Plant	LS	1	550,000.00	\$550,000
Disinfection System	LS	1	75,000.00	\$75,000
Odor Control	LS	1	35,000.00	\$35,000
Sludge Dewatering and Bagging System	LS	1	50,000.00	\$50,000
Electrical Service, Wiring and Controls	LS	1	60,000.00	\$60,000
Standby Emergency Generator	LS	1	75,000.00	\$75,000
Control Building/Office, Laboratory, Equip/Mtls Storage	SF	600	150.00	\$90,000
Screening/Building Shell, 40 x 80	SF	3,200	40.00	\$128,000
Grading, Surfacing, Fencing, Site Improvements & Restoration	LS	1	150,000.00	\$150,000
<b>Treatment Subtotal</b>				<b>\$1,473,000</b>
<b>Recycled Water Transmission and Dispersal</b>				
Gravity Transmission Line to Pump Station	LF	500	55.00	\$27,500
Joint Drip Field and Irrigation Dosing Tank, Pumps, Controls	LS	1	187,000.00	\$187,000
Supply and return lines to Drip Fields	LF	5,000	25.00	\$125,000
Winter Subsurface Drip Dispersal	LF	41,500	6.00	\$249,000
Cover Fill	CY	1,530	50.00	\$76,500
Grading, Drainage, Site Landscaping & Restoration	LS	1	65,000.00	\$65,000
Irrigation Piping	AC	7	10,000.00	\$70,000
<b>Irrigation and Disposal Subtotal</b>				<b>\$800,000</b>
			<b>Total</b>	<b>\$2,273,000</b>

Water Recycling Facilities - Alt 5b

Construction Cost Estimate				
Alternative 5c - Water Recycling Facility, Without Holding Ponds				
Full Service - Woodacre and San Geronimo				
Design Flow - 50,000 gpd	Peak Flow 60,000	Service Connections - 360 Parcels		
Item	Units	No. of Units	Cost per Unit (\$)	Total Cost (\$)
<b>Title 22 Tertiary Treatment Plant</b>				
Influent EQ Tank and Pumps	Gal	30,000	4.00	\$120,000
1-day Emergency Storage Tank	Gal	60,000	4.00	\$240,000
50,000 GPD MBR Treatment Plant	LS	1	650,000.00	\$650,000
Disinfection System	LS	1	75,000.00	\$75,000
Odor Control	LS	1	40,000.00	\$40,000
Sludge Dewatering and Bagging System	LS	1	60,000.00	\$60,000
Electrical Service, Wiring and Controls	LS	1	60,000.00	\$60,000
Standby Emergency Generator	LS	1	75,000.00	\$75,000
Control Building/Office, Laboratory, Equip/Mtls Storage	SF	600	150.00	\$90,000
Screening/Building Shell, 40 x 80	SF	3,200	40.00	\$128,000
Grading, Surfacing, Fencing, Site Landscaping & Restoration	LS	1	150,000.00	\$150,000
<b>Treatment Subtotal</b>				<b>\$1,688,000</b>
<b>Recycled Water Transmission and Dispersal</b>				
Gravity Transmission Line to Pump Station	LF	500	55.00	\$27,500
Joint Drip Field and Irrigation Dosing Tank, Pumps, Controls	LS	1	240,000.00	\$240,000
Supply and return lines to Drip Fields	LF	6,000	25.00	\$150,000
Winter Subsurface Drip Dispersal	LF	55,000	6.00	\$330,000
Cover Fill	CY	2,100	50.00	\$105,000
Grading, Drainage, Site Landscaping & Restoration	LS	1	80,000.00	\$80,000
Irrigation Piping	AC	9	10,000.00	\$90,000
<b>Irrigation and Disposal Subtotal</b>				<b>\$1,022,500</b>
			<b>Total</b>	<b>\$2,710,500</b>

Water Recycling Facilities - Alt 5b

**Alternatives 5b and 5c - Water Recycling Project, Without Holding Ponds**

**Partial (5b) and Full (5c) Service to Woodacre and San Geronimo**

Cost Item	Alternative 5a - 270 Parcels		Alternative 5b - 360 Parcels	
	Treatment Design Flow: 35,000 gpd		Treatment Design Flow: 50,000 gpd	
	Pressure Sewer	Cluster Gravity	Pressure Sewer	Cluster Gravity
<b>Collection System - Woodacre (Route B)</b>	\$3,913,775	\$3,921,375	\$4,216,575	\$4,224,175
<b>Collection System - San Geronimo</b>				
<b>Pressure Sewer</b>	\$1,486,800		\$1,956,800	
<b>Cluster Gravity/Pressure Sewer</b>		\$1,990,175		\$2,190,875
<b>Tertiary Treatment Plant</b>	\$1,473,000	\$1,330,000	\$1,688,000	\$1,470,000
<b>Recycled Water Storage &amp; Transmission</b>	\$800,000	\$1,575,000	\$1,022,500	\$1,925,000
<b>Land/Easement Costs*</b>	\$0	\$0	\$0	\$0
<b>Mobilization/Demobilization</b>	\$100,000	\$100,000	\$100,000	\$100,000
<b>Permit Fees &amp; Encroachment Fees</b>	\$50,000	\$50,000	\$50,000	\$50,000
<b>Sub-total</b>	<b>\$7,823,575</b>	<b>\$8,966,550</b>	<b>\$9,033,875</b>	<b>\$9,960,050</b>
<b>Contingency @ 15%</b>	\$1,173,536	\$1,344,983	\$1,355,081	\$1,494,008
<b>Sub-total</b>	<b>\$8,997,111</b>	<b>\$10,311,533</b>	<b>\$10,388,956</b>	<b>\$11,454,058</b>
<b>Engr &amp; Environ Studies @ 15%</b>	\$1,349,567	\$1,546,730	\$1,558,343	\$1,718,109
<b>Construction Management @ 10%</b>	\$899,711	\$1,031,153	\$1,038,896	\$1,145,406
<b>Admin, Dist Formation, Financing @ 5%</b>	\$449,856	\$515,577	\$519,448	\$572,703
<b>Total Estimated Cost</b>	<b>\$11,696,245</b>	<b>\$13,404,992</b>	<b>\$13,505,643</b>	<b>\$14,890,275</b>
<b>Estimated Cost Per Connection*</b>	<b>\$43,319</b>	<b>\$49,648</b>	<b>\$37,516</b>	<b>\$41,362</b>

\* owner cost for tank abandonment & plumbing connection not included; typical range \$1,500 to \$3,000 per parcel

\*\* assumes no land/easement cost for treatment/storage in exchange for golf course use of recycled water produced

## Estimation of Water Recycling Component of Project Costs

The project costs associated specifically with treatment and delivery of disinfected tertiary recycled water were determined as presented below, including both capital costs and annual operation and maintenance costs. A 30-year operating period was used for this analysis. This analysis was done for each of the six water recycling alternatives (4a-4c and 5a-5c).

### Treatment Facilities

Treatment costs specific and necessary to meet water recycling requirements were determined by identifying individual treatment components for the tertiary treatment processes over and above the basic wastewater treatment elements as contained in the non-water recycling Alternative 3 - Fire Road community treatment and leachfield system. These included all or portions of the following items:

- 1-day short-term emergency storage facilities
- MBR treatment unit
- UV disinfection system
- Sludge bagging facilities
- Odor control
- Electrical and control systems
- Standby generator

Additional capital costs for the above items, showing construction cost and additional percentage estimate (1.495 %) covering engineering, administration, and contingencies are given in the Table 1. The costs represent roughly one-third of the total treatment system costs.

**Table 1. Estimated Costs for Recycled Water Treatment (\$)**

Alternative	Construction	Total Cost*
4a	400,000	598,000
4b	450,000	672,750
4c	500,000	747,500
5a	400,000	598,000
5b	450,000	672,750
5c	500,000	747,500

\*including contingencies (15%), engineering and environ. (15%), construction management (10%), admin(5%)

## Pipelines and Storage Facilities

Capital costs for transmission lines and recycled water storage facilities were determined similar to the treatment costs, by identifying the specific project components and their associated cost. For all six alternatives, the pipeline costs included the force mains to the golf course property and distribution piping to deliver the recycled water to the storage facilities on the golf course property. Storage costs for Alternatives 4a-4c were the two holding ponds on the golf course; for Alternatives 5a – 5c, costs for buried storage tanks to regulate the supply of water for irrigation and other recycling uses. **Table 2** lists these cost items for each of the six alternatives.

**Table 1. Estimated Costs for Recycled Water Transmission and Storage (\$)**

Alternative	Transmission Facilities Costs	Storage Facilities Costs	Combined Pipelines and Storage	Total Cost*
4a	370,000	1,004,000	1,374,000	2,054,130
4b	370,000	1,575,000	1,945,000	2,907,775
4c	370,000	1,925,000	2,295,000	3,431,025
5a	460,000	130,000	590,000	882,050
5b	460,000	147,000	607,000	907,465
5c	460,000	200,000	660,000	986,700

\*including contingencies (15%), engineering and environ. (15%), construction management (10%), admin(5%)

## Operation and Maintenance

Operation and maintenance (O&M) costs over a 30-yr period were estimated by comparing the difference between O&M costs for water recycling alternatives and the non-water recycling Alternative 3. On the basis of design flow, the differential was taken to represent costs associated with water recycling. The annual costs were then converted to a present worth costs, based on a 30-yr operating period using a 5% discount rate.

## Cost per Acre-foot Estimate

**Table 3** presents the overall summary of recycled water costs aligned with the projected average annual water recycling volumes produced by each alternative.

**Table 3. Estimated Cost for Recycled Water, 30-yr Basis  
(2019 \$)**

Recycled Water Alternatives	Average Annual Recycled Water Produced	Capital Costs for Water Recycling Components		Annual Recycling O&M Cost Present Worth <sup>1</sup>	Total 30-yr Cost for Recycled Water Production	Estimated Recycled Water Cost per Acre-foot
		Tertiary Treatment Facilities	Pipelines & Storage			
<b>4a</b>	28.8	598,000	2,054,130	1,702,990	4,355,120	5,041
<b>4b</b>	37.6	672,750	2,907,775	2,024,382	5,604,907	4,969
<b>4c</b>	50.0	747,500	3,431,025	2,140,683	6,319,208	4,213
<b>5a</b>	18.0	598,000	882,050	2,305,620	3,785,670	7,011
	32.4					3,895
<b>5b</b>	19.4	672,750	907,465	2,418,320	3,998,535	6,870
	34.8					3,830
<b>5c</b>	25.6	747,500	986,700	2,760,187	4,494,387	5,852
	46.0					3,257

<sup>1</sup> Present worth calculated for 30 years at 5% discount rate.



Appendix I

---

# Climate Change Analysis

**Water Recycling Alternatives**  
**Projected 30-yr GHG Emissions, tons of CO<sub>2e</sub>**

Sources	Alternatives					
	4a	4b	4c	5a	5b	5c
Parcels served by Community Wastewater System	210	270	360	250	270	360
Remaining OWTS	150	90	0	110	90	0
<b>Construction Phase</b>						
Septic tank abandonment & sewer connection	363	467	622	432	467	622
Gravity sewers	594	594	594	594	594	594
Pressure sewers, force main, lift stations	64	106	106	67	123	123
Treatment Plant	55	69	91	64	70	91
Distribution pipelines and pump stations	13	37	37	10	11	14
Irrigation facilities	0	0	0	28	30	39
Sub-surface drip dispersal	0	0	0	60	65	83
Storage ponds	452	587	741	0	0	0
<b>Sub-total Construction</b>	<b>1,540</b>	<b>1,860</b>	<b>2,191</b>	<b>1,254</b>	<b>1,359</b>	<b>1,566</b>
<b>Operation &amp; Maintenance, 30 yrs</b>						
Wastewater collection system(electrical)	136	205	294	149	205	293
Wastewater treatment system (electrical)	2,785	3,439	4,418	3,214	3,409	4,329
Treatment plant emissions	19	24	32	23	24	32
Vehicles, maintenance, repair, monitoring	8	8	11	8	8	11
Sludge disposal	9	12	15	11	12	15
<b>Sub-total O&amp;M</b>	<b>2,956</b>	<b>3,687</b>	<b>4,770</b>	<b>3,405</b>	<b>3,658</b>	<b>4,680</b>
<b>Emissions from Remaining OWTS, 30 yrs</b>						
Woodacre and San Geronimo OWTS	1,798	1,079	0	1,319	1,079	0
<b>Reductions from Water Recycling, 30 yrs</b>						
Raw water supply transmission (electrical)	-438	-584	-1,252	-281	-303	-404
<b>Net 30-yr GHG Emissions, tons CO<sub>2e</sub></b>	<b>5,856</b>	<b>6,042</b>	<b>5,709</b>	<b>5,697</b>	<b>5,793</b>	<b>5,842</b>
<b>Net Emissions per Parcel, tons CO<sub>2e</sub></b>	<b>16.27</b>	<b>16.78</b>	<b>15.86</b>	<b>15.83</b>	<b>16.09</b>	<b>16.23</b>

### GHG Calculations - Water Recycling Alternative 4a

Item	GHG per unit lbs CO2	Alternative 4a	
		# of Units	CO2
<b>Construction</b>			
Septic tank abandonment & sewer connection	3,458	210	726,180
Gravity sewers	66,000	15.93	1,051,380
Manholes	3,400	40	136,000
Main lift station	8,000	1	8,000
Pressure sewers & force mains			
2" (per 1,000 ft)	7,931	675	5,353
3" (per 1,000 ft)	10,222	4,600	47,021
4" (per 1,000 ft)	12,792	5,850	74,833
Treatment plant	109,115	1	109,115
Transmission lines & Pump Station	17,632	1	17,632
Holding ponds	903,509	1	903,509
<b>Sub-total Construction</b>			<b>3,079,024</b>
			1,540
<b>Operation &amp; Maintenance, 30 yrs</b>		Annual lbs CO2	30-yr
Grinder pumps - electrical	40 at 86 lbs/yr	3,440	103,200
Main lift station - electrical	3600 kw-hr/yr	5,616	168,480
Wastewater treatment plant - electrical	106,500 kw-hr/yr	166,140	4,984,200
Irrigation pump stations	12,500 kw-hr/yr	19,500	585,000
Treatment plant emissions	1,260 lbs/yr	1,260	37,800
Vehicles, maintenance, repair, monitoring	vehicle emissions	510	15,300
Sludge disposal	vehicle emissions	600	18,000
			<b>5,911,980</b>
			2,956
<b>Remaining OWTS</b>	150 at 799 lbs/yr	119,850	<b>3,595,500</b>
			1,798
<b>Recycled water reductions (avoided raw water)</b>	18,700 kw-hr/yr	-29,200	<b>-876,000</b>
			-438
		<b>Total lbs</b>	<b>11,710,504</b>
		<b>Total tons</b>	5,855

<b>GHG Calculations - Water Recycling Alternative 4b</b>			
<b>Item</b>	<b>GHG per unit</b>	<b>Alternative 4b</b>	
		<b>lbs CO2</b>	<b># of Units</b>
<b>Construction</b>			
Septic tank abandonment & sewer connection	3,458	270	933,660
Gravity sewers	66,000	15.93	1,051,380
Manholes	3,400	40	136,000
Main lift station	8,000	1	8,000
Pressure sewers & force mains			
2" (per 1,000 ft)	7,931	4,615	36,602
3" (per 1,000 ft)	10,222	5,950	60,821
4" (per 1,000 ft)	12,792	9,050	115,768
Treatment plant	137,502	1	137,502
Transmission lines & Pump Station	64,715	1	64,715
Holding ponds	1,174,562	1	1,174,562
<b>Sub-total Construction</b>			<b>3,719,009</b>
			1,860
<b>Operation &amp; Maintenance, 30 yrs</b>		Annual lbs CO2	30-yr
Grinder pumps - electrical	110 at 86 lbs/yr	9,460	283,800
Main lift station - electrical	2700 kw-hr/yr	4,213	126,390
Wastewater treatment plant - electrical	130,700 kw-hr/yr	203,892	6,116,760
Irrigation pump stations	16,250 kw-hr/yr	25,350	760,500
Treatment plant emissions	1,620 lbs/yr	1,620	48,600
Vehicles, maintenance, repair, monitoring	vehicle emissions	510	15,300
Sludge disposal	vehicle emissions	600	18,000
			<b>7,369,350</b>
			3,685
<b>Remaining OWTS</b>	90 at 799 lbs/yr	71,900	<b>2,157,000</b>
			1,079
<b>Recycled water reductions (avoided raw water)</b>	24,960 kw-hr/yr	-38,938	<b>-1,168,140</b>
			-584
		<b>Total lbs</b>	<b>12,077,219</b>
		<b>Total tons</b>	6,039

<b>GHG Calculations - Water Recycling Alternative 4c</b>			
<b>Item</b>	<b>GHG per unit</b>	<b>Alternative 4c</b>	
		<b>lbs CO2</b>	<b># of Units</b>
			<b>CO2</b>
<b>Construction</b>			
Septic tank abandonment & sewer connection	3,458	360	1,244,880
Gravity sewers	66,000	15.93	1,051,380
Manholes	3,400	40	136,000
Main lift station	8,000	1	8,000
Pressure sewers & force mains			
2" (per 1,000 ft)	7,931	4,615	36,602
3" (per 1,000 ft)	10,222	5,950	60,821
4" (per 1,000 ft)	12,792	9,050	115,768
Treatment plant	137,502	1	181,934
Transmission lines & Pump Station	64,715	1	64,715
Holding ponds	1,174,562	1	1,481,755
<b>Sub-total Construction</b>			<b>4,381,854</b>
			2,191
<b>Operation &amp; Maintenance, 30 yrs</b>		Annual lbs CO2	30-yr
Grinder pumps - electrical	162 at 86 lbs/yr	14,018	420,540
Main lift station - electrical	3600 kw-hr/yr	5,616	168,480
Wastewater treatment plant - electrical	130,700 kw-hr/yr	261,300	7,839,000
Irrigation pump stations	21,250 kw-hr/yr	33,150	994,500
Treatment plant emissions	2,160 lbs/yr	2,160	64,800
Vehicles, maintenance, repair, monitoring	vehicle emissions	740	22,200
Sludge disposal	vehicle emissions	1,032	30,960
			<b>9,540,480</b>
			4,770
<b>Remaining OWTS</b>	0	0	<b>0</b>
			0
<b>Recycled water reductions (avoided raw water)</b>	53,520 kw-hr/yr	-83,491	<b>-2,504,730</b>
			-1,252
		<b>Total lbs</b>	<b>11,417,604</b>
		<b>Total tons</b>	5,709

### GHG Calculations - Water Recycling Alternative 5a

Item	GHG per unit lbs CO2	Alternative 5a	
		# of Units	CO2
<b>Construction</b>			
Septic tank abandonment & sewer connection	3,458	250	864,500
Gravity sewers	66,000	15.93	1,051,380
Manholes	3,400	40	136,000
Main lift station	8,000	1	8,000
Pressure sewers & force mains			
2" (per 1,000 ft)	7,931	675	5,353
3" (per 1,000 ft)	10,222	4,600	47,021
4" (per 1,000 ft)	12,792	5,850	74,833
Treatment plant	127,753	1	127,753
Irrigation dosing stations	19,865	1	19,865
Irrigation facilities	55,991	1	55,991
Drip Dispersal Facilities	119,816	1	119,816
<b>Sub-total Construction</b>			<b>2,510,513</b>
			1,255
<b>Operation &amp; Maintenance, 30 yrs</b>		Annual lbs CO2	30-yr
Grinder pumps - electrical	50 at 86 lbs/yr	4,300	129,000
Main lift station - electrical	3600 kw-hr/yr	5,616	168,480
Wastewater treatment plant - electrical	123,500 kw-hr/yr	192,660	5,779,800
Irrigation pump stations	14,000 kw-hr/yr	21,840	655,200
Treatment plant emissions	1,500 lbs/yr	1,500	45,000
Vehicles, maintenance, repair, monitoring	vehicle emissions	510	15,300
Sludge disposal	vehicle emissions	600	18,000
			<b>6,810,780</b>
			3,405
<b>Remaining OWTS</b>	110 at 799 lbs/yr	87,900	<b>2,637,000</b>
			1,319
<b>Recycled water reductions (avoided raw water)</b>	12,000 kw-hr/yr	-18,720	<b>-561,600</b>
			-281
		<b>Total lbs</b>	<b>11,396,693</b>
		<b>Total tons</b>	5,698

### GHG Calculations - Water Recycling Alternative 5b

Item	GHG per unit lbs CO2	Alternative 5b	
		# of Units	CO2
<b>Construction</b>			
Septic tank abandonment & sewer connection	3,458	270	933,660
Gravity sewers	66,000	15.93	1,051,380
Manholes	3,400	40	136,000
Main lift station	8,000	1	8,000
Pressure sewers & force mains			
2" (per 1,000 ft)	7,931	4,615	36,602
3" (per 1,000 ft)	10,222	5,950	60,821
4" (per 1,000 ft)	12,792	10,850	138,793
Treatment plant	140,120	1	140,120
Irrigation dosing stations	19,865	1	21,445
Irrigation facilities	55,991	1	60,470
Drip Dispersal Facilities	119,816	1	129,401
<b>Sub-total Construction</b>			<b>2,716,692</b>
			1,358
<b>Operation &amp; Maintenance, 30 yrs</b>		Annual lbs CO2	30-yr
Grinder pumps - electrical	110 at 86 lbs/yr	9,460	283,800
Main lift station - electrical	2700 kw-hr/yr	4,213	126,390
Wastewater treatment plant - electrical	130,700 kw-hr/yr	203,892	6,116,760
Irrigation pump stations	15,000 kw-hr/yr	23,400	702,000
Treatment plant emissions	1,600 lbs/yr	1,600	48,000
Vehicles, maintenance, repair, monitoring	vehicle emissions	510	15,300
Sludge disposal	vehicle emissions	780	23,400
			<b>7,315,650</b>
			3,658
<b>Remaining OWTS</b>	90 at 799 lbs/yr	71,910	<b>2,157,300</b>
			1,079
<b>Recycled water reductions (avoided raw water)</b>	12,960 kw-hr/yr	-20,218	<b>-606,540</b>
			-303
		<b>Total lbs</b>	<b>11,583,102</b>
		<b>Total tons</b>	5,792

<b>GHG Calculations - Water Recycling Alternative 5c</b>			
<b>Item</b>	<b>GHG per unit</b>	<b>Alternative 5b</b>	
		<b>lbs CO2</b>	<b># of Units</b>
			<b>CO2</b>
<b>Construction</b>			
Septic tank abandonment & sewer connection	3,458	360	1,244,880
Gravity sewers	66,000	15.93	1,051,380
Manholes	3,400	40	136,000
Main lift station	8,000	1	8,000
Pressure sewers & force mains			
2" (per 1,000 ft)	7,931	4,615	36,602
3" (per 1,000 ft)	10,222	5,950	60,821
4" (per 1,000 ft)	12,792	10,850	138,793
Treatment plant	140,120	1	182,169
Irrigation dosing stations	19,865	1	28,593
Irrigation facilities	55,991	1	77,827
Drip Dispersal Facilities	119,816	1	166,544
<b>Sub-total Construction</b>			<b>3,131,609</b>
			1,566
<b>Operation &amp; Maintenance, 30 yrs</b>		Annual lbs CO2	30-yr
Grinder pumps - electrical	162 at 86 lbs/yr	13,932	417,960
Main lift station - electrical	3600 kw-hr/yr	5,616	168,480
Wastewater treatment plant - electrical	167,500 kw-hr/yr	261,300	7,839,000
Irrigation pump stations	17,500 kw-hr/yr	27,300	819,000
Treatment plant emissions	2,160 lbs/yr	2,160	64,800
Vehicles, maintenance, repair, monitoring	vehicle emissions	740	22,200
Sludge disposal	vehicle emissions	1,032	30,960
			<b>9,362,400</b>
			4,681
<b>Remaining OWTS</b>	0	0	<b>0</b>
			0
<b>Recycled water reductions (avoided raw water)</b>	17,280 kw-hr/yr	-26,957	<b>-808,710</b>
			-404
		<b>Total lbs</b>	<b>11,685,299</b>
		<b>Total tons</b>	<b>5,843</b>



### Septic Tank Abandonment and Sewer Connection (Gravity or Grinder Pump)

Assume: pump-out, backfill tank, install 4" sewer line or pressure lateral to street sewer, 50 feet;							CO2, lbs	
Tank pump-out:	1200 gal at 8.35 lb/gal = 10,000 lbs = 5 tons;	60 mi at 0.5 lbs/ton-mi;	5*60 * 0.5 = 150 lbs				150	
Tank soil backfill	1200 gal/7.48 = 160 cu ft * 100 lbs per cu ft = 16,000 lbs = 8 tons	50 mi transport at 0.5 lbs per ton-mi = 200 lbs CO2					200	
Install	75 hp	Excavator/grader - 6 hrs operating	450 hp-hrs	691 g CO2/hp-hr	1.52 lbs/hp-hr	684	684	
	65 hp	Loader - 6 hrs operating	390 hp hrs	691 g CO2/hp-hr	1.52 lbs/hp-hr	592.8	593	
	150 hp	Dump truck - 8 hrs	1200 hp-hrs	691 g CO2/hp-hr	1.52 lbs/hp-hr	1824	1,824	
Laborers		Light Duty Trucks (2) at 15.7 g/mile	2 * 15.7 * 60 per day *1.5 days =	2,826 g CO2 /454 = 6.2			6.2	
Inspection		Vehicle at 12.4 g/mi	30 mi at 12.4 g/mi :	372 g/454 = 0.7 lbs per site			0.7	
<b>Total</b>							<b>lbs</b>	<b>3,458</b>
							<b>tons</b>	<b>1.73</b>

**GHG WORKSHEET - Gravity Sewer - PER 1,000 FEET - Installation at 200 feet per day**

Category	Item		Quantities					GHG	
Materials		GHG Factor	tons per 1,000 ft			GHG per 1,000 ft		Total lbs CO2 per 1,000 ft	
		lbs/lb	6"	8"		6"	8"	6"	8"
Pipe, HDPE	Production	3.03	2.49	4.22	0	15,089	25,573	15,089	25,573
	Transport - 100 miles	lbs/ton-mile	ton-miles						
0.5		249	422	0	124.50	211.00	125	211	
Soil & AB	Soil Off-haul & Import	lbs/ton-mile	miles	cubic feet	tons	ton-miles			
		0.5	100	10,000	500	50,000		25,000	25,000
Asphalt	Production	lbs/ton	tons per 1,000 ft						
		82.27	240	240		19,745	19,745	19,745	19,745
	Transport - 50 miles	lbs/ton-mile	tons	tons	miles	ton-miles	ton-miles		
		0.5	240	240	50	120	120	60	60
<b>Labor</b>	<b>Travel</b>	GHG Factor	miles/day	Days/1000 ft	Laborers	Total Miles	Total GHG		
	Crew	0.0345	60	5	6	1800	62.10	62	62
	Inspection	0.027	30	1	1	30	0.81	1	1
<b>Equipment</b>	<b>Type</b>	GHG Factor	Hp	Hrs per day	Days/1000 ft	GHG/1000 ft			
	Backhoe	1.52	95	6	5	4332		4,332	4,332
	Loader	1.52	65	6	5	2964		2,964	2,964
	Dump TruckS (2)	1.52	150	8	5	9120		9,120	9,120
	Roller	1.52	75	4	5	2280		2,280	2,280
	Paver	1.52	75	4	5	2280		2,280	2,280
							<b>Total, lbs</b>	<b>65,968</b>	<b>66,055</b>

**GHG Worksheet - Each SS Manhole**

Manholes	4' dia, 5-ft deep	GHG Factor	Quantities					GHG
Material	Concrete MH	lbs/ton	MH Weight , tons					lbs, CO2
	Production	1.94	4					8
	Transport	lbs/ton-mile	miles	ton-miles				
		0.5	100	400				200
Soil Off-haul	lbs/ton-mile	miles	cubic feet	tons	ton-miles			
	0.5	50	100	7.5	375		188	
Installation	Equipment	lbs/hp-hr	hp	hrs per MH	hp-hrs			
	Backhoe	1.52	95	8	760			1,155
	Dump Truck	1.52	150	8	1,200			1,824
	Travel	lbs/mi	miles/day	Days/manhole	Laborers	Total Miles	Total GHG	
	Crew	0.0345	60	2	4	480	16.56	17
	Inspection	0.027	30	1	1	30	0.81	1
						<b>Total, lbs</b>	<b>3,392</b>	

**GHG WORKSHEET - PRESSURE SEWER FORCE MAIN - PER 1,000 FEET - Installation at 800 feet per day**

Category	Item	GHG Factor	Quantities						Total lbs CO2e per 1,000 ft			
Materials			tons per 1,000 ft			GHG per 1,000 ft						
Pipe, HDPE		lbs/lb	2	3	4	2	3	4	2"	3"	4"	
	Production	3.03	0.32	0.695	1.145	1,939	4,212	6,939	1,939	4,212	6,939	
	Transport (100 miles)	lbs/ton-mile	ton-miles									
		0.5	32	69.5	114.5	16.00	34.75	57.25	16	35	57	
Excavations & Backfill	Soil & AB	Soil Off-haul & Import	lbs/ton-mile	miles	cubic feet	tons	ton-miles					
			0.5	100	2,480	124	12,400		6,200	6,200	6,200	
Re-surfacing	Asphalt	Production	lbs/ton	tons per 1,000 ft								
			82.27	19	19	1,563	1,563	1,563	1,563	1,563	1,563	
		Transport (50 miles)	lbs/ton-mile	tons	tons	miles	ton-miles	ton-miles				
		0.5	19	19	50	120	120	60	60	60		
Labor	Travel - Labor	lbs/mi	miles/day	Days/1000 ft	Laborers	Total Miles	Total GHG					
	Workers	0.0345	50	1.25	6	375	12.94		13	13	13	
	Inspection	0.027	30	1	1	30	0.81		1	1	1	
Equipment	Type	lbs/hp-hr	Hp	Hrs per day	Days/1000 ft	GHG/1000 ft						
	Drill Rig	1.52	150	6	1.25	1710			1,710	1,710	1,710	
	Backhoe	1.52	75	4	1.25	570			570	570	570	
	Loader	1.52	65	4	1.25	494			494	494	494	
	Utility Truck	1.52	120	4	1.25	912			912	912	912	
	Dump Truck	1.52	150	8	1.25	2280			2,280	2,280	2,280	
	Roller	1.52	75	4	1	456			456	456	456	
	Paver	1.52	75	4	1	456			456	456	456	
									<b>Total, lbs</b>	<b>13,819</b>	<b>13,838</b>	<b>13,860</b>

GHG Worksheet - Recycled Water Treatment Plant

Recycled Water Treatment Plant - Baseline - Alternative 5a, 250 parcels										Alt. 4a	Alt. 4b	Alt. 4c	Alt. 5b	Alt. 5c			
55,000 gallons of tanks x 1.5 over-excavation = 82,500 gal/7.48 = 11,000 cubic feet/27 = 400 cy										Alt 5a	at 0.85*5a	at 0.92*5a	at 1.44*5a	at 1.10*5a	at 1.44*5a		
Gravel surfacing and base rock: 5,400 sf * 0.5 = 2,700 cu ft = 100 cy;										Emissions	Emissions	Emissions	Emissions	Emissions			
Assumme 300 cy off-haul and 300 cy aggregate backfill : 300*1.3 tons/cy : 390 tons										lbs CO <sub>2</sub>	lbs CO <sub>2</sub>	lbs CO <sub>2</sub>	lbs CO <sub>2</sub>	lbs CO <sub>2</sub>			
400*1.3 = 520 tons																	
Gravel production 3.8 kg CO2 per tonne: 2.427*3.8: 9.22 lbs/ton; * 400 = 3,688 lbs										3,688	3,135	3,983	5,311	4,057	5,311		
Transport Med heavy truck at 225 g per ton-mile; 225/454 = 0.5 lbs/ton-mi; *50 mi = 13,000										13,000	11,050	14,040	18,720	14,300	18,720		
Soil Off-haul - assume 75% of gravel delivery										9,750	8,288	10,530	14,040	10,725	14,040		
Concrete																	
Production 40 cy*2 = 80 tons 1.94 lbs/ton 155 lbs										155	132	167	223	171	223		
Transport 80 tons 0.5*50*80 = 2000 lbs										2,000	1,700	2,160	2,880	2,200	2,880		
Asphalt										6,580	5,593	7,106	9,475	7,238	9,475		
Production 60 cy*1.3 = 80 tons 82.27 lbs/ton: 6,580 lbs CO2																	
Transport 0.5*50*80 = 2,000										2,000	1,700	2,160	2,880	2,200	2,880		
Soil & Sand - Biofilter, Landscaping 30 cy*1.3 = 40 tons at 0.5 lbs per ton-mile * 50 = 1,000 lbs CO2										1,000	850	1,080	1,440	1,100	1,440		
Misc Building Materials (piping, valves, lumber, electrical, etc) 10 tons*50* 0.5										250	125	125	125	275	360		
Treatment Plant																	
MBR - 30 tons, rail, 1,700 miles (Kansas to Sac) at 0.023 lbs per ton-mi: 30*1700*0.023 kg/ 2580.6										2,580	2,580	2,580	2,580	2,580	2,580		
Truck from Sac to Woodacre - 100 mi 30*100*0.5 lbs ton 1500										1,500	1,500	1,500	1,500	1,500	1,500		
Installation - 60 days																	
150 hp Excavator/grader -4 hrs/day for 10 days =40 hrs 6,000 hp-hrs 691 g CO2/hp-hr: 1.52 lbs/hp-hr										9120	7,752	9,850	13,133	10,032	13,133		
75 hp Excavator/grader -4 hrs/day for 30 days =120 hrs 9,000 hp-hrs 691 g CO2/hp-hr: 1.52 lbs/hp-hr										13680	11,628	14,774	19,699	15,048	19,699		
65 hp Loader -4hrs/day for 40 days =160 hrs 10,400 hp-hrs 691 g CO2/hp-hr: 1.52 lbs/hp-hr										15808	13,437	17,073	22,764	17,389	22,764		
150 hp Dump Truck - 8 hrs/day 20 days = 160 hrs 24,000 hp-hrs 691 g CO2/hp-hr: 1.52 lbs/hp-hr										36480	31,008	39,398	52,531	40,128	52,531		
75 hp Roller/Paver - 8 hrs/day 10 days = 80 hrs 6,000 hp-hrs 691 g CO2/hp-hr: 1.52 lbs/hp-hr										9120	7,752	9,850	13,133	10,032	13,133		
Workers: Light Duty Trucks (6) at 15.7 g/mile 6* 15.7 * 60 per day *60 d = 339120 75,360 g CO2 /454 = 165 lbs										747	635	807	1,076	822	1,076		
Inspection Passenger vehicle at 12.4 g/mile 1 * 12.4 * 60 per day *30 d = 133920 7,440 g CO2 /454 = 16.4 lbs										295	251	319	425	325	425		
										<b>Total</b>	<b>lbs CO<sub>2</sub></b>	<b>127,753</b>	<b>109,115</b>	<b>137,502</b>	<b>181,934</b>	<b>140,120</b>	<b>182,169</b>
										<b>tons</b>	<b>64</b>	<b>55</b>	<b>69</b>	<b>91</b>	<b>70</b>	<b>91</b>	

**GHG Worksheet - Holding Pond Construction**

<b>Holding Pond #1</b>								<b>Ponds #1 &amp; Lower #2</b>	<b>Ponds #1 &amp; #2</b>	
<b>Pond construction:</b>	22,500 cy earthwork				400 cy/day = 56 days construction period			<b>Vehicle Emissions lbs CO2</b>	27,000 cy;	33,000 cy
									72 days construction	92 days construction
									at 1.3 * Pond #1	at 1.64 * Pond #1
<b>Installation</b>	hp	hrs/day	days	hrs	hp-hrs	g CO2/hp-hr	lbs/hp-hr	<b>Vehicle Emissions</b>	<b>Vehicle Emissions</b>	
Bull dozer	300	6	56	360	108,000	691	1.52	164,160	213,408	269,222
Water truck	300	6	56	360	108,000	691	1.52	164,160	213,408	269,222
Grader	300	6	56	360	108,000	691	1.52	164,160	213,408	269,222
Roller	300	6	56	360	108,000	691	1.52	164,160	213,408	269,222
Excavator	150	6	56	360	54,000	691	1.52	82,080	106,704	134,611
Loader	150	6	56	360	54,000	691	1.52	82,080	106,704	134,611
Dump Truck	150	6	56	360	54,000	691	1.52	82,080	106,704	134,611
										0
Workers:	Light Duty Trucks (4) at 15.7 g/mile: 4* 15.7 * 60 mi/day *60 days: 226,080 g/454:							498	647	817
Inspection	Passenger vehicle at 12.4 g/mile; 1*12.4*60 mi/day*20 days: 59,520 g/454:							131	170	215
							<b>Total lbs</b>	<b>903,509</b>	<b>1,174,562</b>	<b>1,481,755</b>
							<b>tons</b>	<b>452</b>	<b>587</b>	<b>741</b>

**GHG Worksheet - Irrigation and Drip Dispersal - Alternatives 5a, 5b & 5c**

GHG Worksheet - Irrigation and Drip Dispersal - Baseline Alternative 5a										Alt 5b	Alt 5c			
Dosing Station										at 1.08*Alt 5a	at 1.44*Alt 5a			
40,000 gallons of tanks x 1.5 over-excavation =60,000 gal/7.48 = 8,021 cubic feet/27 = 297 cy										Emissions	Emissions	Emissions		
Assume 200 cy off-haul and 100 cy aggregate backfill :100*1.3 tons/cy : 130 tons										lbs CO2	lbs CO2	lbs CO2		
Gravel production	3.8 kg CO2 per tonne: 2.427*3.8:		9.22 lbs per	x 130=	1,199 lbs CO2 for gravel;					1,199	1,295	1,727		
Transport	Med heavy truck at 225 g per ton-mile		225/45 or 0.5 lbs per ton-mile:		times 50 mi*130 tons = 3,250 lbs CO2					3,250	3,510	4,680		
Soil Off-haul - assume 2 times value for gravel deliv:3,250 * 2 = 6,500										6,500	7,020	9,360		
Installation - 5 days														
75 hp	Excavator/grader -4 hrs/day for 10 days =40 hrs		3000 hp-hrs		691 g CO2/hp-hr : 1.52 lbs/hp-hr				2,280	2,462	3,283			
65 hp	Loader -4hrs/day for 10 days =40 hrs		2,600 hp-hrs		691 g CO2/hp-hr : 1.52 lbs/hp-hr				1,976	2,134	2,845			
150 hp	Dump Truck - 4 hrs/day 10 days = 40 hrs		6,000 hp-hrs		691 g CO2/hp-hr : 1.52 lbs/hp-hr				4,560	4,925	6,566			
Workers:	Light Duty Trucks (2) at 15.7 g/mile		4* 15.7 * 60 per day *10 d		37,680 g CO2 /454 = 42 lbs CO2				83	90	120			
Inspection	Passenger vehicle at 12.4 g/mile		1 * 12.4 * 60 per day *5 d		3,720 g CO2 /454 = 4.9 lbs CO2				8	9	12			
										Dosing Station	lbs	19,856	21,445	28,593
<b>Irrigation System - 6.5</b>										tons	10	11	14	
6.5 acres = 283,140 sf; piping at 12' o.c. = 23,600 lf; install at 4,000 lf per day = 6 days; 23,600 lf at 2" at 0.32 tons per 1,000 ft = 7.5 tons												at 1.08*Alt 5a	at 1.39*Alt 5a	
Irrigation & Distribution piping: 23,600 lf ave, 2 inch, at 2,000 lbs CO2/1,000 lf = 47,200 lbs CO2 (worksheet)										47,200	50,976	65,608		
Piping Transport	Med heavy truck at 225 g per ton-mile		225/454 or 0.5 lbs per ton-mile		x 50 mi*7.5 tons = 187.5 lbs CO2				188	203	261			
Installation:														
75 hp	Excavator/grader -4 hrs/day for 10 days =40 hrs		3000 hp-hrs		691 g CO2/hp-hr : 1.52 lbs/hp-hr				4,560	4,925	6,338			
65 hp	Loader -4hrs/day for 10 days =40 hrs		2600 hp-hrs		691 g CO2/hp-hr : 1.52 lbs/hp-hr				3,952	4,268	5,493			
Workers:	Light Duty Trucks (2) at 15.7 g/mile		4* 15.7 * 60 per day *10 days =		37,680 g CO2 /454 = 83 lbs CO2				83	90	115			
Inspection	Passenger vehicle at 12.4 g/mile		1 * 12.4 * 60 per day *5days =		3,720 g CO2 /454 = 8 lbs CO2				8	9	11			
										Irrigation	lbs	55,991	60,470	77,827
<b>Drip Dispersal Field - 1.8 acres</b>										tons	28	30	39	
38,500 lf dripline; 5,000 lf supply/return line; drainage - 1,500 lf; cover fill 1,450 cy;														
Cover Fill: 1,450 cy*1.3 = 1,900 tons												at 1.08*Alt 5a	at 1.39*Alt 5a	
Import Soil Transport	Med heavy truck at 225 g per ton-mile		225/454 or 0.5 lbs per ton-mile		x 50 mi*1,900 tons = 47,500 lbs CO2				47,500	51,300	66,025			
HDPE Irrigation Pipe 0.025 lbs per lf * 38,500 lf = 962 lbs; at 3.03 lbs CO2/lb = 2,916 lbs CO2 production; plus 1 ton transport: 0.5*100*1 = 50 lbs										2,966	3,203	4,123		
Distribution piping: 5,000 lf, 2" & 3" inch, at ave 3100 lbs CO2 per 1,000 lf =15,500 lbs CO2;										15,500	16,740	21,545		
Piping transport:	Med heavy truck at 225 g per ton-mile		225/454 or 0.5 lbs per ton-mile		x 100 mi*3.5 tons = 175 lbs CO2				175	189	243			
Installation														
75 hp	Excavator/grader -4 hrs/day for 20 days =80 hrs		6,000 hp-hrs		691 g CO2/hp-hr : 1.52 lbs/hp-hr				9,120	9,850	12,677			
65 hp	Loader -4hrs/day for 20 days =80 hrs		5,200 hp-hrs		691 g CO2/hp-hr : 1.52 lbs/hp-hr				7,904	8,536	10,987			
150 hp	Dump Truck - 8 hrs/day 20 days = 160 hrs		24,000 hp-hrs		691 g CO2/hp-hr : 1.52 lbs/hp-hr				36,480	39,398	50,707			
Workers:	Light Duty Trucks (2) at 15.7 g/mile		4* 15.7 * 60 per day *20 days =		75,360 g CO2 /454 =166 lbs CO2				166	179	231			
Inspection	Passenger vehicle at 12.4 g/mile		1 * 12.4 * 60 per day *10 days =		7,440 g CO2 /454 = 16 lbs CO2				5	5	7			
										Drip Field	lbs	119,816	129,401	166,544
										tons	60	65	83	

**Non Water Recycling Alternatives**  
**Projected 30-yr GHG Emissions, tons of CO<sub>2</sub>e**

Sources	Alternatives		
	1 - No Project	2 - Onsite Mgt.	3 - Fire Road
Parcels served by Community System	0	0	176
Remaining OWTS	360	360	184
<b>Construction Phase</b>			
OWTS septic tank replacement/upgrade	10.7	21.3	0
OWTS dispersal system replacement /upgrade	303	606	0
STEG & STEP tanks	0	0	82.5
Effluent sewers	0	0	63.6
Main lift station	0	0	4.0
Treatment Plant	0	0	41.5
Force main to leachfield	0	0	6.6
Community leachfield	0	0	41.4
<b>Sub-total Construction</b>	<b>314</b>	<b>627</b>	<b>240</b>
<b>Operation &amp; Maintenance, 30 yrs</b>			
Septic tank emissions (methane, CO <sub>2</sub> e)	2,678	2,678	1,309
Wastewater collection electrical	0	0	23
Treatment & dispersal electrical	0	216	1,473
Vehicles, maintenance, repair, monitoring	2	9	2
Septage, sludge disposal	226	226	104
<b>Sub-total O&amp;M</b>	<b>2,956</b>	<b>3,687</b>	<b>2,911</b>
<b>Emissions from Remaining OWTS, 30 yrs</b>			
Woodacre and San Geronimo OWTS	(above)	(above)	<b>2,206</b>
<b>Net 30-yr GHG Emissions, tons CO<sub>2</sub>e</b>	<b>3,270</b>	<b>4,315</b>	<b>5,357</b>
<b>Net Emissions per Parcel, tons CO<sub>2</sub>e</b>	<b>9.08</b>	<b>11.99</b>	<b>14.88</b>

Assumptions:

Alt 1 No Project: 40% of OWTS upgraded voluntarily; 20% with advanced treatment/pump systems

Alt2 Onsite Mgt: 80% of OWTS upgraded; 80% with advanced treatment/pump systems

**GHG WORKSHEET - OWTS Replacement - Low Level Upgrade - Trench Addition or curtain drain 50 feet**

<b>Category</b>	<b>Item</b>						<b>Total GHG, lbs CO2</b>
<b>Materials</b>		GHG Factor	1.5x3				
	<b>Gravel</b>	lbs/ton	cu-ft/lf	lf	cy	tons	
	Production	9.22	4.5	50	8.33	10.83	100
	Transport - 50 miles	lbs/ton-mile	ton-miles				
		0.5	704.17				352
<b>Vehicles</b>	<b>Travel</b>	GHG Factor	miles/day	Days	Laborers	Total Miles	
	<b>Laborers</b>	0.027	50	2	2	200	5
	<b>Design, Inspection</b>	0.027	50	3	1	150	4
<b>Equipment</b>	<b>Type</b>	GHG Factor	Hp	Hrs per day	Days	GHG/1000 ft	
	Dump, Haul Truck	1.52	100	4	2	1216	1,216
	Backhoe	1.52	100	2	2	608	608
	Loader	1.52	100	2	2	608	608
						<b>Total</b>	<b>2,893</b>





### GHG WORKSHEET - OWTS Replacement - High Level Upgrade - Tank, Treatment & Leachfield 200 lf

Category	Item						Total GHG, lbs CO2
<b>Materials</b>		GHG Factor	Tank Size	Tank Wt			
	<b>Tank</b>	lbs/ton	Gal	lbs	tons		
	Concrete	1.94	1,200	11,000	5.5		11
	Transport	lbs/ton-mile	miles				
		0.5	50				138
	<b>Treatment Equipment</b>						
		lbs/ton-mile	miles	tons			
	Transport	0.5	100	1			50
	<b>Gravel</b>	lbs/ton	cu-ft/lf	lf	cy	tons	
	Production	9.22	4.5	200	33.33	43.33	400
	Transport - 50 miles	lbs/ton-mile	ton-miles				
		0.5	2816.67				1,408
<b>Labor</b>	<b>Travel</b>	GHG Factor	miles/day	Days	Laborers	Total Miles	
	<b>Laborers</b>	0.027	50	5	2	500	14
	<b>Design, Inspection</b>	0.027	50	6	1	300	8
<b>Equipment</b>	<b>Type</b>	GHG Factor	Hp	Hrs per day	Days	GHG/1000 ft	
	Dump, Haul Truck	1.52	100	5	4	3040	3,040
	Backhoe	1.52	100	6	4	3648	3,648
	Loader	1.52	100	3	4	1824	1,824
						<b>Total</b>	<b>10,540</b>

## **GHG Emissions – Literature and Reference Data**

1. Leverenz, Harold, et al. 210. “Evaluation of Greenhouse Gases from Septic Systems. Final Report. Water Environment Federation.  
<http://www.decentralizedwater.org/documents/DEC1R09/DEC1R09.pdf>
2. Mannina, G. et al. 2018. “Greenhouse Gas Emissions from Membrane Bioreactors”. Water Science and Technology. Vol 78, Issue 4.
3. Ying-Chu Chien. 2019. “Estimation of greenhouse gas emissions from a wastewater treatment plant using membrane bioreactor technology”. Water Environment Research. 91(2), 111-118, 2019. <https://onlinelibrary.wiley.com/doi/abs/10.1002/wer.1004>
4. U.S. EPA. Emission Factor Documentation for AP-42, Section 11.19.1. Sand and Gravel Processing; Final Report. April 1995.  
<https://www3.epa.gov/ttnchie1/ap42/ch11/bgdocs/b11s19-1.pdf>

Appendix J

---

# Institutional Alternatives Review

## APPENDIX J

### INSTITUTIONAL ALTERNATIVES

#### Introduction

The implementation of a community wastewater recycling project in the Woodacre-San Geronimo area would require the formation of or annexation to a public district that has suitable powers and authority for operation and management of public sewers. This is required as a matter of public policy and also to enable the community to obtain and utilize various forms of public financial assistance available from the State and Federal government.

Provided here is a brief overview of the potential options available along with some of the key considerations that may influence the local decision on an appropriate institutional arrangement for the community. In general, all options presented here are technically viable; the ultimate decision by the community would likely focus on issues of local autonomy, economics and possibly political or personal preferences.

#### Existing Institutions

The present wastewater feasibility study is being conducted by the County of Marin, which has general authority for wastewater management throughout the unincorporated area of the County. Acting in this general capacity, the County has the authority to continue through the design and construction phase of the project, if this is desired. This is the approach that was followed for the Marshall Community Wastewater System, Phase 1 and Phase 2. However, ultimately a district would be needed for the operation and maintenance of the facilities that are constructed or for the governance of an onsite wastewater management program, if implemented for all or any portion of the study area.

Presently, there are two local districts with sewerage powers that encompass or are in reasonable proximity to the study area: (1) Marin Municipal Water District (MMWD) and (2) Ross Valley Sanitary District (RVSD). MMWD provides water service to the area, and has the authority to expand its scope of activities to include wastewater services. However, this would be a significant departure from existing MMWD operations and, based on preliminary inquiries during the 2011 Woodacre Flats wastewater study, MMWD has not indicated strong interest in taking on sewer service responsibilities. The RVSD operates an extensive sewer collection system with sewer service boundaries that extend to Fairfax. RVSD has the capabilities to provide wastewater service for a project in Woodacre-San Geronimo; however, its boundaries would have to be extended into the San Geronimo Valley through annexation. Thus far no inquiry has been made into the potential interest of RVSD in expanding their service area and activities to encompass a community wastewater project in Woodacre-San Geronimo.

## Independent Local Districts

Independent local districts are those formed to carry out a specific local public function, where the administration and decision-making is entrusted to a locally elected Board of Directors. This board assumes the responsibility for all policy, staffing and fiscal matters for the properties within the district. The boundaries of the district are established to encompass the areas benefiting from the district facilities or activities. Common types of independent local districts pertinent to the provision of sewerage services include:

- **Community Services District (CSD).** These districts have the authority to provide a broad range of public services, including police and fire protection, recreation and lighting, as well as water and sewer service. The formation of a CSD is initiated by local initiative; i.e., petition to the Board of Supervisors. An election is required for district formation and for election of the Board of Directors. The election can be waived if the petition includes at least 80 percent of the registered voters in the proposed district. There are no existing CSDs in the San Geronimo Valley. However, there are other CSDs in West Marin, e.g., Tomales Village CSD, which operates the community's wastewater collection, treatment and disposal facilities.
- **County Water Districts.** These local districts, authorized under the California Water Code, are formed in a similar manner to CSDs. But their powers are limited to provision of water and sewer service within their boundaries. Stinson Beach County Water District (SBCWD) is an example of this type of district. The SBCWD, with a locally elected board of directors, provides water service and also manages the onsite wastewater management program for the entire Stinson Beach community. Marin Municipal Water District is another example of a County Water District, which supplies water to the majority of the population in Marin County, including incorporated and unincorporated areas.
- **Sanitary Districts.** These districts are authorized under the Health and Safety Code specifically for the provision of sewage collection, treatment and disposal services. They can also provide water service. They are formed in a manner similar to CSDs and County Water Districts. The governing board of a Sanitary District is locally elected. Presently, there are no Sanitary Districts or County Sanitation Districts in West Marin. However, there are several sanitary districts throughout other parts of the County, such as the Ross Valley Sanitary District, Novato Sanitary District, and Las Gallinas Sanitary District.
- **Public Utility Districts.** These districts are authorized under the State Public Utilities Code and can provide a wide range of utility services, including sewer and water service. Public Utility Districts (PUD) can only be formed in unincorporated areas. They are governed by a locally elected board consisting of either three or five members. Inverness PUD and Bolinas Community PUD are local examples of PUDs in Marin County. Both of these districts provide water service within their districts; Bolinas Community PUD also owns and operates community sewerage facilities serving the downtown area of Bolinas.

Some of the common advantages of independent local districts include: (1) local autonomy in the decision-making process; and (2) local accountability and control over costs. The disadvantages of independent local districts may include: (1) limited financial resources and leverage; (2) limited economies of scale; and (3) limited resources and ability to meet public service demands. However, as in the case of MMWD and RVSD, independent water and wastewater districts can be large enough to encompass multiple jurisdictions and overcome economy of scale limitations.

## County-Dependent Districts

This category encompasses those districts formed and administered as sub-sets of County government. The County Board of Supervisors serves as the governing body or decision-maker for these districts. The Board of Supervisors acts as the Board of Directors for various dependent districts. As such, they assume responsibility for all policy, staffing, debt and rate structures within the boundaries of the district.

Marin County utilizes dependent districts to provide such things as sewer maintenance, landscape maintenance, lighting, recreation, fire protection, drainage and paramedic services. Marin County Counsel provides legal service. The Board of Supervisors typically works with a Citizen's Advisory Committee within each of the dependent districts to provide an opportunity for local input to the decision-making process.

Examples of County-dependent districts in Marin County include the following:

- **County Service Areas (CSA).** County service areas are much the same as CSDs in their range of authority. The key distinction is the governing body, which is the Board of Supervisors for all CSAs. They can be formed by either local petition or by a resolution of the Board of Supervisors. Presently, there are 16 CSAs in Marin County providing a variety of public services, ranging from park and open space management to drainage maintenance. There are currently no existing CSAs in Marin County that provide sewer services. However, in neighboring Sonoma County, a county-wide CSA, with multiple zones of benefit, is used to provide wastewater treatment and disposal services for several unincorporated communities.
- **Sanitation Districts.** These districts are authorized under the Health and Safety Code specifically for the provision of sewage collection, treatment and disposal services. They can also provide water service. It can include unincorporated and incorporated areas; its governing board is made of County Board of Supervisors and/or City Council members, depending upon the makeup of the district. A sanitation district may be formed upon local petition and Board approval. San Rafael Sanitation District is currently the only County Sanitation District in Marin County; it was formed to manage the sewer collection system for the San Quentin area.
- **Onsite Wastewater Management Districts.** The concept of public management of onsite wastewater disposal was developed in California in the mid-1970s to expand wastewater options in rural and suburban communities, specifically by providing a means

for more effective planning, operation and maintenance of onsite systems. The enabling legislation, Senate Bill 430, became law in January 1978 and was added to the California Health and Safety Code, commencing with Section 6950. This legislation enables public agencies that have powers to manage sewerage systems to form, under certain specified conditions, Onsite Wastewater Disposal Zones (Zones) in order to provide for the collection, treatment, reclamation or disposal of wastewater without the use of community-wide sanitary sewers or sewage systems. Such Zones may also manage community collection, treatment, disposal and water recycling facilities. Public agencies empowered to form such Zones include qualified special districts such as county service areas, community services districts, utility districts, sanitation districts, water districts, etc., as well as cities. The Zone formed under the Health and Safety Code is the area defined for operation and maintenance of onsite wastewater systems by the public agency. In 2007 the County of Marin formed the Marshall Onsite Wastewater Disposal Zone to serve as the governing entity for the Marshall Community Wastewater System.

The main advantages of County-dependent districts include: (1) availability of county resources and associated economies of scale; (2) financial strength and leverage for bonding and contracting. The key disadvantages of County-administered districts include: (1) reduced local control of the decision-making process; and (2) reduced ability to influence fiscal matters, e.g., through voluntary/community service or other cost reduction measures (e.g., County overhead, travel time and costs).

## **LAFCO**

The Local Agency Formation Commission (LAFCO) was created by the Legislature in 1963 to discourage urban sprawl and encourage the orderly formation and development of local government agencies. There is a LAFCO in each county in California except the City and County of San Francisco. LAFCO is a seven-member Commission comprised of two city council members (chosen by the Council of Mayors), two county supervisor members (chosen by the Board of Supervisors), two special district members (chosen by Independent Special District election), and one public member (chosen by the members of the Commission).

LAFCO has four major functions under State law:

- 1) To review and approve or disapprove proposals for changes in the boundaries or organization of cities and special districts in the county (including annexations to or detachments from cities and districts, incorporations of cities, formations of districts, and the dissolution, consolidation or merger of special districts), applications for activation of special district latent powers, and applications to provide service outside of a city or district boundary;
- 2) To establish and periodically update the sphere of influence or planned service area boundary for each city and special district;
- 3) To initiate and assist in studies of existing local government agencies with the goal of improving the efficiency and reducing the costs of providing urban services; and



- 4) To provide assistance to other governmental agencies and the public concerning changes in local government organization and boundaries.

With regard to the formation of County Service Areas, the Marin LAFCO implements the following policy:

*“County Service Area (CSA) Policy*

*A County Service Area may be formed when unincorporated areas that are located outside municipal sphere-of-influence boundaries desire extended urban-type services including police and fire protection from the County of Marin.*

*Unincorporated lands located within a municipal sphere-of-influence boundary should not be eligible to receive extended urban-type services from the county in the form of a County Service Area except when (a) evaluation on a case-by-case basis justifies creation and (b) the affected city, by letter, expresses approval of such action. (Originally Adopted: July 13, 1977; Revised: January 13, 1983)”*

The Woodacre-San Geronimo area does not fall within the sphere-of-influence boundary of any municipality. LAFCO policy concerning the formation of County Service Areas would appear to permit the establishment of a CSA for the provision of wastewater collection and treatment services for the study area.

Appendix K

---

# Woodacre Creek and San Geronimo Creek Microbial Source Tracking

# Woodacre Creek and San Geronimo Creek Microbial Source Tracking - Winter 2016 to Summer 2017

## Results

January 2018

Water samples were collected in collaboration with the Marin County Environmental Health Services, Marin Municipal Water District, Tomales Bay Watershed Council, the Woodacre/San Geronimo Wastewater Group, and the San Geronimo Valley Planning Group. Funding was provided by the San Francisco Bay Area Regional Water Quality Control Board. Study design was prepared by the County and Water Board staffs. Lab analysis was performed by Cel Analytical.

### Sample Sites

Water samples were collected from the following sites:

- Woodacre Creek just above the confluence with San Geronimo Creek (SWAMP 210LAG300)
- San Geronimo Creek just above confluence with Woodacre Creek (SWAMP 201LAG350)
- San Geronimo Creek under the Meadow Way Bridge (SWAMP 201LAG260)

### Sample Events

Grab samples were collected from each of the above sites during the following conditions.

1. **Winter season – December 16, 2016:** Nearly three inches of rain fell within 48 hours prior to sampling. The creek level was extremely high from recent storm. The reference stream (see note below) flow was approximately 400 ft<sup>3</sup>/sec.
2. **Winter Season – February 15, 2017:** Although there was no rain within four days of collecting samples, 6.6 inches of rain fell during the previous two weeks. The reference stream flow was approximately 165 ft<sup>3</sup>/sec
3. **Spring – May 10, 2017:** There was no reported rain within 2 weeks of sampling, when there was 0.125 inches of rain. The reference stream flow was approximately 12.4 ft<sup>3</sup>/sec.
4. **Summer - July 20, 2017:** There was no reported rainfall in the preceding month. There was only a small flow from San Geronimo Creek above the confluence with Woodacre Creek. The reference stream flow was 8.5 ft<sup>3</sup>/sec.

**Rainfall:** The nearest rainfall measurements were from Point Reyes Station, approximately 15 miles west of the project area. The accumulated rainfall from Oct 1, 2016 was 45.6 inches. The accumulated rainfall from Kentfield, approximately 15 miles to the east was 82.9 inches.

**Stream Flow:** The nearest recorded stream flows were from Samuel P. Taylor Park and is provided for reference only.

Field duplicates were collected at Woodacre Creek during the first, third, and fourth sampling event, and analyzed for all markers. A fourth field duplicate was taken at the upstream site on San Geronimo Creek during the second event, and analyzed for all markers.

Laboratory duplicate were run for all markers at the first and fourth sampling event at the upstream site on San Geronimo Creek, and at the third sampling event at Woodacre Creek. Results of the field and lab duplicates were consistent with the primary analysis for all markers.

### Sampling Parameters

Microbial Source Tracking was used to detect the presence of host-specific *Bacteroides* bacteria from different host sources within the Woodacre/San Geronimo Creek watershed. Given the characteristics of the watershed, analysis was performed for universal, human, horse, ruminant, and dog *Bacteroides* markers. Marker analysis was conducted using quantitative polymerase chain reaction (qPCR). Each grab sample was also analyzed for *E. coli*.

### Limits of Detection

Lab results for bacteroidales qPCR are presented with the following Quality Control (QC) terminology and qualifiers:

- LOD**      Limit of Detection. This is the lowest point on the standard curve.<sup>1</sup>
- LLOQ**     Lower Limit of Quantification. This is a lab reporting limit.
- DNQ**      Detected but Not Quantifiable. This qualifier is used for signals between LOD and LLOQ.
- DBLOD**    Detected Below Limit of Detection. This qualifier is used for signals detected below LOD.
- ND**        Not Detected (no detectable signal for the sample). The value associated with ND is zero.

### Results

There are no standard threshold levels for interpreting MST results. One way to analyze the results is to consider a marker to be positive when the result is above the Limit of Detection. Looking at the results this way shows strong hits for the human marker in Woodacre Creek (100%), San Geronimo Creek at Meadow Way (75%), and San Geronimo Creek above Woodacre Creek (50%). Positive results were also found for horse (25%, 50%, and 25% respectively), ruminant (0%, 25%, and 25%), and dog (25%, 25%, and 0%.) These results are presented in Tables 1 and 2.

However, given the sample size and the inherent nature of the analysis, results can also be interpreted more on trends and a presence from particular sources than on quantitative results alone. To consider results in this way, any lab signal greater than zero (ND) can be considered a positive hit for a marker; this includes results that are DBLOD. Looking at all sample sites this way indicates 75-100% positive for human markers, 50-75% for horse, 25-100% for ruminant, and 25-50% for dog. Table 3 summarizes results in this way.

Human fecal waste was present in Woodacre Creek and the Meadow Way/San Geronimo Creek sites during all four events. The highest levels were during the rainy season, particularly after a heavy rain.

---

<sup>1</sup> A standard curve is generated from analyses of serial dilutions of control DNA using the Bacteroidales species-specific primers and probe assay. LOD is the lowest point on the standard curve reproducibly detected by the lab.

The human marker (HF183)<sup>1</sup> was detected at all of the first three events on upstream San Geronimo Creek, except in the summer when there was little flow.

Horse waste was detected at each station during two to three events, but levels were higher in the spring and summer during lower flows. No horse marker was detected at any station during the first wet season sample. During the second wet season event, horse marker (HoF597)<sup>2</sup> was present at a low level. Horse markers are present at all three sites during the summer low flow. The highest strength of horse marker was in the spring at the Meadow Way/San Geronimo Creek site.

Low levels of ruminant (cattle and deer) were detected at all four events at Meadow Way/San Geronimo Creek. Ruminant were detected in the summer only in Woodacre Creek at a low level. At the upstream San Geronimo Creek site, the ruminant marker (Rum2Bac)<sup>2</sup> was detected during the first, second, and fourth event at slightly higher levels than the other stations; this is consistent with the nature of cattle grazing in this portion of the watershed. However, it is noted that the ruminant marker Rum2Bac may not be appropriate for this watershed. Ruminant markers may perform differently in different regions based on variations in the animal populations and the regional husbandry practices such as the animal subtypes, their diet, antibiotic administration, etc. At this time, the lab is working on a better marker for ruminants and may be able to retest some of the collected samples.

Dog waste was detected at least once at each station, but only during the wet season samples in December and February. The highest level of dog marker (DogBact)<sup>2</sup> was in Woodacre Creek after the large December storm.

*E. coli* results did not appear to correlate with the presence or strength of human marker.

The TMDL for Tomales Bay calls for no discharge of human waste into tributaries of Lagunitas Creek. The results of this study underscore the presence of human fecal waste in Woodacre and San Geronimo Creeks. While there is also horse, ruminant, and dog waste, the presence of human waste is the most consistent; this is particularly troubling since it indicates the potential presence of human pathogens posing a threat to public health.

---

<sup>1</sup> Improved HF183 Quantitative Real-Time PCR Assay for Characterization of Human Fecal Pollution in Ambient Surface Water Samples: May 2014 Hyatt C. Green, Richard A. Haugland, Manju Varma, Hana T. Millen, Mark A. Borchardt, Katharine G. Field, William A. Walters, R. Knight, Mano Sivaganesan, Catherine A. Kelty, Orin C. Shanks - Applied and Environmental Microbiology p. 3086–3094 Volume 80 Number 10.

<sup>2</sup> The California Microbial Source Identification Manual: A Tiered Approach to Identifying Fecal Pollution Sources to Beaches: December 2013- John F. Griffith, Blythe A. Layton, Alexandria B. Boehm, Patricia A. Holden, Jennifer A. Jay, Charles Hagedo, Charles D. McGee and Stephen B. Weisberg- Southern California Coastal Research Project Technical Report 804- Appendices.

**TABLE 1**  
**Woodacre/San Geronimo Creek**  
**Microbial Source Tracking**

Sponsored by SFRWQCB  
 Lab Analysis: Cel Analytical

Marker	Woodacre Creek above Confluence with San Geronimo Creek				San Geronimo Creek above Confluence with Woodacre Creek				San Geronimo Creek under Meadow Way			
	12/16/16	2/15/17	5/22/17	7/20/17	12/16/16	2/15/17	5/22/17	7/20/17	12/16/16	2/15/17	5/22/2017	7/20/2017
Human	Positive	Positive	Positive	Positive	Positive	Positive	Detected	No Detect	Positive	Positive	Detected	Positive
Horse	No Detect	Detected	No Detect	Positive	No Detect	Detected	Detected	Positive	No Detect	Detected	Positive	Positive
Ruminant	No Detect	No Detect	No Detect	Detected	Positive	Positive	No Detect	Detected	Detected	Detected	Detected	Detected
Dog	Positive	No Detect	No Detect	No Detect	No Detect	Detected	No Detect	No Detect	Detected	Positive	No Detect	No Detect

Positive	Results above the Limit of Detection (LOD)
Detected	Results Detected Below Level of Detection (DBLOD) or Detected but Not Quantifiable (DNQ). Non-zero signals below LOD
No Detect	Not Detected, no detectable amplification for the sample

**TABLE 2**  
**Woodacre/San Geronimo Creek**  
**Microbial Source Tracking Summary Results**

December 16, 2016

February 15, 2017

May 22, 2017

July 20, 2017

Marker	Woodacre Creek above Confluence with San Geronimo Creek (201LAG300)		San Geronimo Creek above Confluence with Woodacre Creek (201LAG350)		San Geronimo Creek under Meadow Way (201LAG260)	
	Positives	Detected	Positives	Detected	Positives	Detected
Human	100%		50%	25%	75%	25%
Horse	25%	25%	25%	50%	50%	25%
Ruminant		25%	25%	25%		100%
Dog	25%			25%	25%	25%

Positive	Results above the Limit of Detection (LOD)
Detected	Results Detected Below Level of Detection (DBLOD) or Detected but Not Quantifiable (DNQ).
No Detect	Not detected; no detectable amplification for the sample

**TABLE 3**  
**Woodacre/San Geronimo Creek**  
**Microbial Source Tracking**

December 16, 2016

February 15, 2017

May 22, 2017

July 20, 2017

This table presents positives as any signal greater than zero; this includes results Detected Below Level of Detection and Detected but Not Quantifiable.

	Woodacre Creek above Confluence with San Geronimo Creek (201LAG300)	San Geronimo Creek above Confluence with Woodacre Creek (201LAG350)	San Geronimo Creek under Meadow Way (201LAG260)
Marker	Percent positives	Percent positives	Percent positives
Human	100%	75%	100%
Horse	50%	75%	75%
Ruminant	25%	75%	100%
Dog	25%	25%	50%



## Concurrent Microbial Source Tracking Analysis using PhyloChip

Duplicate water samples were also collected and analyzed by Lawrence Berkeley Laboratory using PhyloChip analysis. This collaborative effort was funded by the San Geronimo Valley Planning Group.

Principal investigator Dr. Eric Dubinsky summarized these results: *“PhyloChip analysis of the San Geronimo Creek samples found strong fecal signals from human sources in five samples, ruminant in one sample and dog in one sample. Marginal fecal signal from human was detected in six samples, ruminant in two samples, horse in two samples and bird in two samples. Fecal signals were more frequently detected in wet season months (December and February), with the notable exceptions of a strong human signal in Montezuma Creek (site 10) in May and dog in an unnamed tributary to Woodacre Creek at 55 Park Rd (site 8) in July.”* -November 28, 2017

The comparative results of the two separate methods is presented in the following table.

**Woodacre/San Geronimo Creek  
Microbial Source Tracking and PhyloChip**

Sponsored by SFRWQCB

MST Lab Analysis: Cel Analytical

PhyloChip Analysis: Lawrence Berkeley Laboratory/UC Berkeley

Marker	Woodacre Creek above Confluence with San Geronimo Creek (LBL Station 2)				San Geronimo Creek above Confluence with Woodacre Creek (LBL Station 3)				San Geronimo Creek under Meadow Way (LBL Station 1)			
	12/16/16	2/15/17	5/22/17	7/20/17	12/16/16	2/15/17	5/22/17	7/20/17	12/16/16	2/15/17	5/22/2017	7/20/2017
<i>E. Coli</i>	816	161	214	66	2420	131	127	12	921	150	461	56
Human MST	541	136	8 DNQ	39	85	57	2 DBLOD	0	438	14	3 DBLOD	22
Human MST	Positive	Positive	Positive	Positive	Positive	Positive	Detected	No Detect	Positive	Positive	Detected	Positive
Phylochip	0.38	0.22	0.03	0.07	0.20	0.05	0.01	0.03	0.28	0.15	0.01	0.00

Horse MST	No Detect	Detected	No Detect	Positive	No Detect	Detected	Detected	Positive	No Detect	Detected	Positive	Positive
Phylochip	0.11	0.04	0.02	0.04	0.11	0.05	0.00	0.01	0.09	0.04	0.01	0.01
Ruminant MST	No Detect	No Detect	No Detect	Detected	Positive	Positive	No Detect	Detected	Detected	Detected	Detected	Detected
Phylochip	0.06	0.03	0.02	0.04	0.22	0.08	0.01	0.02	0.15	0.07	0.01	0.01
Dog MST	Positive	No Detect	No Detect	No Detect	No Detect	Detected	No Detect	No Detect	Detected	Positive	No Detect	No Detect
Phylochip	0.04	0.02	0.03	0.05	0.04	0.03	0.01	0.02	0.04	0.02	0.01	0.01

	Exceeds <i>E. coli</i> standard
Positive	Results above the MST Limit of Detection (LOD) and PhyloChip 0.20 and above
Positive	PhyloChip results between 0.1 and 0.2 indicates marginal source
Detected	MST Results Detected Below Level of Detection (DBLOD) or Detected but Not Quantifiable (DNQ). Non-zero signals below LOD
No Detect	For MST, no detectable amplification for the sample; for PhyloChip, result less than 0.1

Human Marker LOD = 6 gc/mL

Humna Marker LLOQ = 12 gc/mL

0 = Non detect

DBLOD = Detected below level of detection

DNQ = Detected but not quantifiable